

INA233 High-Side or Low-Side Measurement, Bidirectional Current and Power Monitor With I²C-, SMBus-, and PMBus-Compatible Interface

1 Features

- Senses Bus Voltages From 0 V to 36 V
- High-Side or Low-Side Sensing
- Reports Current, Voltage, and Power
- Integrated Power Accumulator for Energy and Average Power Monitoring
- High Accuracy:
 - 0.1% Gain Error (Max)
 - 10- μ V Offset (Max)
- Configurable Averaging Options
- Independent Alert Limits for Current, Bus Voltage, and Power
- 1.8-V Compliant I²C, SMBus, PMBus Interface
- 16 Programmable Addresses
- Operates From a 2.7-V to 5.5-V Power Supply
- 10-Pin, DGS (VSSOP) Package

2 Applications

- Servers
- Telecom Infrastructure
- High-Performance Computing
- Power Metering
- Battery Chargers
- Power Supply
- Test Equipment

3 Description

The INA233 device is a current, voltage, and power monitor with an I²C-, SMBus-, and PMBus-compatible interface that is compliant with digital bus voltages from 1.8 V to 5.0 V. The device monitors and reports values for current, voltage, and power. The integrated power accumulator can be used for energy or average power calculations. Programmable calibration value, conversion times, and averaging when combined with an internal multiplier enable direct readouts of current in amperes and power in watts.

The INA233 senses current on common-mode bus voltages that can vary from 0 V to 36 V, independent of the supply voltage. The device operates from a single 2.7-V to 5.5-V supply, drawing a typical supply current of 310 μ A in normal operation. The device can be placed in a low-power standby mode where the typical operating current is only 2 μ A. The device is specified over the operating temperature range between -40°C and $+125^{\circ}\text{C}$ and features up to 16 programmable addresses.

Device Information⁽¹⁾

PART NUMBER	PACKAGE	BODY SIZE (NOM)
INA233	VSSOP (10)	3.00 mm x 3.00 mm

(1) For all available packages, see the orderable addendum at the end of the datasheet.

High-Side or Low-Side Sensing Application

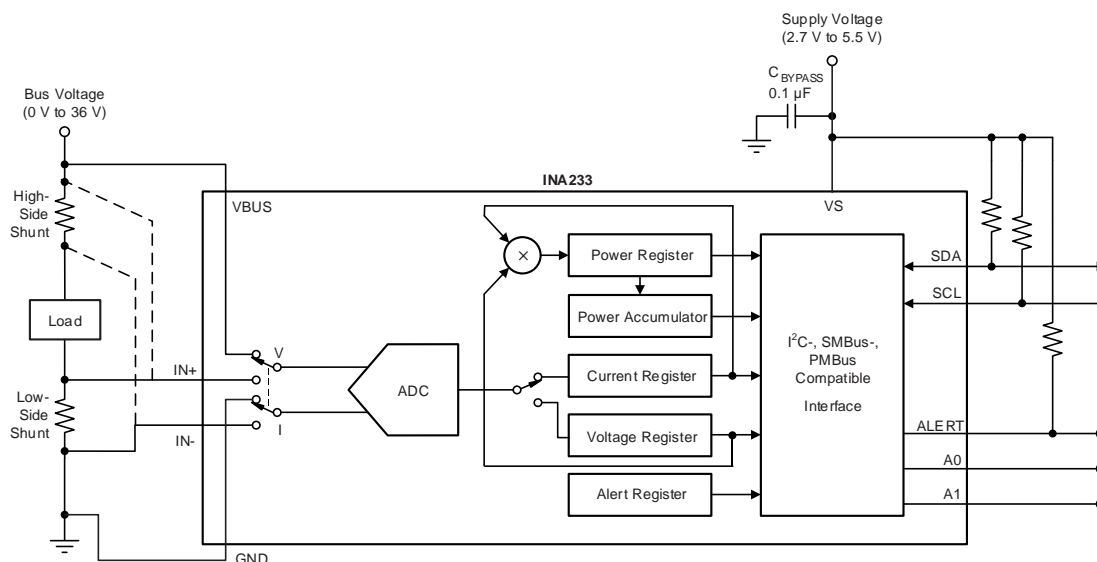

Copyright © 2017, Texas Instruments Incorporated



Table of Contents

1 Features	1	7.6 Register Maps	23
2 Applications	1	8 Application and Implementation	41
3 Description	1	8.1 Application Information.....	41
4 Revision History	2	8.2 Typical Application	41
5 Pin Configuration and Functions	3	9 Power Supply Recommendations	44
6 Specifications	4	10 Layout	44
6.1 Absolute Maximum Ratings	4	10.1 Layout Guidelines	44
6.2 ESD Ratings.....	4	10.2 Layout Example	44
6.3 Recommended Operating Conditions	4	11 Device and Documentation Support	45
6.4 Thermal Information	4	11.1 Device Support	45
6.5 Electrical Characteristics.....	5	11.2 Documentation Support	45
6.6 Typical Characteristics	7	11.3 Receiving Notification of Documentation Updates	45
7 Detailed Description	11	11.4 Community Resources.....	45
7.1 Overview	11	11.5 Trademarks	45
7.2 Functional Block Diagram	11	11.6 Electrostatic Discharge Caution.....	45
7.3 Feature Description.....	11	11.7 Glossary	45
7.4 Device Functional Modes.....	13	12 Mechanical, Packaging, and Orderable	45
7.5 Programming.....	15	Information	45

4 Revision History

DATE	REVISION	NOTES
April 2017	*	Initial release.

5 Pin Configuration and Functions

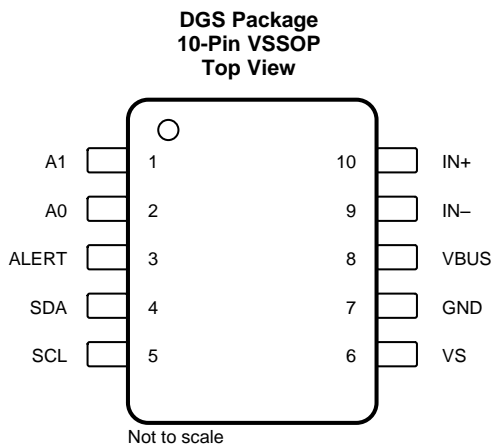

Pin Functions

PIN		I/O	DESCRIPTION
NAME	NO.		
A0	2	Digital input	Address pin. Connect to GND, SCL, SDA, or VS. Table 3 lists the pin settings and corresponding addresses.
A1	1	Digital input	Address pin. Connect to GND, SCL, SDA, or VS. Table 3 lists the pin settings and corresponding addresses.
ALERT	3	Digital output	PMBus-compatible multifunctional alert, open-drain output. This pin alerts on independent settings for overcurrent, under- and overvoltage, and overpower conditions.
GND	7	Analog	Ground
IN-	9	Analog input	Connect to the load side of the shunt resistor
IN+	10	Analog input	Connect to the supply side of the shunt resistor
SCL	5	Digital input	Serial bus clock line, open-drain input
SDA	4	Digital I/O	Serial bus data line, open-drain input/output
VBUS	8	Analog input	Bus voltage input
VS	6	Analog	Power supply, 2.7 V to 5.5 V

6 Specifications

6.1 Absolute Maximum Ratings

over operating free-air temperature range (unless otherwise noted)⁽¹⁾

		MIN	MAX	UNIT	
V _{VS}	Supply voltage		6	V	
	Analog Inputs, IN+, IN–	Differential (V _{IN+} – V _{IN–}) ⁽²⁾	–40	40	V
		Common-mode	–0.3	40	
V _{VBUS}	VBUS pin voltage	–0.3	40	V	
V _{SDA}	SDA, SCL pin voltages	GND – 0.3	6	V	
V _A	A0, A1 pin voltages	GND – 0.3	6	V	
I _{IN}	Input current into any pin		5	mA	
I _{OUT}	Open-drain digital output current		10	mA	
T _J	Junction temperature		150	°C	
T _{stg}	Storage temperature	–65	150	°C	

- (1) Stresses beyond those listed under *Absolute Maximum Ratings* may cause permanent damage to the device. These are stress ratings only, which do not imply functional operation of the device at these or any other conditions beyond those indicated under *Recommended Operating Conditions*. Exposure to absolute-maximum-rated conditions for extended periods may affect device reliability.
- (2) IN+ and IN– can have a differential voltage between –40 V and 40 V. However, the voltage at these pins must not exceed the range of –0.3 V to 40 V.

6.2 ESD Ratings

		VALUE	UNIT
V _(ESD)	Electrostatic discharge	Human-body model (HBM), per ANSI/ESDA/JEDEC JS-001 ⁽¹⁾	±2500
		Charged-device model (CDM), per JEDEC specification JESD22-C101 ⁽²⁾	±1000

- (1) JEDEC document JEP155 states that 500-V HBM allows safe manufacturing with a standard ESD control process.
- (2) JEDEC document JEP157 states that 250-V CDM allows safe manufacturing with a standard ESD control process.

6.3 Recommended Operating Conditions

over operating free-air temperature range (unless otherwise noted)

		MIN	NOM	MAX	UNIT
V _{CM}	Common-mode input voltage	0		36	V
V _{VS}	Operating supply voltage	2.7		5.5	V
T _A	Operating free-air temperature	–40		125	°C

6.4 Thermal Information

THERMAL METRIC ⁽¹⁾		INA233	UNIT
		DGS (VSSOP)	
		10 PINS	
R _{θJA}	Junction-to-ambient thermal resistance	171.4	°C/W
R _{θJC(top)}	Junction-to-case (top) thermal resistance	42.9	°C/W
R _{θJB}	Junction-to-board thermal resistance	91.8	°C/W
Ψ _{JT}	Junction-to-top characterization parameter	1.5	°C/W
Ψ _{JB}	Junction-to-board characterization parameter	90.2	°C/W
R _{θJC(bot)}	Junction-to-case (bottom) thermal resistance	n/a	°C/W

- (1) For more information about traditional and new thermal metrics, see the [Semiconductor and IC Package Thermal Metrics](#) application report.

6.5 Electrical Characteristics

at $T_A = 25^\circ\text{C}$, $V_{VS} = 3.3\text{ V}$, $V_{IN+} = 12\text{ V}$, $V_{SENSE} = (V_{IN+} - V_{IN-}) = 0\text{ mV}$, and $V_{VBUS} = 12\text{ V}$ (unless otherwise noted)

PARAMETER	TEST CONDITIONS	MIN	TYP	MAX	UNIT	
INPUT						
	Shunt voltage input range	-81.92		81.9175	mV	
	Bus voltage input range ⁽¹⁾	0		36	V	
CMRR	Common-mode rejection ratio	0 V ≤ V_{IN+} ≤ 36 V		126	140	dB
V_{OS}	Offset voltage, RTI ⁽²⁾	Shunt voltage		±2.5	±10	μV
		Bus voltage		±1.25	±7.5	mV
V_{OS}	V_{OS} (RTI ⁽²⁾) vs temperature	Shunt voltage, $-40^\circ\text{C} \leq T_A \leq +125^\circ\text{C}$		0.02	0.1	μV/°C
		Bus voltage, $-40^\circ\text{C} \leq T_A \leq +125^\circ\text{C}$		10	40	
PSRR	Power-supply rejection ratio (RTI ⁽²⁾)	Shunt voltage, $2.7\text{ V} \leq V_S \leq 5.5\text{ V}$		1		μV/V
		Bus voltage		0.5		mV/V
I_B	Input bias current (I_{IN+} , I_{IN-} pins)		8		μA	
	VBUS input impedance		830		kΩ	
	Input leakage ⁽³⁾	(IN+) + (IN-), power-down mode	0.1	0.5	μA	
DC ACCURACY						
	ADC native resolution		16		Bits	
	1-LSB step size	Shunt voltage		2.5		μV
		Bus voltage		1.25		mV
	Shunt voltage gain error		0.02%	0.1%		
	Shunt voltage gain error vs temperature	$-40^\circ\text{C} \leq T_A \leq +125^\circ\text{C}$	5	25	ppm/°C	
	Bus voltage gain error		0.02%	0.1%		
	Bus voltage gain error vs temperature	$-40^\circ\text{C} \leq T_A \leq +125^\circ\text{C}$	10	50	ppm/°C	
	Power gain error	$V_{BUS} = 12\text{ V}$, $V_{IN+} - V_{IN-} = -80\text{ mV}$ to 80 mV	0.05%	0.2%		
	Power gain error vs temperature	$-40^\circ\text{C} \leq T_A \leq +125^\circ\text{C}$	10	50	ppm/°C	
DNL	Differential nonlinearity		±0.1		LSB	
t_{CT}	ADC conversion time	CT bit = 000		140	154	μs
		CT bit = 001		204	224	
		CT bit = 010		332	365	
		CT bit = 011		588	646	
		CT bit = 100		1.1	1.21	ms
		CT bit = 101		2.116	2.328	
		CT bit = 110		4.156	4.572	
		CT bit = 111		8.244	9.068	
SMBus						
	SMBus timeout ⁽⁴⁾		28	35	ms	

(1) Although the input range is 36 V, the full-scale range of the ADC scaling is 40.96 V; see the [High-Accuracy Analog-to-Digital Converter \(ADC\)](#) section. Do not apply more than 36 V.

(2) RTI = Referred-to-input.

(3) Input leakage is positive (current flowing into the pin) for the conditions shown at the top of this table. Negative leakage currents can occur under different input conditions.

(4) SMBus timeout in the INA233 resets the interface whenever SCL is low for more than 28 ms.

Electrical Characteristics (continued)

 at $T_A = 25^\circ\text{C}$, $V_{VS} = 3.3\text{ V}$, $V_{IN+} = 12\text{ V}$, $V_{SENSE} = (V_{IN+} - V_{IN-}) = 0\text{ mV}$, and $V_{VBUS} = 12\text{ V}$ (unless otherwise noted)

PARAMETER	TEST CONDITIONS	MIN	TYP	MAX	UNIT
DIGITAL INPUT/OUTPUT					
Input capacitance			3		pF
Leakage input current	$0\text{ V} \leq V_{SCL} \leq V_{VS}$, $0\text{ V} \leq V_{SDA} \leq V_{VS}$, $0\text{ V} \leq V_{Alert} \leq V_{VS}$, $0\text{ V} \leq V_{A0} \leq V_{VS}$, $0\text{ V} \leq V_{A1} \leq V_{VS}$		0.5	2	μA
V_{IH}	High-level input voltage	SDA pin	1.4	6	V
V_{IL}	Low-level input voltage	SDA pin	-0.3	0.4	V
V_{OL}	Low-level output voltage	$I_{OL} = 3\text{ mA}$, SDA and ALERT pins	0	0.4	V
	Hysteresis		500		mV
POWER SUPPLY					
	Operating supply range		2.7	5.5	V
I_Q	Quiescent current		310	400	μA
	Quiescent current, power-down (shutdown) mode		2	5	μA
V_{POR}	Power-on-reset (POR) threshold voltage		2		V

6.6 Typical Characteristics

at $T_A = 25^\circ\text{C}$, $V_{VS} = 3.3\text{ V}$, $V_{IN+} = 12\text{ V}$, $V_{SENSE} = (V_{IN+} - V_{IN-}) = 0\text{ mV}$, and $V_{VBUS} = 12\text{ V}$ (unless otherwise noted)

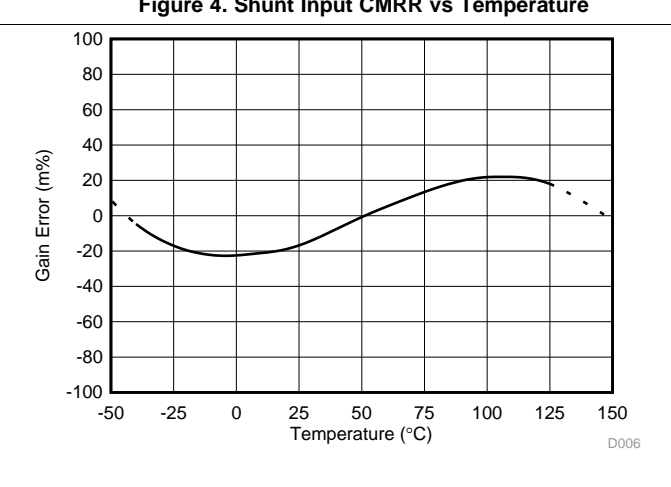
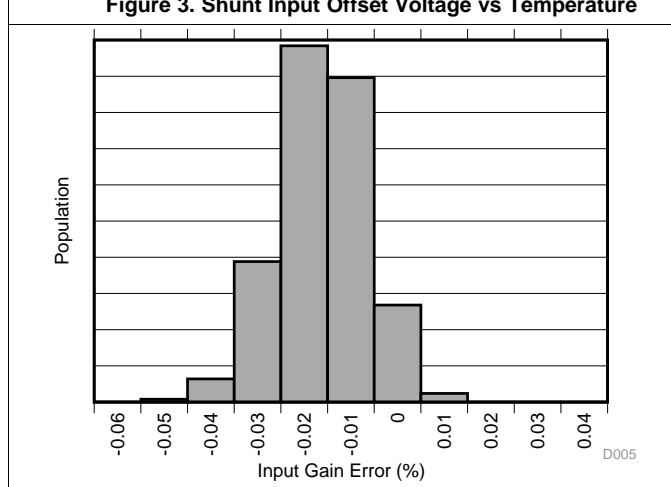
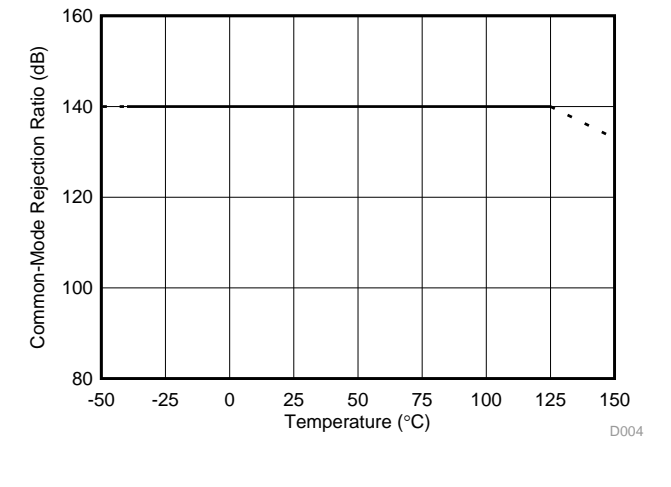
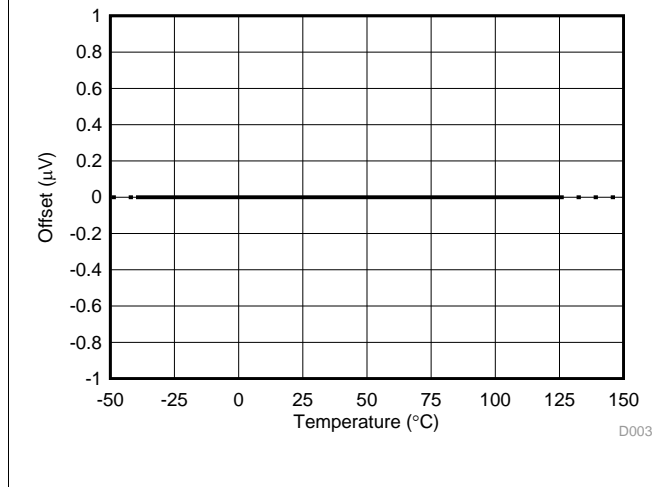
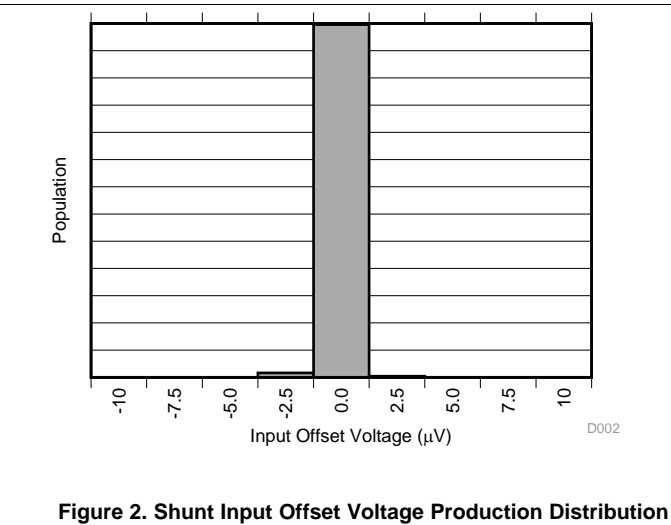
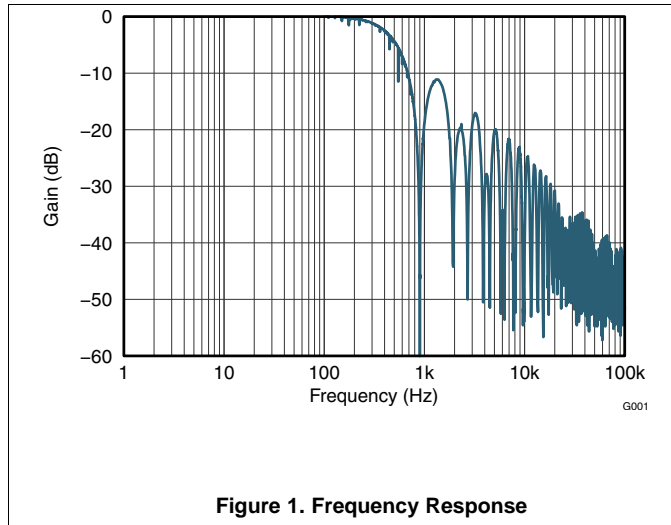

Typical Characteristics (continued)

at $T_A = 25^\circ\text{C}$, $V_{VS} = 3.3\text{ V}$, $V_{IN+} = 12\text{ V}$, $V_{SENSE} = (V_{IN+} - V_{IN-}) = 0\text{ mV}$, and $V_{VBUS} = 12\text{ V}$ (unless otherwise noted)

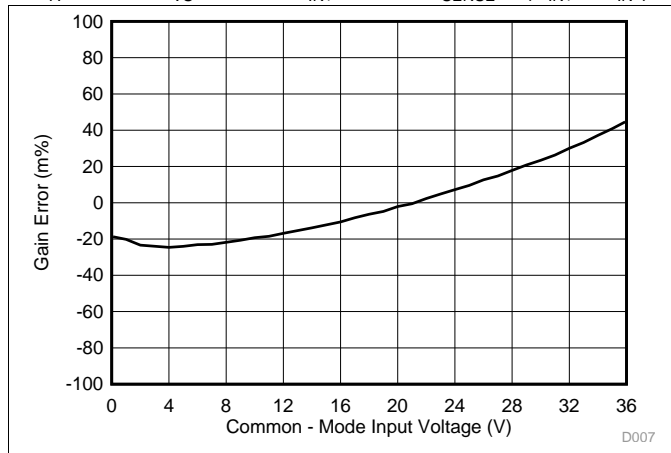

Figure 7. Shunt Input Gain Error vs Common-Mode Voltage

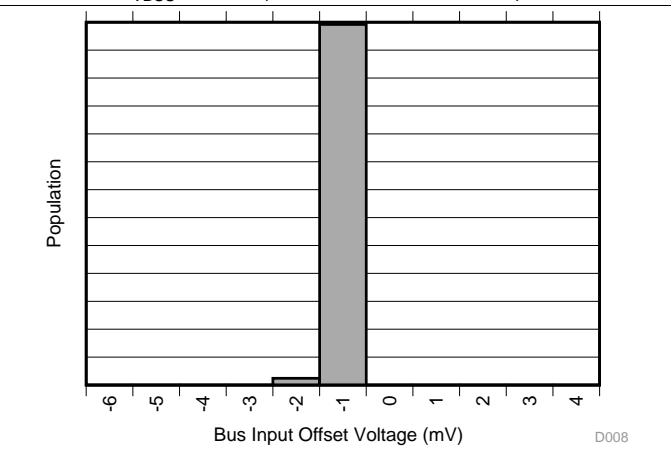

Figure 8. Bus Input Offset Voltage Production Distribution

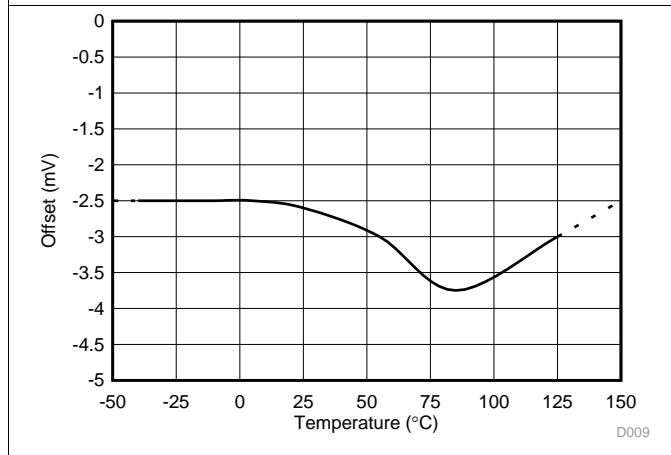

Figure 9. Bus Input Offset Voltage vs Temperature

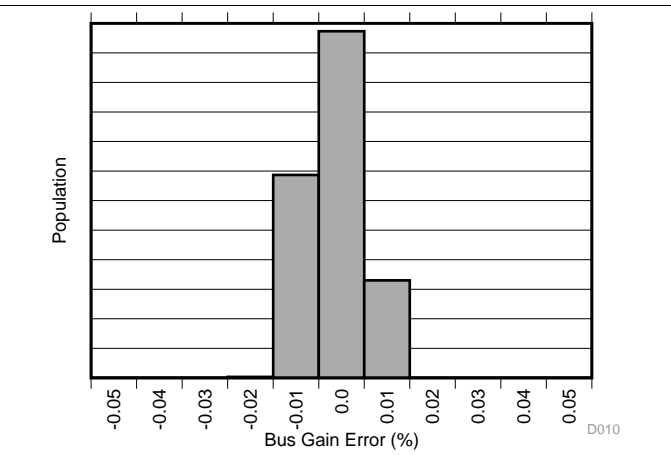

Figure 10. Bus Input Gain Error Production Distribution

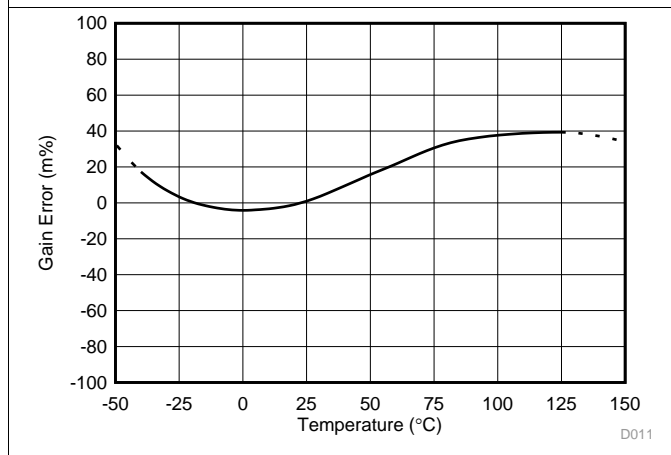

Figure 11. Bus Input Gain Error vs Temperature

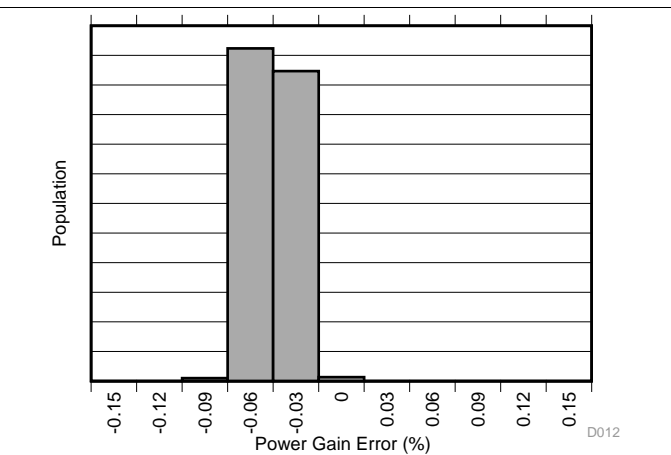

Figure 12. Power Gain Error Production Distribution

Typical Characteristics (continued)

at $T_A = 25^\circ\text{C}$, $V_{VS} = 3.3\text{ V}$, $V_{IN+} = 12\text{ V}$, $V_{SENSE} = (V_{IN+} - V_{IN-}) = 0\text{ mV}$, and $V_{VBUS} = 12\text{ V}$ (unless otherwise noted)

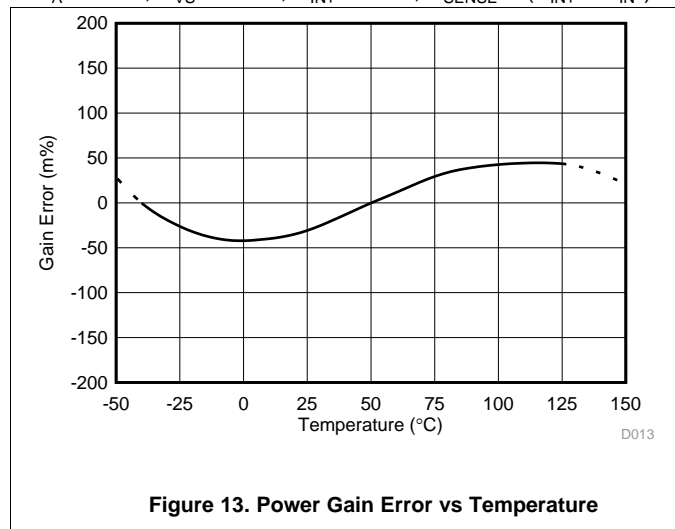

Figure 13. Power Gain Error vs Temperature

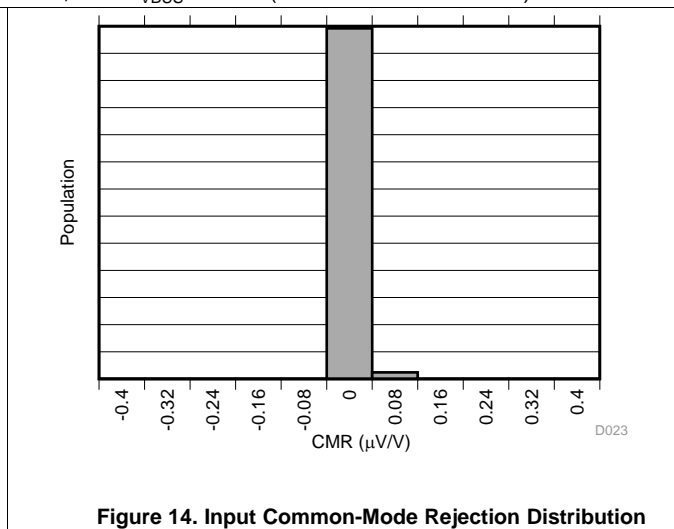

Figure 14. Input Common-Mode Rejection Distribution

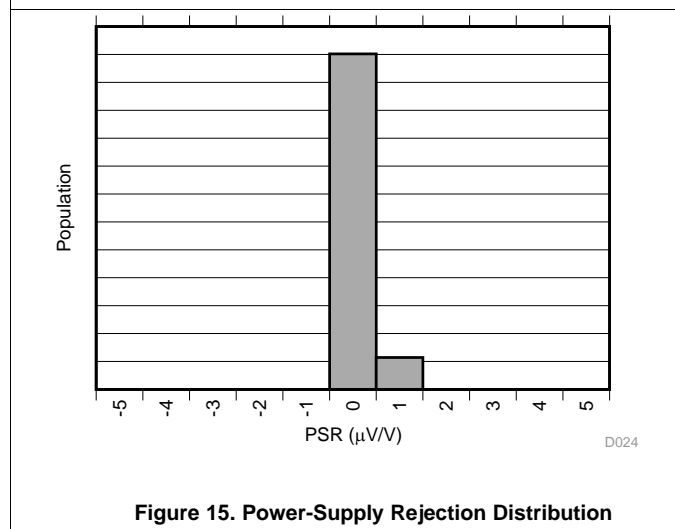

Figure 15. Power-Supply Rejection Distribution

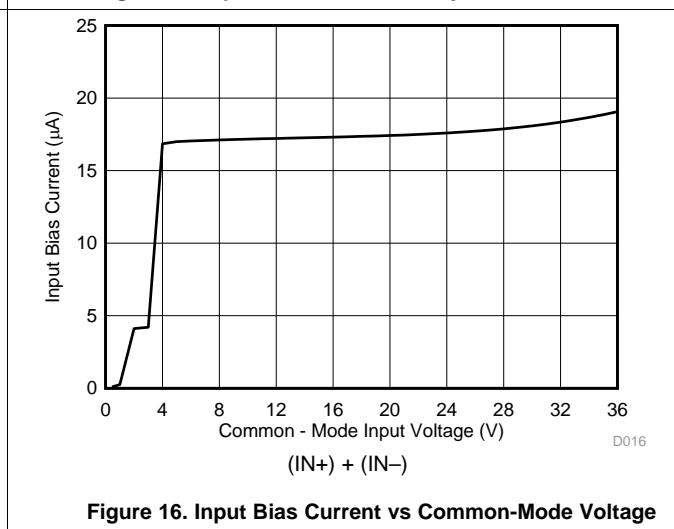

Figure 16. Input Bias Current vs Common-Mode Voltage

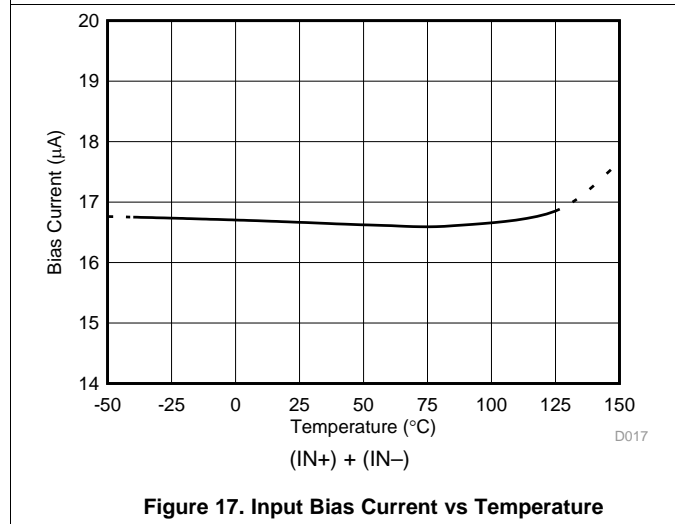

Figure 17. Input Bias Current vs Temperature

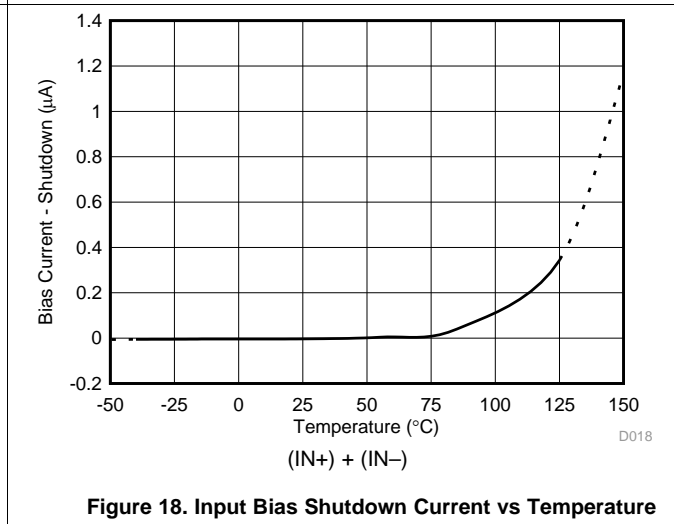
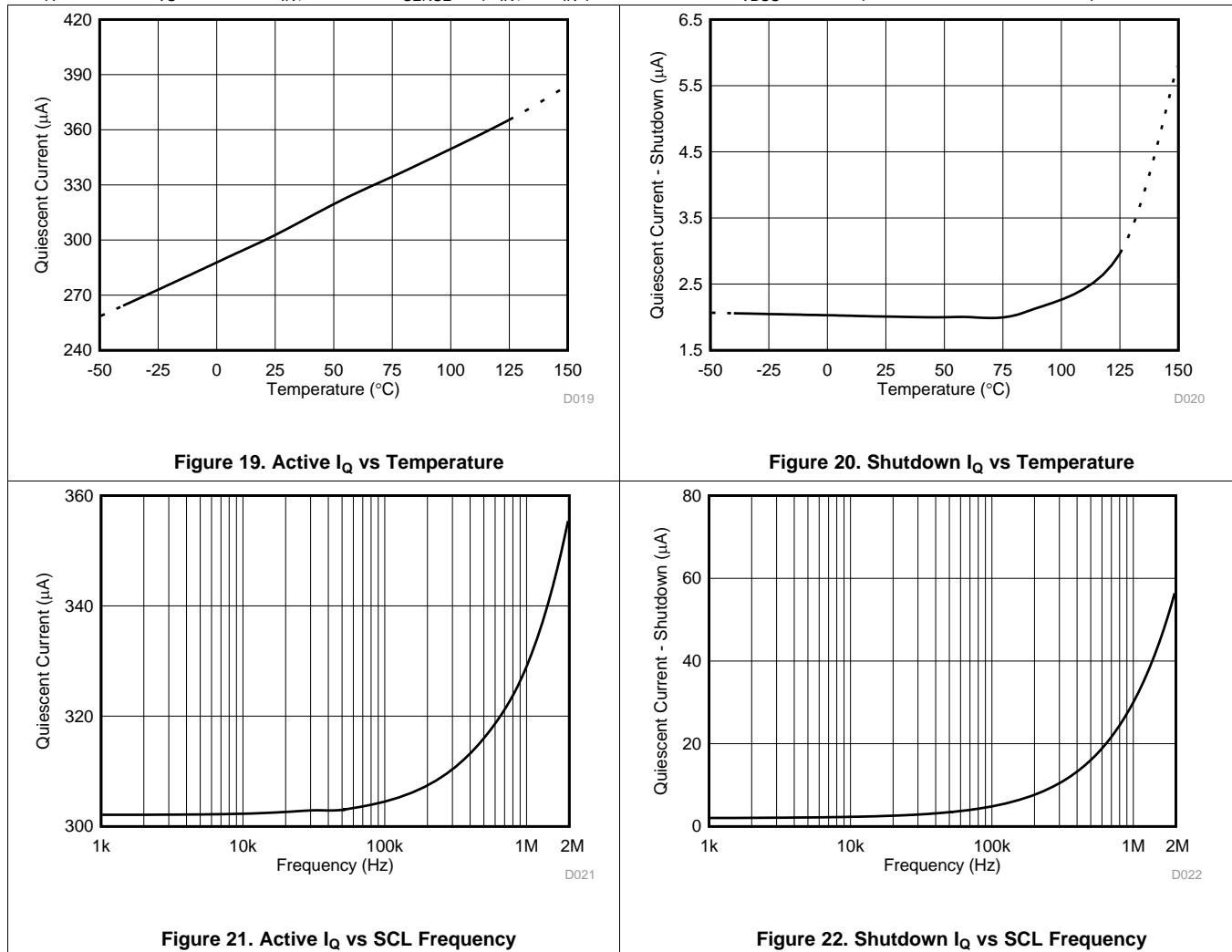

Figure 18. Input Bias Shutdown Current vs Temperature

Typical Characteristics (continued)

at $T_A = 25^\circ\text{C}$, $V_{VS} = 3.3\text{ V}$, $V_{IN+} = 12\text{ V}$, $V_{SENSE} = (V_{IN+} - V_{IN-}) = 0\text{ mV}$, and $V_{VBUS} = 12\text{ V}$ (unless otherwise noted)



7 Detailed Description

7.1 Overview

The INA233 is a digital current-sense amplifier with an I²C-, SMBus-, and PMBus-compatible interface. The device provides digital current, voltage, and power readings necessary for accurate decision-making in precisely-controlled systems. The INA233 also has a built-in power accumulator that can be used for energy or average power measurements. Programmable out-of-range limits can be set to issue alerts when the voltage, current, or power is outside the normal range of operation. The integrated analog-to-digital converter (ADC) can be set to different averaging modes and configured for continuous-versus-triggered operation. The [Register Maps](#) section provides detailed register information for the INA233.

7.2 Functional Block Diagram

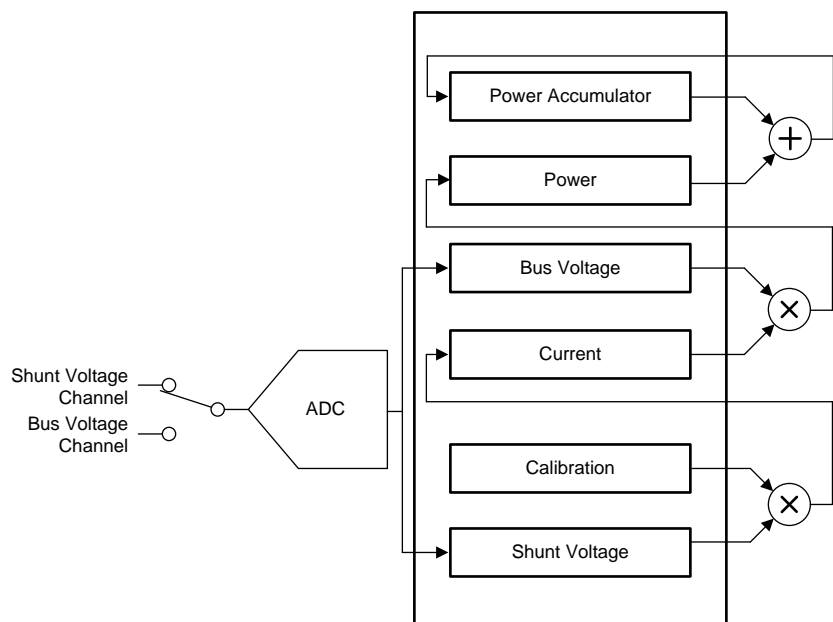

Copyright © 2017, Texas Instruments Incorporated

7.3 Feature Description

7.3.1 High-Accuracy Analog-to-Digital Convertor (ADC)

The INA233 integrates a highly accurate, 16-bit, delta-sigma ($\Delta\Sigma$) ADC. This ADC is multiplexed to process both the shunt voltage and bus voltage measurements. The shunt voltage measurement is a differential measurement of the voltage developed when the load current flows through a shunt resistor as measured at the IN+ and IN– pins. The shunt voltage measurement has a maximum offset voltage of only 10 μ V and a maximum gain error of only 0.1%. The low offset voltage of the shunt voltage measurement allows for increased accuracy at light load conditions for a given shunt resistor value. Another advantage of low offset is the ability to sense lower voltage drop across the sense resistor accurately, thus allowing for a lower-value shunt resistor. Lower-value shunt resistors reduce power loss in the current-sense circuit and help improve the power efficiency of the end application. The device can also measure the power-supply bus voltage by connecting this voltage to the VBUS pin. Internally, the voltage at VBUS is divided down to a voltage that can be measured by the ADC. The impedance of the VBUS pin to ground is approximately 830 k Ω . The differential shunt voltage is measured between the IN+ and IN– pins and the bus voltage is measured between the VBUS pin and GND.

The device takes two measurements: shunt voltage and bus voltage. The INA233 then converts these measurements to current, based on the calibration register value, and then calculates power; see the [Calibration Register and Scaling](#) section for additional information on programming the calibration register.

Feature Description (continued)

7.3.5 Multiple Fault Event Reporting

The INA233 open-drain ALERT pin can report if any of the following errors simultaneously occur:

- Overcurrent warning
- Overpower warning
- Bus overvoltage warning
- Bus undervoltage warning
- Communication faults
- ADC overflow
- Conversion ready

The warning thresholds for the current, power, and bus voltages are set with the [IOUT_OC_WARN_LIMIT](#), [PIN_OP_WARN_LIMIT](#), [VIN_UV_WARN_LIMIT](#), and [VIN_OV_WARN_LIMIT](#) standard PMBus commands. Various bus communications faults are supported as outlined in the [STATUS_CML](#) PMBus command.

The status for the conversion ready and ADC overflow bits can be monitored by the [STATUS_MFR_SPECIFIC](#) command. The conversion ready bit notifies when the device completes the previous conversion and is ready to begin a new conversion. Conversion ready can be monitored at the ALERT pin along with one of the alert functions. If an alert function and the conversion ready are both enabled to be monitored at the ALERT pin, then after the ALERT pin is asserted, the [MFR_ALERT_MASK](#) register or the PMBus status registers must be read following the alert to determine the source of the alert.

If the alert function is not used, the ALERT pin can be left floating without affecting device operation.

7.4 Device Functional Modes

7.4.1 Continuous versus Triggered Operation

The internal ADC has two operating modes, continuous and triggered, that determine how the ADC operates following shunt voltage and bus voltage conversions. When the device is in normal operating mode, the INA233 continuously converts a shunt voltage reading followed by a bus voltage reading. After the shunt voltage reading, the current value is calculated. This current value is then used to calculate the power result. These values are subsequently stored in an accumulator, and the measurement and calculation sequence repeats until the number of averages set in the [MFR_ADC_CONFIG](#) register is reached. Following every sequence, the present set of values measured and calculated are appended to previously collected values. After all averaging completes, the final values for the shunt voltage, bus voltage, current, and power are updated in the corresponding registers that can then be read.

The [MFR_ADC_CONFIG](#) command allows for selecting modes that only convert the shunt voltage or the bus voltage to further allow the monitoring function to be configured to better fit the specific application requirements. This command also allows the device to be configured in continuous-versus-triggered operation. In triggered mode, writing any of the triggered convert modes into the [MFR_ADC_CONFIG](#) register triggers a single-shot conversion. This action produces a single set of measurements; thus, to trigger another single-shot conversion, the [MFR_ADC_CONFIG](#) register must be written to a second time, even if the mode does not change.

7.4.2 Device Shutdown

In addition to the two operating modes (continuous and triggered), the internal ADC also has a power-down mode that reduces the quiescent current and turns off current into the device inputs, reducing the effect of supply drain when the device is not being used. Full recovery from power-down mode requires 40 μ s. The device registers can be written to and read from when the device is in power-down mode. The device remains in power-down mode until one of the active modes settings is selected using the [MFR_ADC_CONFIG](#) command.

7.4.3 Averaging and Conversion Time Considerations

The INA233 offers programmable conversion times (t_{CT}) for both the shunt voltage and bus voltage measurements. The conversion times for these measurements can be selected from as fast as 140 μ s to as long as 8.244 ms. The conversion time settings, along with the programmable averaging mode, allow the device to be configured to optimize the available timing requirements in a given application. For example, if a system requires that data be read every 5 ms, the device can be configured with the conversion times set to 588 μ s for both

Device Functional Modes (continued)

shunt and bus voltage measurements and the averaging mode set to 4. This configuration results in the data updating approximately every 4.7 ms. The device can also be configured with a different conversion time setting for the shunt and bus voltage measurements. This type of approach is common in applications where the bus voltage tends to be relatively stable. This situation can allow for the time focused on the bus voltage measurement to be reduced relative to the shunt voltage measurement. The shunt voltage conversion time can be set to 4.156 ms with the bus voltage conversion time set to 588 μ s and averaging mode set to 1. This configuration also results in data updating approximately every 4.7 ms.

There are trade-offs associated with the settings for conversion time and the averaging mode used. The averaging feature can significantly improve the measurement accuracy by effectively filtering the signal. This approach allows the device to reduce any noise in the measurement that may be caused by noise coupling into the signal. A greater number of averages enables the device to be more effective in reducing the noise component of the measurement.

The conversion times selected can also have an effect on the measurement accuracy. [Figure 24](#) shows multiple conversion times to illustrate the effect of noise on the measurement. In order to achieve the highest accuracy measurement possible, use a combination of the longest allowable conversion times and highest number of averages, based on the timing requirements of the system.

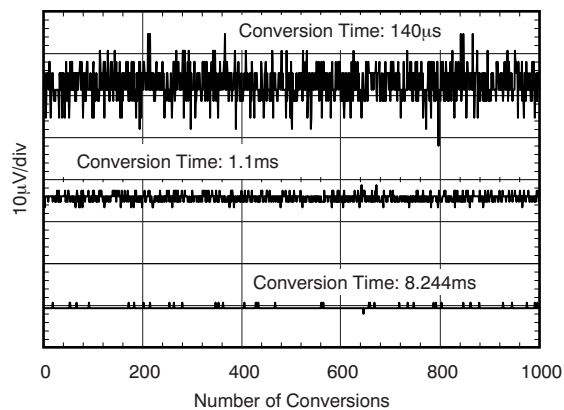

Figure 24. Noise vs Conversion Time

7.4.4 Filtering and Input Considerations

Measuring current is often noisy and such noise can be difficult to define. The INA233 offers several options for filtering by allowing the conversion times and number of averages to be selected independently in the MFR_ADC_CONFIG register. The conversion times can be set independently for the shunt voltage and bus voltage measurements to allow added flexibility when configuring the monitoring of the power-supply bus.

The internal ADC is based on a delta-sigma ($\Delta\Sigma$) front-end with a 500-kHz ($\pm 10\%$ max) sampling rate. This architecture has good inherent noise rejection; however, transients that occur at or very close to the sampling rate harmonics can cause problems. These signals are at 1 MHz and higher and can be managed by incorporating filtering at the device input. The high frequency enables the use of low-value series resistors on the filter with negligible effects on measurement accuracy. In general, filtering the device input is only necessary if there are transients at exact harmonics of the 500 kHz ($\pm 10\%$ max) sampling rate (greater than 1 MHz). Filter using the lowest possible series resistance (typically 10 Ω or less) and a ceramic capacitor. Recommended values for this capacitor are between 0.1 μ F and 1 μ F. [Figure 25](#) illustrates the device with a filter added at the input.

Device Functional Modes (continued)

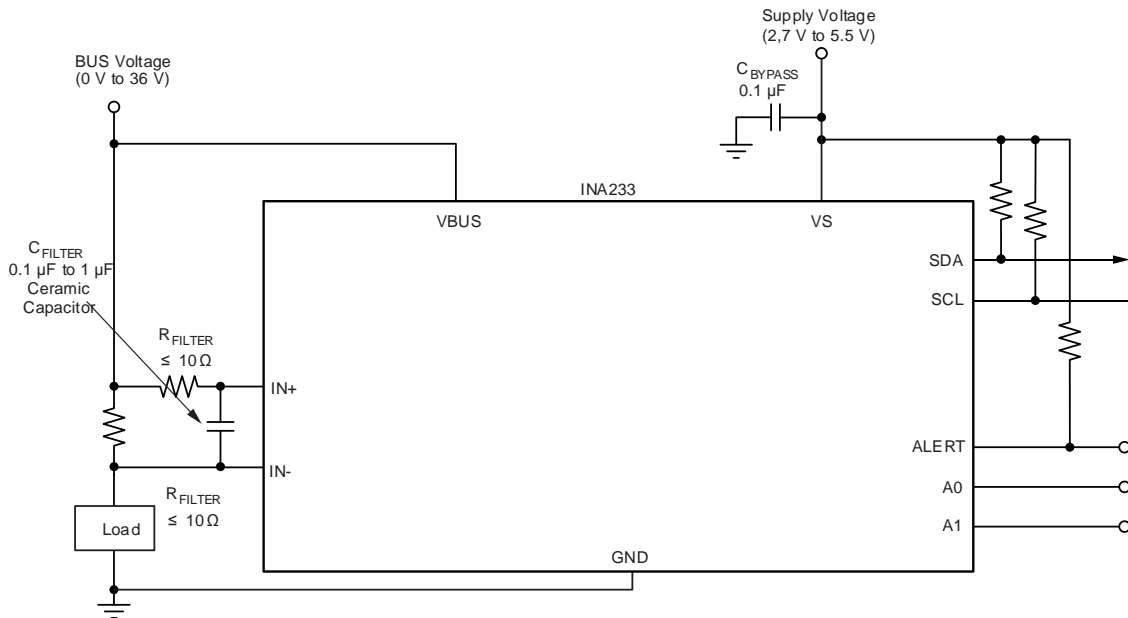

Copyright © 2016, Texas Instruments Incorporated

Figure 25. Input Filtering

Overload conditions are another consideration for the device inputs. The device inputs are specified to tolerate 40 V across the inputs. A large differential scenario can be a short to ground on the load side of the shunt. This type of event can result in full power-supply voltage across the shunt (as long the power supply or energy storage capacitors can support this voltage). Removing a short to ground can result in inductive kickbacks that can exceed the 40-V differential and common-mode rating of the device. Inductive kickback voltages are best controlled by Zener-type, transient-absorbing devices (commonly called *transzorb*s) combined with sufficient energy storage capacitance. The [Current Shunt Monitor with Transient Robustness Reference Design](#) describes a high-side, current-shunt monitor used to measure the voltage developed across a current-sensing resistor and how to better protect the current-sense device from transient overvoltage conditions.

In applications that do not have large energy storage electrolytics on one or both sides of the shunt, an input overstress condition can result from an excessive dV/dt of the voltage applied to the input. A hard physical short is the most likely cause of this event, particularly in applications with no large electrolytics present. This problem occurs because an excessive dV/dt can activate the ESD protection in the device in systems where large currents are available. Testing demonstrates that the addition of 10-Ω resistors in series with each input of the device sufficiently protects the inputs against this dV/dt failure up to the 40-V rating of the device. Selecting these resistors in the range noted has minimal effect on accuracy.

7.5 Programming

The device can be used without any programming only when reading a shunt voltage drop and bus voltage with the default power-on reset configuration and with continuous conversion of the shunt and bus voltages.

Without setting the device register with the MFR_CALIBRATION command, the device is unable to provide either a valid current or power value because these outputs are both derived using the values loaded into the calibration register. The MFR_CALIBRATION command sets the current LSB size based on the desired full-scale range and value of the shunt resistor.

7.5.1 Default Settings

The default power-up states of the registers are shown in the [Register Maps](#) section. These registers are volatile and, if programmed to a value other than the default values listed in [Table 4](#), must be reprogrammed at every device power-up. Detailed information on programming the calibration register specifically is given in the [Programming](#) section and calculated based on [Equation 1](#).

Programming (continued)

7.5.2 Calibration Register and Scaling

An important aspect of the INA233 is that the device does not necessarily measure current or power. The device measures both the differential voltage applied between the IN+ and IN– input pins and the voltage applied to the VBUS pin. By correctly setting the calibration register scaling with the MFR_CALIBRATION command, returned values are calculated in voltage, amperes, and watts by scaling the returned value by the appropriate least significant bit value (LSB) or by using the PMBus direct mode equation ([Equation 3](#)).

[Equation 1](#) is used to obtain the value for the MFR_CALIBRATION register. This equation includes the term *Current_LSB*, which is the chosen value for the LSB for the READ_IIN command. As [Equation 2](#) shows, the highest resolution for current measurements can be obtained by using the smallest allowable *Current_LSB* based on the maximum expected current. Although this value yields the highest resolution, the *Current_LSB* value is commonly selected as the nearest full number above this value to simplify the conversion of returned values for current and power to amperes and watts, respectively. The R_{SHUNT} term is the value of the external shunt used to develop the differential voltage across the input pins.

$$CAL = \frac{0.00512}{Current_LSB \cdot R_{SHUNT}}$$

where

- 0.00512 is an internal fixed value used to ensure that scaling is maintained properly (1)

$$Current_LSB = \frac{Maximum\ Expected\ Current}{2^{15}} \quad (2)$$

After programming the calibration register, the values returned by the read current, power, and energy commands update accordingly based on the corresponding shunt voltage and bus voltage measurements.

Returned values for voltage, current, and power are calculated by multiplying the appropriate LSB value by the returned value, or can be calculated with PMBus coefficients as detailed in the [Reading and Writing Telemetry Data and Warning Thresholds](#) section. The size of the Power_LSB is internally set as 25 times the selected *Current_LSB*. The voltage LSB for bus voltage (READ_VIN and READ_VOUT commands) and shunt voltage (MFR_READ_VSHUNT) are fixed at 1.25 mV/bit and 2.5 μ V/bit, respectively.

The MFR_CALIBRATION command allows the values returned by the READ_IN and READ_PIN commands to be scaled to the most useful value for a given application. For example, set the MFR_CALIBRATION register so that the largest possible number is returned by the READ_IN and READ_PIN commands at the expected full-scale point. This approach yields the highest resolution using the previously calculated minimum *Current_LSB* in [Equation 1](#). The calibration register can also be selected so that READ_IN and READ_PIN return direct decimal equivalents of the values being measured, or to yield a full LSB value for each corresponding register.

7.5.3 Reading and Writing Telemetry Data and Warning Thresholds

All telemetry data are measured using a 16-bit ADC. Telemetry data and user-programmed warning thresholds are communicated in 16-bit, two's complement, signed data. Data are read or written in 2-byte increments conforming to the DIRECT format as described in section 8.3.3 of the [PMBus Power System Management Protocol Specification 1.3 Part II](#). Device telemetry uses all 16 bits of the internal ADC; however, the warning registers only use the upper 12 bits for out-of-range comparisons. See each individual warning command (IOUT_OC_WARN_LIMIT, VIN_OV_WARN_LIMIT, VIN_UV_WARN_LIMIT, and PIN_OP_WARN_LIMIT) for the format of the warning threshold word.

Programming (continued)

7.5.4 Reading Telemetry Data and Warning Thresholds

Conversion from direct format to real-world dimensions of current, voltage, and power is accomplished by determining the appropriate coefficients as described in section 7.2.1 of the *PMBus Power System Management Protocol Specification 1.3 Part II*. According to this specification, the host system converts the received values using Equation 3 into a reading of volts, amperes, watts, or other such units.

$$X = \frac{1}{m} (Y \times 10^{-R} - b)$$

where

- X = the calculated real-world value (volts, amps, watts, and so forth)
- m = the slope coefficient
- Y = a 2-byte, two's complement integer received from the device
- b = the offset, which is a 2-byte, two's complement integer
- R = the exponent, which is a 1-byte, two's complement integer
- R is only necessary in systems where m is required to be an integer (for example, where m can be stored in a register of an integrated circuit) and R must only be large enough to yield the desired accuracy (3)

The values for m and R (listed in Table 1) must be calculated for current and power measurements based off the selected value of the Current_LSB. For example, assume a Current_LSB of 0.75 mA/bit is selected for a given application. The value for m is calculated by inverting the LSB value (for this case, $m = 1 / 0.00075 = 1333.333$). Moving the decimal point so the value of m is maximized and remains within the required range of –32768 to 32767 is preferable because this value of m is relatively small and contains decimal information. Moving the decimal point one place to the right results in a final m value of 13333 with an R value of –1 resulting from the shift in decimal location. Moving the decimal point to maximize the value of m is critical to minimize rounding errors. The m coefficient for power can be calculated by applying $1 / (25 \times \text{Current_LSB})$. For this example, the value for the m power coefficient is calculated to be 53.333. Again (to maximize accuracy), the decimal location is shifted by 2 to the right to give a final m value of 5333 with an R coefficient of –2. Care must be taken to adjust the exponent coefficient, R, such that the value of m remains within the range of –32768 to 32767. However, rounding errors resulting from the limitations on the value of m can be mitigated by carefully selecting a slightly higher current LSB size. For example, if a Current_LSB of 1 mA/bit is selected instead of 0.75 mA/bit, the calculated value for m is $1 / 0.001$ or 1000; because this value is a whole number there is no rounding errors and the value for R is 0. Positive values for R signify the number of times the decimal point is shifted to the left, whereas negative values for R signify the number of decimal point shifts to the right.

Table 1. Telemetry and Warning Conversion Coefficients (R_s in mΩ)

COMMANDS	FORMAT	NUMBER OF DATA BYTES	m	b	R	UNIT
READ_VIN VIN_OV_WARN_LIMIT VIN_UV_WARN_LIMIT	DIRECT	2	8	0	2	V
READ_IIN, READ_IOUT MFR_IIN_OC_WARN_LIMIT	DIRECT	2	Calculated from Current_LSB	0	Calculated	A
READ_PIN, READ_EIN MFR_PIN_OP_WARN_LIMIT	DIRECT	2	Calculated from Current_LSB	0	Calculated	W
MFR_READ_VSHUNT	DIRECT	2	4	0	5	V

7.5.4.1 Writing Telemetry Data and Warning Thresholds

There are several PMBus commands that require writing telemetry data in order to be used. Use the same coefficients previously calculated for the application and apply these coefficients using [Equation 4](#).

$$Y = (mX + b) \times 10^R$$

where

- X = the real-world value (volts, amps, watts, temperature, and so forth)
 - m = the slope coefficient, a 2-byte, two's complement integer
 - Y = a 2-byte, two's complement integer written to the device
 - b = the offset, which is a 2-byte, two's complement integer
 - R = the exponent, which is a 1-byte, two's complement integer
- (4)

7.5.5 System-Level Calibration With MFR_CALIBRATION Command

The calibration register also offers possibilities for end-user, system-level calibration. After determining the exact current by using an external ammeter, the value of the MFR_CALIBRATION register can then be adjusted (as shown in [Equation 5](#)) based on the measured current result of the INA233 to cancel the total system error.

$$\text{Corrected_Full_Scale_Cal} = \text{trunc}\left(\frac{\text{Cal} \times \text{MeasShuntCurrent}}{\text{Device_Reported_Current}}\right)$$

(5)

7.5.6 Bus Overview

The INA233 features an I²C-compatible, 2-wire interface with an open-drain Alert output. The data transfer format is SMBus version 3.0 compliant and the device supports multiple PMBus commands that allow the device to be easily used along with PMBus version 1.3 devices.

The device that initiates a data transfer is called a *master*, and the devices controlled by the master are *slaves*. The bus must be controlled by a master device that generates the serial clock (SCL), controls the bus access, and generates START and STOP conditions.

To address a specific device, the master initiates a START condition by pulling the data signal line (SDA) from a high to a low logic level when SCL is high. All slaves on the bus shift in the slave address byte on the rising edge of SCL, with the last bit indicating whether a read or write operation is intended. During the ninth clock pulse, the slave being addressed responds to the master by generating an Acknowledge and pulling SDA low.

Data transfer is then initiated and eight bits of data are sent, followed by an Acknowledge bit. During data transfer, SDA must remain stable when SCL is high. Any change in SDA when SCL is high is interpreted as a START or STOP condition.

After all data are transferred, the master generates a STOP condition, indicated by pulling SDA from low to high when SCL is high. The device includes a 28-ms timeout on the interface to prevent bus lockup.

7.5.6.1 Serial Bus Address

To communicate with the INA233, the master must first address slave devices via a slave address byte. The slave address byte consists of seven address bits and a direction bit that indicates whether the action is to be a read or write operation.

The device has two address pins, A0 and A1. [Table 2](#) lists the pin logic levels for each of the 16 possible addresses. The device samples the state of the A0 and A1 pins on every bus communication. Establish the pin states before any activity on the interface occurs.

Table 2. Address Pins and Slave Addresses

A1	A0	SLAVE ADDRESS
GND	GND	1000000
GND	VS	1000001
GND	SDA	1000010
GND	SCL	1000011
VS	GND	1000100
VS	VS	1000101
VS	SDA	1000110
VS	SCL	1000111
SDA	GND	1001000
SDA	VS	1001001
SDA	SDA	1001010
SDA	SCL	1001011
SCL	GND	1001100
SCL	VS	1001101
SCL	SDA	1001110
SCL	SCL	1001111

7.5.6.2 Serial Interface

The INA233 operates only as a slave device on both the I²C bus and the SMBus. Connections to the bus are made via the open-drain SDA and SCL lines. The SDA and SCL pins feature integrated spike-suppression filters and Schmitt triggers to minimize the effects of input spikes and bus noise. Although the device integrates spike suppression into the digital I/O lines, proper layout techniques help minimize the amount of coupling into the communication lines. This noise introduction can occur from capacitively coupling signal edges between the two communication lines themselves or from other switching noise sources present in the system. Routing traces in parallel with ground in between layers on a printed circuit board (PCB) typically reduces the effects of coupling between the communication lines. Shielded communication lines reduce the possibility of unintended noise coupling into the digital I/O lines that can be incorrectly interpreted as START or STOP commands.

All data bytes are transmitted least significant byte first.

7.5.6.3 Writing to and Reading From the INA233

Both writing and reading to the INA233 is accomplished through the use of various PMBus commands. Each PMBus command code is an address that allows read or write access to the internal registers; see the [PMBus Command Support](#) section for a complete list of supported PMBus commands and corresponding addresses. The value for the command address is the first byte transferred after the slave address byte with the R/W bit low. Every write operation to the device requires a value for the command address.

Writing to the device begins with the first byte transmitted by the master. This byte is the slave address with the R/W bit low. The device then acknowledges receipt of a valid address. The next byte transmitted by the master is the PMBus command address to the register that data are written to. This command address value updates the register pointer to the desired register. The next two bytes are written to the register addressed by the PMBus command. The device acknowledges receipt of each data byte. The master can terminate data transfer by generating a START or STOP condition.

The timing structure for SEND BYTE commands is the same as WRITE WORD commands except no data packets are sent.

When reading from the device, first the device is written to with the desired PMBus command that is to return the desired value. This write is accomplished by issuing a slave address byte with the R/W bit low, followed by the PMBus command code. No additional data are required. The master then generates a repeated START condition and sends the slave address byte with the R/W bit high to initiate the read command. The next byte is transmitted by the slave and is the most significant byte of the register indicated by the register pointer. This byte is followed by an Acknowledge (ACK) from the master; then the slave transmits the least significant byte. The master acknowledges receipt of the data byte. The master can terminate data transfer by generating a Not-Acknowledge after receiving any data byte, or by generating a START or STOP condition. If repeated reads from the same register are desired, the register pointer bytes do not have to be continually sent; the device retains the register pointer value until the value is changed by the next write operation.

The READ BYTE format has the same timing structure as the READ WORD format except a byte of data is returned instead of a word.

Figure 26 shows the write operation timing diagram. Figure 27 shows the read operation timing diagram.

NOTE

Register bytes are sent least-significant byte first, followed by the most significant byte.

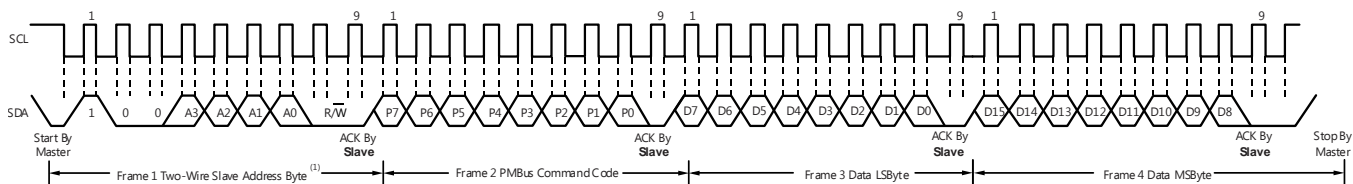

- (1) The value of the slave address byte is determined by the settings of the A0 and A1 pins; see [Table 2](#).

Figure 26. Timing Diagram for Write Word Format

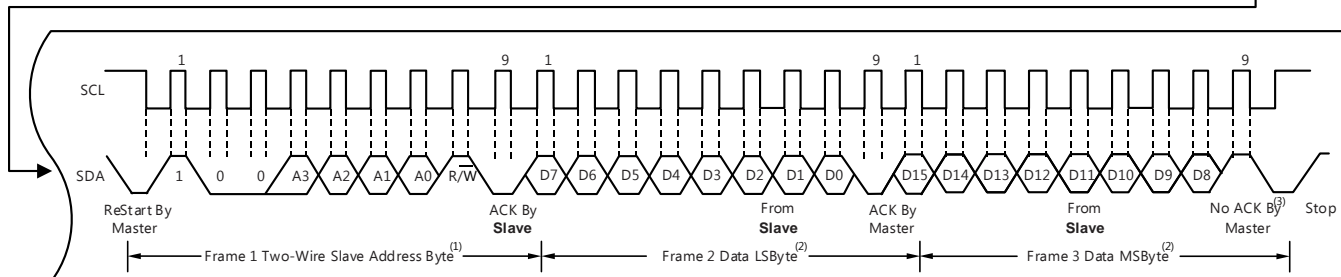
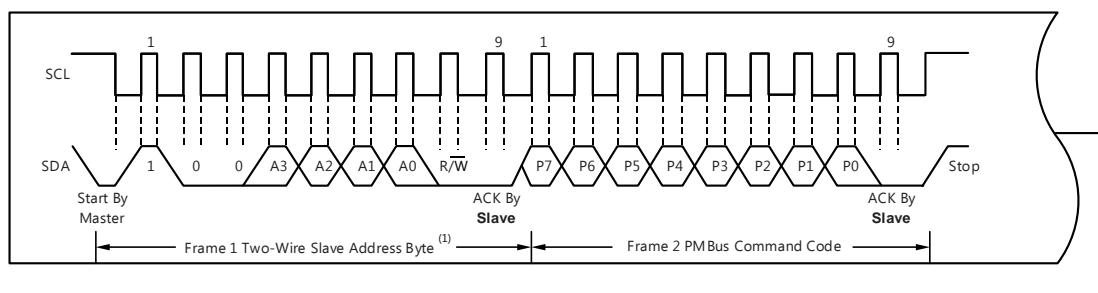

- (1) The value of the slave address byte is determined by the settings of the A0 and A1 pins; see [Table 2](#).
 (2) Read data are from the previous PMBus command code.
 (3) An Acknowledge by the master can also be sent.

Figure 27. Timing Diagram for Read Word Format

A block read is similar to the read word format in that first the device is written to with the desired PMBus command that is to return the desired value. This write is accomplished by issuing a slave address byte with the R/W bit low, followed by the PMBus command code. The master then generates a repeated START condition and sends the slave address byte with the R/W bit high to initiate the read command. The next byte is transmitted by the slave is the total number of bytes that are sent to the master. This byte is followed by an Acknowledge (ACK) from the master; then the slave transmits the first data byte. At the end of each byte the master sends an Acknowledge and the next byte is sent by the slave. The master can terminate data transfer by generating a Not-Acknowledge after receiving any data byte, or by generating a START or STOP condition.

Figure 28 shows the block read operation timing diagram. Figure 29 shows the timing diagram for the SMBus Alert response operation.

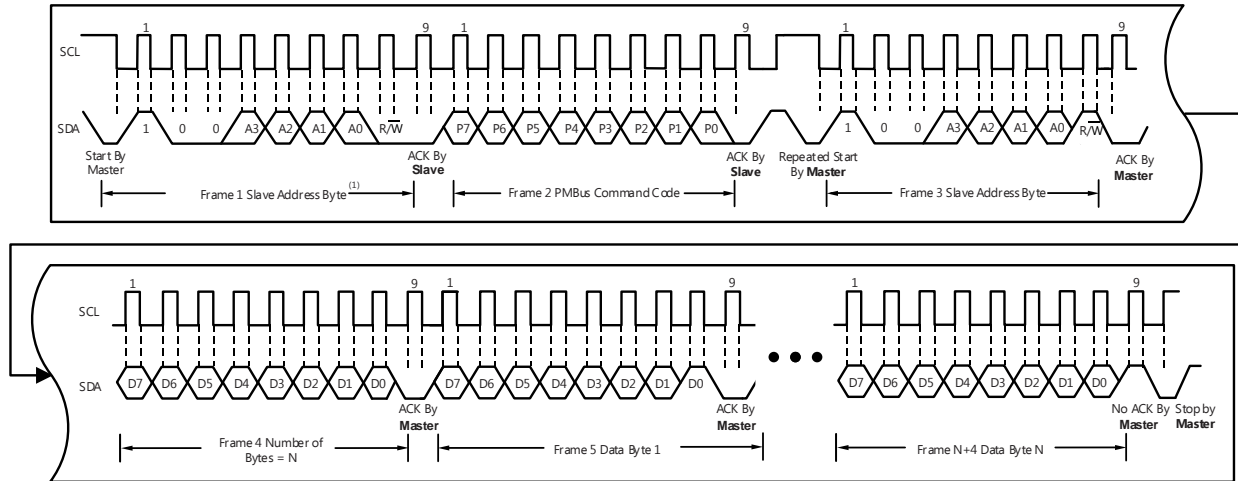

A. The value of the slave address byte is determined by the settings of the A0 and A1 pins; see Table 2.

Figure 28. Timing Diagram for Block Read Format

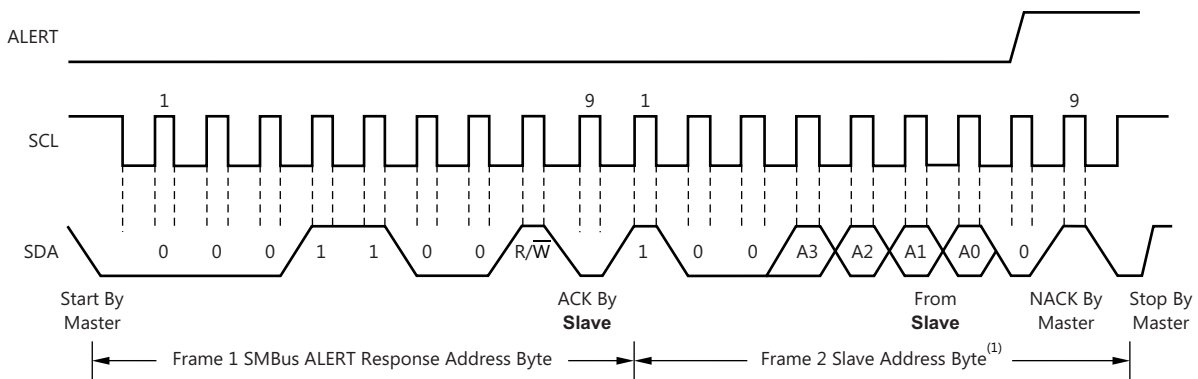

(1) The value of the slave address byte is determined by the settings of the A0 and A1 pins; see Table 2.

Figure 29. Timing Diagram for SMBus ALERT Response

7.5.6.3.1 Packet Error Checking

The INA233 supports packet error checking as described in the SMBus version 3.0 specification. Packet error checking is a method to improve the reliability and communication robustness of the digital interface. Packet error checking is implemented by appending a packet error code (PEC) at the end of each message transfer. To maximize compatibility, devices that support packet error checking must be able to communicate with the host and other devices that do not support the error checking protocol. Therefore, packet error checking can help improve the communication robustness when desired but is optional when not supported by the master or other devices on the bus. See the SMBus version 3.0 specification for additional details on implementing packet error checking in an SMBus environment.

7.5.6.3.2 Bus Timing Requirements

When the bus is idle, both the SDA and SCL lines are pulled high by the pullup resistors. The master generates a START condition followed by a valid serial byte containing high-speed (HS) master code `00001XXX`. This transmission can be made at 400-kHz data rates. Figure 30 shows a timing diagram for the bus and Table 3 lists the bus timing definitions.

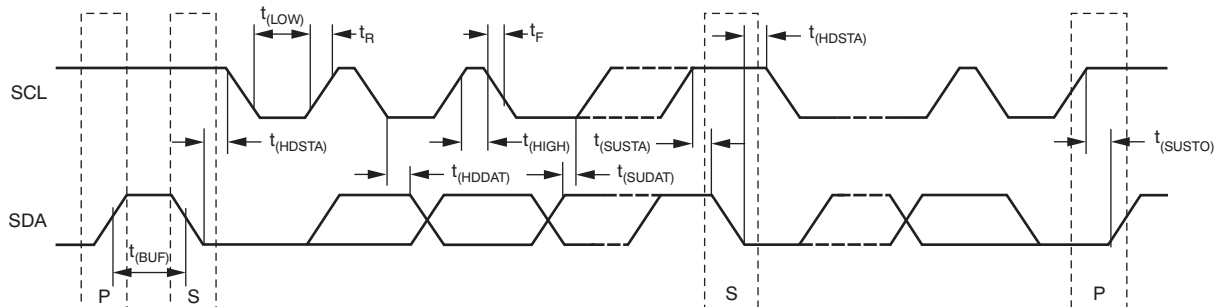

Figure 30. Bus Timing Diagram

Table 3. Bus Timing Definitions⁽¹⁾

		MIN	MAX	UNIT
$f_{(SCL)}$	SCL operating frequency	10	400	kHz
$t_{(BUF)}$	Bus free time between STOP and START conditions	0.6		μ s
$t_{(HDSTA)}$	Hold time after a repeated START condition. After this period, the first clock is generated.	0.6		μ s
$t_{(SUSTA)}$	Repeated START condition setup time	0.6		μ s
$t_{(SUSTO)}$	STOP condition setup time	0.6		μ s
$t_{(HDDAT)}$	Data hold time	0		ns
$t_{(SUDAT)}$	Data setup time	100		ns
$t_{(LOW)}$	SCL clock low period	1.3		μ s
$t_{(HIGH)}$	SCL clock high period	0.6	50	μ s
t_F	Data fall time		300	ns
t_F	Clock fall time		300	ns
t_R	Clock rise time		300	ns

(1) Values are based on a statistical analysis of a one-time sample of devices. Minimum and maximum values are not specified and are not production tested.

7.5.6.4 SMBus Alert Response

When SMBus alerts are latched, the INA233 is designed to respond to the SMBus alert response address. The SMBus alert response provides a quick fault identification for simple slave devices. When an alert occurs, the master can broadcast the alert response slave address (0001 100) with the R/\overline{W} bit set high. Following this alert response, any slave device that generates an alert is identified by acknowledging the alert response and sending its address on the bus.

The alert response can activate several different slave devices simultaneously, similar to the I²C general call. If more than one slave attempts to respond, bus arbitration rules apply and the device with the lowest address wins and is serviced first. The losing devices do not generate an Acknowledge and continue to hold the alert line low until the interrupt is cleared. The winning device responds with its address and releases the SMBus alert line. Even though the INA233 releases the SMBus line, the internal error flags are not cleared until done so by the host.

7.6 Register Maps

7.6.1 PMBus Command Support

The device features an SMBus interface that allows the use of PMBus commands to set warn levels, error masks, and obtain telemetry on bus voltage, current, power, and shunt voltage. [Table 4](#) lists the supported PMBus commands.

Table 4. Supported PMBus Commands

CODE	NAME	FUNCTION	R/W	NUMBER OF DATA BYTES	DEFAULT VALUE
03h	CLEAR_FAULTS	Clears the status registers and rearms the black box registers for updating	Send byte	0	N/A
12h	RESTORE_DEFAULT_ALL	Restores internal registers to the default values	Send byte	0	N/A
19h	CAPABILITY	Retrieves the device capability	R	1	B0h
4Ah	IOUT_OC_WARN_LIMIT	Retrieves or stores the output overcurrent warn limit threshold	R/W	2	7FF8h
57h	VIN_OV_WARN_LIMIT	Retrieves or stores the input overvoltage warn limit threshold	R/W	2	7FF8h
58h	VIN_UV_WARN_LIMIT	Retrieves or stores the input undervoltage warn limit threshold	R/W	2	0000h
6Bh	PIN_OP_WARN_LIMIT	Retrieves or stores the output overpower warn limit threshold	R/W	2	7FF8h
78h	STATUS_BYTE	Retrieves information about the device operating status	R	1	00h
79h	STATUS_WORD	Retrieves information about the device operating status	R	2	1000h
7Bh	STATUS_IOUT	Retrieves information about the output current status	R/W, CLR	1	00h
7Ch	STATUS_INPUT	Retrieves information about the input status	R/W, CLR	1	00h
7Eh	STATUS_CML	Retrieves information about the communications status	R/W, CLR	1	00h
80h	STATUS_MFR_SPECIFIC	Retrieves information about the manufacturer specific device status	R/W, CLR	1	20h
86h	READ_EIN	Retrieves the energy reading measurement	Block read	6	00h, 00h, 00h, 00h, 00h, 00h
88h	READ_VIN	Retrieves the measurement for the VBUS voltage	R	2	0000h
89h	READ_IN	Retrieves the input current measurement, supports both positive and negative currents	R	2	0000h
8Bh	READ_VOUT	Mirrors READ_VIN	R	2	0000h
8Ch	READ_IOUT	Mirror of READ_IN for compatibility	R	2	0000h
96h	READ_POUT	Mirror of READ_PIN for compatibility with possible VBUS connections	R	2	0000h
97h	READ_PIN	Retrieves the input power measurement	R	2	0000h
99h	MFR_ID	Retrieves the manufacturer ID in ASCII characters (TI)	Block read	2	54h, 49h
9Ah	MFR_MODEL	Retrieves the device number in ASCII characters (INA233)	Block read	6	49h, 4Eh, 41h, 32h, 33h, 33h
9Bh	MFR_REVISION	Retrieves the device revision letter and number in ASCII (for instance, A0)	R	2	41h, 30h
D0h	MFR_ADC_CONFIG	Configures the ADC averaging modes, conversion times, and operating modes	R/W	2	4127h
D1h	MFR_READ_VSHUNT	Retrieves the shunt voltage measurement	R	2	0000h
D2h	MFR_ALERT_MASK	Allows masking of device warnings	R/W	1	F0h

Register Maps (continued)
Table 4. Supported PMBus Commands (continued)

CODE	NAME	FUNCTION	R/W	NUMBER OF DATA BYTES	DEFAULT VALUE
D4h	MFR_CALIBRATION	Allows the value of the current-sense resistor calibration value to be input. Must be programmed at power-up. Default value is set to 1.	R/W	2	0001h
D5h	MFR_DEVICE_CONFIG	Allows the ALERT pin polarity to be changed	R/W	1	02h
D6h	CLEAR_EIN	Clears the energy accumulator	Send byte	0	N/A
E0h	TI_MFR_ID	Returns a unique word for the manufacturer ID	R	2	ASCII TI, 5449h
E1h	TI_MFR_MODEL	Returns a unique word for the manufacturer model	R	2	ASCII 33
E2h	TI_MFR_REVISION	Returns a unique word for the manufacturer revision	R	2	ASCII A0

7.6.2 Standard PMBus Commands
7.6.2.1 CLEAR_FAULTS (03h)

CLEAR_FAULTS is a standard PMBus command that resets all stored warning and fault flags and the alert signal. If a fault or warning condition still exists when the CLEAR_FAULTS command is issued, the ALERT signal clears but reasserts almost immediately. This command uses the PMBus send byte protocol.

7.6.2.2 RESTORE_DEFAULT_ALL (12h)

The RESTORE_DEFAULT_ALL command restores the internal device register settings to the default values.

NOTE

When issued, values in the calibration register are cleared and must be reconfigured by the master.

7.6.2.3 CAPABILITY (19h)

The CAPABILITY command is a standard PMBus command that returns information about the PMBus functions supported by the INA233. This command is read with the PMBus read byte protocol.

Table 5. CAPABILITY Register

VALUE	MEANING	DEFAULT
B0h	Supports packet error check, 400 kbits/sec, supports SMBus alert response address (ARA)	B0h

7.6.2.4 IOUT_OC_WARN_LIMIT (4Ah) [default = 01111111 1111000]

This command is an overcurrent warn limit. This standard PMBus command is used to set or read the threshold of the first level warning of high output currents. Use the PMBus read or write word protocol to access this command. The contents of the IOUT_OC_WARN_LIMIT register are compared to the current-sense ADC telemetry value to detect high output current. This warning threshold applies to both positive and negative currents.

Enter the value in the register in amps with the same scaling and coefficients used for reading current.

When this input overcurrent warning limit is exceeded, the device:

- Sets the NONE OF THE ABOVE bit in the STATUS_BYTE register
- Sets the IOUT bit in the STATUS_WORD register
- Sets the IOUT_OC_WARNING bit in the STATUS_IOUT register
- Sets the INPUT bit in the STATUS_WORD register
- Sets the IIN_OC_WARNING bit in the STATUS_INPUT register
- Notifies (if unmasked) the host using the ALERT pin

This warning is masked with the MFR_ALERT_MASK command with the IIN_OC_WARN bit.

See the [Reading and Writing Telemetry Data and Warning Thresholds](#) and [Writing Telemetry Data and Warning Thresholds](#) sections for additional information on reading and setting warning thresholds.

Figure 31. IOUT_OC_WARN_LIMIT

15	14	13	12	11	10	9	8
—	IO11	IO10	IO9	IO8	IO7	IO6	IO5
R-0	R/W-1	R/W-1	R/W-1	R/W-1	R/W-1	R/W-1	R/W-1
7	6	5	4	3	2	1	0
IO4	IO3	IO2	IO1	IO0	—	—	—
R/W-1	R/W-1	R/W-1	R/W-1	R/W-1	R-0	R-0	R-0

Table 6. IOUT_OC_WARN_LIMIT Field Descriptions

Bit	Field	Type	Default	Description
15	—	R	0	Reserved; always 0.
14:3	IO[11:0]	R/W	1	These bits control the IOUT_OC_WARN_LIMIT. The bit weightings in this register match the bit weightings in the READ_IOUT register (IO0 = I13).
2:0	—	R	0	Reserved; always 0.

7.6.2.5 VIN_OV_WARN_LIMIT (57h) [default = 01111111 11111000]

VIN_OV_WARN_LIMIT is a standard PMBus command that allows configuring or reading the threshold for a VBUS overvoltage warning detection. Use the coefficients listed in [Table 1](#) when reading and writing to this register. Use the PMBus read or write word protocol to access this command.

When this input overvoltage warning limit is exceeded, the device:

- Sets the NONE OF THE ABOVE bit in the STATUS_BYTE register
- Sets the INPUT bit in the STATUS_WORD register
- Sets the IOUT_OC_WARNING bit in the STATUS_INPUT register
- Notifies (if unmasked) the host using the ALERT pin

This fault is masked with the MFR_ALERT_MASK command using the VIN_OV_WARNING

See the [Reading and Writing Telemetry Data and Warning Thresholds](#) and [Writing Telemetry Data and Warning Thresholds](#) sections for additional information on reading and setting warning thresholds.

Full-scale range = 40.96 V (7FFFh) and LSB = 1.25 mV.

Figure 32. VIN_OV_WARN_LIMIT

15	14	13	12	11	10	9	8
—	V11	V10	V9	V8	V7	V6	V5
R-0	R/W-1	R/W-1	R/W-1	R/W-1	R/W-1	R/W-1	R/W-1
7	6	5	4	3	2	1	0
V4	V3	V2	V1	V0	—	—	—
R/W-1	R/W-1	R/W-1	R/W-1	R/W-1	R-0	R-0	R-0

Table 7. VIN_OV_WARN_LIMIT Field Descriptions

Bit	Field	Type	Default	Description
15	—	R	0	Reserved; always 0.
14:3	V[11:0]	R/W	1	These bits control the VIN_OV_WARN_LIMIT. The bit weightings in this register match the bit weightings in the READ_VIN register (V0 = BV3).
2:0	—	R/W	0	Reserved; always 0.

7.6.2.6 VIN_UV_WARN_LIMIT (58h) [default = 00000000 00000000]

VIN_UV_WARN_LIMIT is a standard PMBus command that allows configuring or reading the threshold for the VBUS undervoltage warning detection. Use the coefficients listed in [Table 1](#) when reading and writing to this register. Use the PMBus read or write word protocol to access this command.

When this input undervoltage warning limit is exceeded, the device:

- Sets the NONE OF THE ABOVE bit in the STATUS_BYTE register
- Sets the INPUT bit in the STATUS_WORD register
- Sets the VIN_UV_WARNING bit in the STATUS_INPUT register
- Notifies (if unmasked) the host using the ALERT pin

This fault is masked with the MFR_ALERT_MASK command using the VIN_UV_WARNING bit.

See the [Reading and Writing Telemetry Data and Warning Thresholds](#) and [Writing Telemetry Data and Warning Thresholds](#) sections for additional information on reading and setting warning thresholds.

Full-scale range = 40.96 V (7FFFh) and LSB = 1.25 mV.

Figure 33. VIN_UV_WARN_LIMIT

15	14	13	12	11	10	9	8
—	V11	V10	V9	V8	V7	V6	V5
R-0	R/W-0	R/W-0	R/W-0	R/W-0	R/W-0	R/W-0	R/W-0
7	6	5	4	3	2	1	0
V4	V3	V2	V1	V0	—	—	—
R/W-0	R/W-0	R/W-0	R/W-0	R/W-0	R-0	R-0	R-0

Table 8. VIN_UV_WARN_LIMIT Field Descriptions

Bit	Field	Type	Default	Description
15	—	R	0	Reserved; always 0.
14:3	V[11:0]	R/W	0	These bits control the VIN_UV_WARN_LIMIT. The bit weightings in this register match the bit weightings in the READ_VIN register (V0 = BV3).
2:0	—	R	0	Reserved; always 0.

7.6.2.7 PIN_OP_WARN_LIMIT (6Bh) [default = 11111111 11110000]

PIN_OP_WARN_LIMIT is a standard PMBus command that allows setting or reading the threshold for the input overpower warning. Use the PMBus read or write word protocol to access the POUT_OP_WARN_LIMIT command. The contents of this register are compared to the calculated telemetry power value.

When the PIN_OP_WARN_LIMIT is exceeded, the device:

- Sets the INPUT bit in the upper byte of the STATUS_WORD register
- Sets the PIN_OP_WARNING bit in the STATUS_INPUT register
- Notifies the host by asserting the ALERT pin

This warning is masked with the MFR_ALERT_MASK command using the IIN_OP_WARNING bit.

Figure 34. PIN_OP_WARN_LIMIT

15		14		13		12		11		10		9		8	
D11		D10		D9		D8		D7		D6		D5		D4	
R/W-1		R/W-1		R/W-1		R/W-1		R/W-1		R/W-1		R/W-1		R/W-1	
7		6		5		4		3		2		1		0	
D3		D2		D1		D0		—		—		—		—	
R/W-1		R/W-1		R/W-1		R/W-1		R-0		R-0		R-0		R-0	

Table 9. PIN_OP_WARN_LIMIT Field Descriptions

Bit	Field	Type	Default	Description
15:4	D[11:0]	R/W	1	These bits control the VIN_UV_WARN_LIMIT. The bit weightings in this register match the bit weightings in the READ_PIN register (D0 = P4).
3:0	—	R	0	Reserved; always 0.

7.6.2.8 STATUS_BYTE (78h)

STATUS_BYTE is a standard PMBus command that returns the value of a number of flags indicating the state of the INA233. Use the PMBus read byte protocol to access this command. To clear bits in this register, clear the underlying fault and issue a CLEAR_FAULTS command. [Table 10](#) lists the definitions for this command.

Table 10. STATUS_BYTE Definitions

BIT	NAME	MEANING	DEFAULT
7	BUSY	Not supported	0
6	OFF	Not supported	0
5	VOUT_OV	Not supported	0
4	IOUT_OC	Not supported	0
3	VIN_UV	Not supported	0
2	TEMPERATURE	Not supported	0
1	CML	A communication fault has occurred	0
0	NONE OF THE ABOVE	A fault or warning not listed in bits[7:1] has occurred	0

NONE OF THE ABOVE (bit 0) is set by the logical OR of the following status bits from other registers:

- IOUT_OC_WARNING
- VIN_OV_WARNING
- VIN_UV_WARNING
- IIN_OC_WARNING

This bit can only be cleared by clearing all the contributing status bits.

7.6.2.9 STATUS_WORD (79h)

STATUS_WORD is a standard PMBus command that returns the value of a number of flags indicating the state of the INA233. Use the PMBus read word protocol to access this command. To clear bits in this register, clear the underlying fault and issue a CLEAR_FAULTS command. The INPUT and VIN UV flags default to 1 on startup. [Table 11](#) lists the definitions for this command.

Table 11. STATUS_WORD Definitions

BIT	NAME	MEANING	DEFAULT
15	VOUT	Not supported	0
14	IOUT/POUT	An output current or power warning has occurred	0
13	INPUT	An input voltage, current, or power warning has occurred	0
12	MFR	A manufacturer-specific fault or warning has occurred	1
11	POWER_GOOD#	Not supported	0
10	FANS	Not supported	0
9	OTHER	Not supported	0
8	UNKNOWN	Not supported	0
7	BUSY	Not supported	0
6	OFF	Not supported	0
5	VOUT_OV	Not supported	0
4	IOUT_OC	Not supported	0
3	VIN_UV	Not supported	0
2	TEMPERATURE	Not supported	0
1	CML	A communication fault has occurred	0
0	NONE OF THE ABOVE	A fault or warning not listed in bits[7:1] has occurred	0

7.6.2.10 STATUS_IOUT (7Bh)

STATUS_IOUT is a standard PMBus command that returns the value of the of a number of flags related to output, current, and power. Use the PMBus read byte protocol to access this command. To clear bits in this register, clear the underlying fault and issue a CLEAR_FAULTS command or write a 1 to the bit to be cleared. [Table 12](#) lists the definitions for this command.

Table 12. STATUS_IOUT Definitions

BIT	NAME	MEANING	DEFAULT
7	IOUT_OC fault	Not supported	0
6	IOUT_OC fault with LV shutdown	Not supported	0
5	IOUT_OC_WARN	An input undercurrent warning has occurred	0
4	IOUT_UC fault	Not supported	0
3	Current share fault	Not supported	0
2	In power-limiting mode	Not supported	0
1	POUT_OP fault	Not supported	0
0	POUT_OP_WARN	Not supported	0

7.6.2.11 STATUS_INPUT (7Ch)

STATUS_INPUT is a standard PMBus command that returns the value of the of a number of flags related to input voltage, current, and power. Use the PMBus read byte protocol to access this command. To clear bits in this register, clear the underlying fault and issue a CLEAR_FAULTS command or write a 1 to the bit to be cleared. [Table 13](#) lists the definitions for this command.

Table 13. STATUS_INPUT Definitions

BIT	NAME	MEANING	DEFAULT
7	VIN_OV fault	Not supported	0
6	VIN_OV_WARN	An input overvoltage warning has occurred	0
5	VIN_UV_WARN	An input undervoltage warning has occurred	0
4	VIN_UV fault	Not supported	0
3	Insufficient voltage	Not supported	0
2	IIN_OC fault	Not supported	0
1	IIN_OC_WARN	An input overcurrent warning has occurred	0
0	PIN_OP_WARN	An input overpower warning has occurred	0

7.6.2.12 STATUS_CML (7Eh)

STATUS_CML is a standard PMBus command that returns the value of a number of flags related to communication faults. Use the PMBus read byte protocol to access this command. To clear bits in this register, issue a CLEAR_FAULTS command or write a 1 to the bit to be cleared. [Table 14](#) lists the definitions for this command.

Table 14. STATUS_CML Definitions

BIT	MEANING	DEFAULT
7	Invalid or unsupported command received	0
6	Not supported	0
5	Packet error check failed	0
4	Memory fault detected (trim fuse CRC failed, ECC active)	0
3	Not supported	0
2	Reserved	0
1	Not supported	0
0	Not supported	0

7.6.2.13 STATUS_MFR_SPECIFIC (80h)

STATUS_MFR_SPECIFIC is a standard PMBus command that contains manufacturer-specific status information. Use the PMBus read byte protocol to access this command. To clear bits in this register, clear the underlying fault and issue a CLEAR_FAULTS command or write a 1 to the bit to be cleared. Table 15 lists the definitions for this command.

Table 15. STATUS_MFR_SPECIFIC Definitions

BIT	MEANING	DEFAULT
7	Conversion ready	0
6	Arithmetic overflow flag. If the bit is set to 1 then an arithmetic operation results from an overflow error. This bit indicates that either the current or power data is invalid.	0
5	Power-on-reset event detected. To detect power-on or power glitch events, this bit must be cleared after initial power up. If power is interrupted this bit is reset to the default value of 1.	1
4	Communications or memory fault (or of STATUS_CML)	0
3	Input overpower warning	0
2	Input overcurrent warning	0
1	Input overvoltage warning	0
0	Input undervoltage warning	0

7.6.2.14 READ_EIN (86h)

READ_EIN is a command that returns information that the host can use to calculate energy or to average input power consumption. Use the PMBus block read protocol to access this command. Six bytes of data are returned by this command. The first two bytes are the 16-bit, unsigned output of an accumulator that continuously sums samples of the instantaneous input power. These two data bytes are formatted such that returned values can be converted to watts using the power m, b, and R coefficients. The third data byte is a count of the rollover events for the accumulator. This byte is an unsigned integer indicating the number of times that the accumulator has rolled over from the maximum positive value (FFFFh) to zero. The last three data bytes are a 24-bit unsigned integer that counts the number of samples of the instantaneous input power that are applied to the accumulator.

The combination of the accumulator and the rollover count can overflow within a few seconds depending on the ADC conversion time. The host software must detect and appropriately handle this overflow. Similarly, the sample count value overflows, but this event only occurs one time every few hours using 1-ms ADC conversion times.

To convert the data obtained with the READ_EIN command to average power, first convert the accumulator and rollover count to an unsigned integer.

Total Accumulated Unscaled Power (Accumulator₂₄) = (rollover_count × 2¹⁶) + Accumulator

Overflow detection and handling are done on the 24 bits of accumulator data and the sample count now. As shown in Equation 6, data from the previous calculation must be saved and used in this calculation to obtain the unscaled average power. Table 16 lists the definitions for this command.

$$\frac{\text{Accumulator}_{24}[n] - \text{Accumulator}_{24}[n-1]}{\text{Sample_count}[n] - \text{Sample_count}[n-1]}$$

where

- accumulator₂₄[n] = Overflow corrected, 24-bit accumulator data from this read
- Sample_count[n] = Sample count data from this read
- accumulator₂₄[n-1] = Overflow corrected 24-bit accumulator data from the previous read Sample_count[n-1] = Sample count data from the previous read
- Unscaled average power is now in the same units as the data from the READ_PIN command
- PMBus coefficients are used to convert the unscaled average power to watts

(6)

Table 16. READ_EIN Definitions

BYTE	MEANING	DEFAULT
6	Sample count high byte	0
5	Sample count mid byte	0
4	Sample count low byte	0
3	Power accumulator rollover count	0
2	Power accumulator high byte	0
1	Power accumulator low byte	0
0	Number of bytes	6

When the average power is calculated over a known number of samples, energy can be calculated by taking the product of the average power and the time interval for that average. The time interval can be externally measured or calculated by multiplying the number of samples reported by the ADC conversion time inclusive of any device averaging modes. However, calculating the energy consumption using the ADC conversion time results in a 10% error in the energy reading because of variations in the internal sampling oscillator. For increased precision in the energy measurement, using a higher accuracy external time measurement method is recommended.

The energy accumulator can be configured by the MFR_DEVICE_CONFIG command to automatically clear with each READ_EIN command. The ability to clear the accumulator on a read permits the device to be easily synchronised to an external timer and allows the accumulator to always start at 0, thus eliminating the need to subtract the initial accumulated values and sample counts.

The READ_EIN power accumulator can also be cleared by issuing a CLEAR_EIN command or RESTORE_DEFAULTS_ALL command. Clearing the power accumulator with the RESTORE_DEFAULTS_ALL command is not recommended because this command also clears the calibration register used to scale the accumulated power.

7.6.2.15 READ_VIN (88h)

READ_VIN is a standard PMBus command that returns the 16-bit measured value of the input voltage as read from the VBUS pin. Use the coefficients listed in [Table 1](#) to read this register. Use the PMBus read word protocol to access this command. This value is also used internally for the VIN_OV_WARN and VIN_UV_WARN detection.

Table 17. READ_VIN Register

VALUE	MEANING	DEFAULT
0h–7FFFh	Measured value for VBUS	0000h

Full-scale range = 40.96 V (7FFFh) and LSB = 1.25 mV.

7.6.2.16 READ_IIN (89h)

READ_IN is a standard PMBus command that returns the 16-bit signed value of the sensed current. Use the PMBus read word protocol to access this command. This value is also used internally for the IOUT_OC_WARN detection.

Table 18. READ_IIN Register

VALUE	MEANING	DEFAULT
0000h–FFFFh	Measured value for I _{IN}	0000h

If averaging is enabled, this register displays the averaged value. The value returned by the READ_IIN command is calculated by multiplying the decimal value in the READ_VHSUNT_OUT register with the decimal value of the MFR_CALIBRATION register.

7.6.2.17 READ_VOUT (8Bh)

This command is a mirror of the READ_VIN command supported for cases where VBUS is connected to the output.

7.6.2.18 READ_IOUT (8Ch, R)

This command is a mirror of the READ_IOUT command for software compatibility.

7.6.2.19 READ_POUT (96h, R)

READ_POUT is mirror of the READ_PIN command to support applications that connect the VBUS pin to the output.

7.6.2.20 READ_PIN (97h, R)

READ_PIN is a standard PMBus command that returns the 16-bit measured unsigned absolute value of the input power when VBUS is connected to the input.

Use the PMBus read word protocol to access this command. This value is also used internally for the POUT_OP_WARN detection.

Table 19. READ_PIN Register

VALUE	MEANING	DEFAULT
0h–FFFFh	Measured value for PIN	0000h

7.6.2.21 MFR_ID (99h)

MFR_ID is a standard PMBus command that returns the identification of the manufacturer. Use the PMBus block read protocol to read the manufacturer ID.

Table 20. MFR_ID Register

BYTE	NAME	VALUE
0	Number of bytes	02h
1	MFR ID-1	54h, ASCII (T)
2	MFR ID-2	49h, ASCII (I)

7.6.2.22 MFR_MODEL (9Ah)

MFR_MODEL is a standard PMBus command that returns the part number of the device. Use the PMBus block read protocol to read the manufacturer model.

Table 21. MFR_MODEL Register

BYTE	NAME	VALUE
0	Number of bytes	06h
1	MFR MODEL-1	49h, ASCII (I)
2	MFR MODEL-2	4Eh, ASCII (N)
3	MFR MODEL-3	41h, ASCII (A)
4	MFR MODEL-4	32h, ASCII (2)
5	MFR MODEL-5	33h, ASCII (3)
6	MFR MODEL-6	33h, ASCII (3)

7.6.2.23 MFR_REVISION (9Bh)

MFR_REVISION is a standard PMBus command that returns the revision level of the device. Use the PMBus block read protocol to read the manufacturer revision.

Table 22. MFR_REVISION Register

BYTE	NAME	VALUE
0	Number of bytes	02h
1	MFR REV-1	41h, ASCII (A)
2	MFR REV-2	41h, ASCII (0)

7.6.3 Manufacturer-Specific PMBus Commands

7.6.3.1 MFR_ADC_CONFIG (D0h) [default = 01000001 00100111]

The MFR_ADC_CONFIG command settings control the operating modes for the device ADC. This command controls the conversion time settings for both the shunt and bus voltage measurements as well as the averaging mode used. The operating mode that controls what signals are selected to be measured is also set with this command. Reading with the MFR_ADC_CONFIG command can be done at any time without affecting the device settings or a conversion in progress. Writing with the MFR_ADC_CONFIG command halts any conversion in progress until the write sequence is completed, resulting in a new conversion starting based on the updated contents. This halt prevents any uncertainty in the conditions used for the next completed conversion.

Figure 35. MFR_ADC_CONFIG

15	14	13	12	11	10	9	8
—	—	—	—	AVG2	AVG1	AVG0	VBUSCT2
R-0	R-1	R-0	R-0	R/W-0	R/W-0	R/W-0	R/W-1
7	6	5	4	3	2	1	0
VBUSCT1	VBUSCT0	VSHCT2	VSHCT1	VSHCT0	MODE3	MODE2	MODE1
R/W-0	R/W-0	R/W-1	R/W-0	R/W-0	R/W-1	R/W-1	R/W-1

Table 23. MFR_ADC_CONFIG Field Descriptions

Bit	Field	Type	Default	Description
15	—	R	0	Reserved.
14			1	
13:12			0	
11	AVG2	R/W	0	Averaging mode.
10	AVG1	R/W	0	These bits determine the number of samples that are collected and averaged. Table 24 lists AVG bit settings and related number of averages for each bit setting.
9	AVG0	R/W	0	
8	VBUSCT2	R/W	1	
7	VBUSCT1	R/W	0	These bits set the conversion time for the bus voltage measurement. Table 25 lists the VBUSCT bit options and related conversion times for each bit setting.
6	VBUSCT0	R/W	0	
5	VSHCT2	R/W	1	Shunt voltage conversion time.
4	VSHCT1	R/W	0	These bits set the conversion time for the shunt voltage measurement. Table 26 lists the VSHCT bit options and related conversion times for each bit setting.
3	VSHCT0	R/W	0	
2:0	MODE[3:1]	R/W	1	Operating mode. These bits select the continuous, triggered, or power-down mode of operation. These bits default to continuous shunt and bus measurement mode. Table 27 lists the mode settings.

Table 24. AGV[2:0] Bit Setting Combinations

AVG2	AVG1	AVG0	NUMBER OF AVERAGES
0 (default)	0 (default)	0 (default)	1 (default)
0	0	1	4
0	1	0	16
0	1	1	64
1	0	0	128
1	0	1	256
1	1	0	512
1	1	1	1024

Table 25. VBUSCT[2:0] Bit Setting Combinations

VBUSCT2	VBUSCT1	VBUSCT0	CONVERSION TIME
0	0	0	140 μ s
0	0	1	204 μ s
0	1	0	332 μ s
0	1	1	588 μ s
1 (default)	0 (default)	0 (default)	1.1 ms (default)
1	0	1	2.116 ms
1	1	0	4.156 ms
1	1	1	8.244 ms

Table 26. VSHCT[2:0] Bit Setting Combinations

VSHCT2	VSHCT1	VSHCT0	CONVERSION TIME
0	0	0	140 μ s
0	0	1	204 μ s
0	1	0	332 μ s
0	1	1	588 μ s
1 (default)	0 (default)	0 (default)	1.1 ms (default)
1	0	1	2.116 ms
1	1	0	4.156 ms
1	1	1	8.244 ms

Table 27. Mode[3:1] Bit Settings Combinations

MODE3	MODE2	MODE1	MODE
0	0	0	Power-down (or shutdown)
0	0	1	Shunt voltage, triggered
0	1	0	Bus voltage, triggered
0	1	1	Shunt and bus, triggered
1	0	0	Power-down (or shutdown)
1	0	1	Shunt voltage, continuous
1	1	0	Bus voltage, continuous
1 (default)	1 (default)	1 (default)	Shunt and bus, continuous (default)

7.6.3.2 MFR_READ_VSHUNT (D1h) [default = 00000000 00000000]

This register stores the current shunt voltage reading, V_{SHUNT} . Negative numbers are represented in two's-complement format. Generate the two's complement of a negative number by complementing the absolute value binary number and adding 1. An MSB = 1 denotes a negative number.

If averaging is enabled, this register displays the averaged value. Full-scale range = 81.92 mV (7FFFh) and LSB: 2.5 μ V.

This command only supports the PMBus direct data format.

Figure 36. MFR_READ_VSHUNT

15	14	13	12	11	10	9	8
Sign	SD14	SD13	SD12	SD11	SD10	SD9	SD8
R-0	R-0	R-0	R-0	R-0	R-0	R-0	R-0
7	6	5	4	3	2	1	0
SD7	SD6	SD5	SD4	SD3	SD2	SD1	SD0
R-0	R-0	R-0	R-0	R-0	R-0	R-0	R-0

Table 28. MFR_READ_VSHUNT Field Descriptions

Bit	Field	Type	Default	Description
15	Sign	R	0	This bit determines the sign for the returned value. 0 = Positive 1 = Negative
14:0	SD[14:0]	R	0	These bits set the shunt voltage data.

7.6.3.3 MFR_ALERT_MASK (D2h) [default = XXXXXXXX 11110000]

The bits in this register correspond to the bits in the STATUS_MFR_SPECIFIC register. Setting a bit in this register blocks the corresponding bit in the STATUS_MFR_SPECIFIC register from having an effect on the ALERT pin.

Figure 37. MFR_ALERT_MASK

7	6	5	4	3	2	1	0
Conversion ready	ADC overflow detected	POR event detected	Communications	IN_OP_WARNING	IN_OC_WARNING	IN_OV_WARNING	IN_UV_WARNING
R/W-1	R/W-1	R/W-1	R/W-1	R/W-0	R/W-0	R/W-0	R/W-0

Table 29. MFR_ALERT_MASK Field Descriptions

Bit	Field	Type	Default	Description
7	Conversion ready	R/W	1	Masks the conversion ready signal to the ALERT pin (masked by default).
6	ADC overflow detected	R/W	1	Masks the ADC overflow detection
5	POR event detected	R/W	1	Masks the detection of a power-on-reset event.
4	Communications	R/W	1	Communications or memory fault (or of STATUS_CML)
3	IN_OP_WARNING	R/W	0	Input overpower warning mask
2	IN_OC_WARNING	R/W	0	Input overcurrent warning mask
1	IN_OV_WARNING	R/W	0	Input overvoltage warning mask
0	IN_UV_WARNING	R/W	0	Input undervoltage warning mask

7.6.3.4 MFR_CALIBRATION (D4h) [default = 00000000 00000001]

This register provides the device with the value of the shunt resistor that was present to create the measured differential voltage. This register also sets the resolution of the current register. Programming this register sets the Current_LSB and the Power_LSB. This register is also suitable for use in overall system calibration. See the [Calibration Register and Scaling](#) section for additional information on programming the calibration register.

The Current_LSB can be used to scale the value in the READ_IOUT register.

Figure 38. MFR_CALIBRATION

15	14	13	12	11	10	9	8
—	CAL						
R/W-0	R/W-0	R/W-0	R/W-0	R/W-0	R/W-0	R/W-0	R/W-0
7	6	5	4	3	2	1	0
CAL							
R/W-0	R/W-0	R/W-0	R/W-0	R/W-0	R/W-0	R/W-0	R/W-1

Table 30. MFR_CALIBRATION Field Descriptions

Bit	Field	Type	Default	Description
15	—	R/W	0	Reserved
14:1	CAL	R/W	0	Calibration register value
0			1	

7.6.3.5 MFR_DEVICE_CONFIG (D5h) [default = 0000010]

This register configures various behaviors of the device in regards to data communications and alerts.

Figure 39. MFR_DEVICE_CONFIG

7	6	5	4	3	2	1	0
EIN_STATUS	Reserved	EIN_ACCUM		I2C_FILT	READ_EIN Autoclear	Alert Behavior	APOL
R/W-0	R/W-0	R/W-0		R/W-0	R/W-0	R/W-1	R/W-0

Table 31. MFR_DEVICE_CONFIG Field Descriptions

Bit	Field	Type	Default	Description
7	EIN_STATUS	R/W	0	0 = All values added to the EIN accumulator match the setting of EIN_ACCUM 1 = The EIN accumulator encountered a value inconsistent with the selected mode of operation. For EIN_ACCUM = 01, a negative value of the sign bit of READ_IIN is detected. For EIN_ACCUM = 10, a positive value of the sign bit of READ_IIN is detected. EIN_STATUS is not set when EIN_ACCUM is 00 or 11.
6	Reserved	R/W	0	Reserved
5:4	EIN_ACCUM	R/W	00	00, 11 = The READ_EIN accumulator sums all values of the READ_POUT register. Both negative and currents will increase the accumulator. 01 = The READ_EIN only sums positive values of the READ_POUT register based on the sign bit of the READ_IIN register; the sample count continues to increment for negative values 10 = The READ_EIN only sums negative values of the READ_POUT register based on the sign bit of the READ_IIN register; the sample count continues to increment for positive values
3	I2C_FILT	R/W	0	0 = Normal operation 1 = Disables the I ² C input filter
2	READ_EIN Autoclear	R/W	0	0 = Does not clear the sample count and accumulator 1 = Clears the sample count and accumulator after read
1	Alert Behavior	R/W	1	0 = Transparent 1 = Latched
0	APOL	R/W	0	Alert polarity bit. 0 = Normal 1 = Inverted

7.6.3.6 5.1.1 CLEAR_EIN (D6h)

No data are associated with this command.

This register clears the READ_EIN accumulator and counters. One sample of data may be lost.

7.6.3.7 TI_MFR_ID (E0h) [value = 01010100 01001001]
Figure 40. TI_MFR_ID

15	14	13	12	11	10	9	8
ID15	ID14	ID13	ID12	ID11	ID10	ID9	ID8
R-0	R-1	R-0	R-1	R-0	R-1	R-0	R-0
7	6	5	4	3	2	1	0
ID7	ID6	ID5	ID4	ID3	ID2	ID1	ID0
R-0	R-1	R-0	R-0	R-0	R-0	R-0	R-1

Table 32. TI_MFR_ID Field Descriptions

Bit	Field	Type	Value	Description
15	ID15	R	0	This command returns the same two bytes of data as the Read MFR_ID command except in an I ² C-compatible format of word read. The value that the device returns is ASCII TI (5449h).
14	ID14	R	1	
13	ID13	R	0	
12	ID12	R	1	
11	ID11	R	0	
10	ID10	R	1	
9:7	ID[9:7]	R	0	
6	ID6	R	1	
5:1	ID[5:1]	R	0	
0	ID0	R	1	

7.6.3.8 TI_MFR_MODEL (E1h) [value = 00110011 00110011]
Figure 41. TI_MFR_MODEL

15	14	13	12	11	10	9	8
MD15	MD14	MD13	MD12	MD11	MD10	MD9	MD8
R-0	R-0	R-1	R-1	R-0	R-0	R-1	R-1
7	6	5	4	3	2	1	0
MD7	MD6	MD5	MD4	MD3	MD2	MD1	MD0
R-0	R-0	R-1	R-1	R-0	R-0	R-1	R-1

Table 33. TI_MFR_MODEL Field Descriptions

Bit	Field	Type	Value	Description
15:14	MD[15:14]	R	0	This command returns the two bytes of data coded to represent the manufacturer model. The value that the device returns is ASCII 33.
13:12	MD[13:12]	R	1	
11:10	MD[11:10]	R	0	
9:8	MD[9:8]	R	1	
7:6	MD[7:6]	R	0	
5:4	MD[5:4]	R	1	
3:2	MD[3:2]	R	0	
1:0	MD[1:0]	R	1	

7.6.3.9 TI_MFR_REVISION (E2h) [value = 01000001 00110000]
Figure 42. TI_MFR_REVISION

15		14		13		12		11		10		9		8	
RV15		RV14		RV13		RV12		RV11		RV10		RV9		RV8	
R-0		R-1		R-0		R-0		R-0		R-0		R-0		R-1	
7		6		5		4		3		2		1		0	
RV7		RV6		RV5		RV4		RV3		RV2		RV1		RV0	
R-0		R-0		R-1		R-1		R-0		R-0		R-0		R-0	

Table 34. TI_MFR_REVISION Field Descriptions

Bit	Field	Type	Value	Description
15	RV[15]	R	0	This command returns the same two bytes of data as the Read MFR_REVISION command except in an I ² C-compatible format of word read. The value that the device returns is ASCII A0 (4130h).
14	RV[14]	R	1	
13:9	RV[13:9]	R	0	
8	RV[8]	R	1	
7:6	RV[7:6]	R	0	
5:4	RV[5:4]	R	1	
3:0	RV[3:0]	R	0	

8 Application and Implementation

NOTE

Information in the following applications sections is not part of the TI component specification, and TI does not warrant its accuracy or completeness. TI's customers are responsible for determining suitability of components for their purposes. Validate and test the design implementation to confirm system functionality.

8.1 Application Information

The INA233 is a current shunt and power monitor with an I²C-, SMBus-, and PMBus-compatible interface. The device monitors both a shunt voltage drop and bus supply voltage. Programmable calibration value, conversion times, and averaging (combined with an internal multiplier) enable direct readouts of current in amperes and power in watts.

8.2 Typical Application

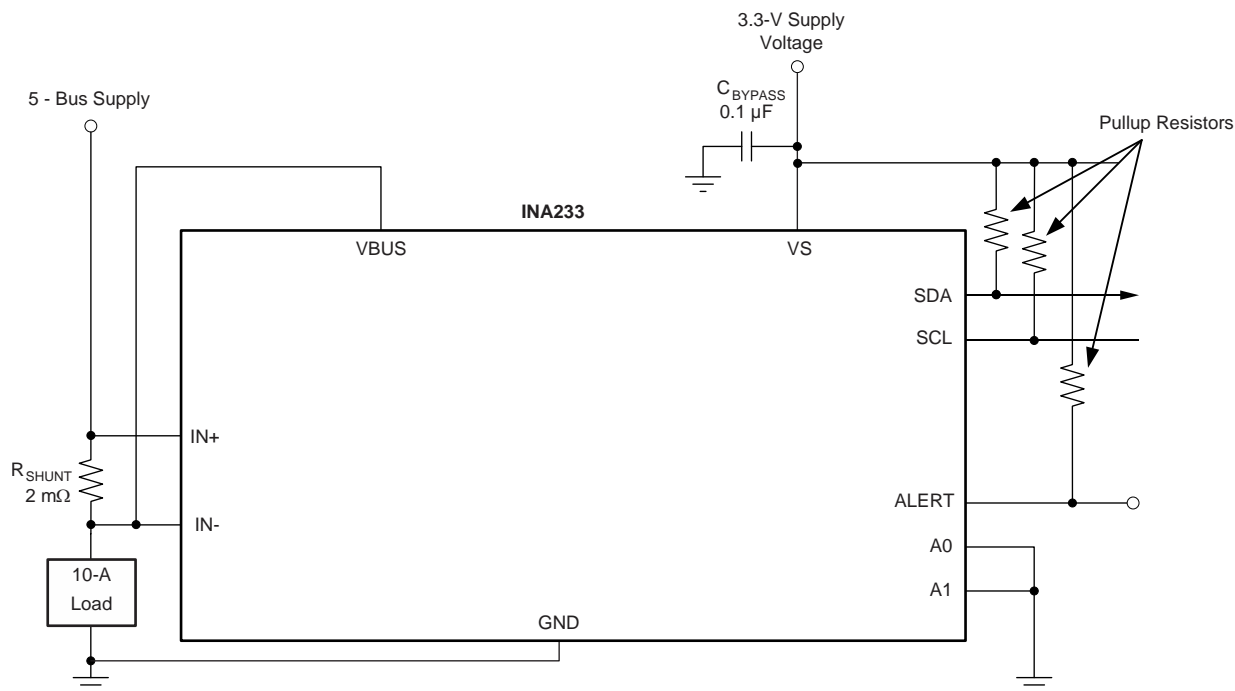

Copyright © 2017, Texas Instruments Incorporated

Figure 43. Typical High-Side Sensing Circuit Configuration, INA233

Typical Application (continued)

8.2.1 Design Requirements

The INA233 measures the voltage developed across a current-sensing resistor (R_{SHUNT}) when current passes through it. The device also measures the bus supply voltage and can calculate power when the calibration register is properly configured. The device comes with alert capability where the ALERT pin can be programmed to respond to a user-defined event or to a conversion ready notification. This design illustrates the ability of the ALERT pin to respond to a set input overvoltage threshold and how to correctly set the calibration registers and calculate returned values. [Table 35](#) details the requirements for this design.

Table 35. Design Requirements

PARAMETER	DESIGN TARGET
Power-supply voltage, V_S	5 V
Nominal bus supply voltage, V_{BUS}	5 V
VBUS overvoltage warning threshold	5.5 V
Nominal load current	10 A
Peak load current	15 A
Overcurrent warning threshold	15 A
R_{SHUNT}	2 m Ω

8.2.2 Detailed Design Procedure

This design example walks through the process of programming the calibration register, calculating the PMBus coefficients, setting the correct overvoltage and overcurrent warning thresholds, and how to properly scale returned values from the device. The device alert response time is also examined with 140- μ s and 1.1-ms ADC conversion rates.

8.2.2.1 Programming the Calibration Register

For this example, assuming a peak current of less than 15 A, the Current_LSB is calculated to be 457.7 μ A/bit using [Equation 2](#). Selecting a value for the Current_LSB of 500 μ A/bit or 1 mA/bit significantly simplifies the conversion of the returned value from the READ_IN and READ_PIN commands to amperes and watts. For this example, a value of 1 mA/bit is chosen for the Current_LSB. Using this value for the Current_LSB does trade a small amount of resolution for having a simpler conversion process on the user side. Using [Equation 1](#) in this example with a Current_LSB value of 1 mA/bit and a shunt resistor of 2 m Ω results in a MFR_CALIBRATION register value of 2560d (or A00h).

8.2.2.2 Calculating PMBus Coefficients

The m, b, and R coefficients are fixed for bus voltage measurements returned by the READ_VIN and READ_VOUT and are available from [Table 1](#).

For current and power measurements, the value for the m and R coefficients must be calculated. For current measurements returned by the READ_IIN and READ_IOUT commands, the value for m is calculated by inverting the Current_LSB used to set the MFR_CALIBRATION register and shifting the decimal location if needed to minimize rounding errors. In this example, using the Current_LSB of 1 mA/bit, the value of m is calculated to be 1000. Shifting the decimal location does not obtain higher accuracy because the value for m is a whole number. The value for R in this example is 0 because the decimal location for the value of m does not need shifting.

The POWER_LSB value is 25 times the value of the CURRENT_LSB, therefore, the value for m is reduced by a factor of 25. For this example, the value for the m power coefficient 1000 / 25 or 40. For this case, the R coefficient is also 0 because m is a whole number. If m is not a whole number, then shifting the decimal place is advantageous to reduce rounding errors while keeping the value between -32768 and 32767. Decimal shifts to the right result in negative values for R and shifts to the left result in positive values; the number of shifts is the absolute value of R.

The value of 0 can be used for b for both current and power measurements with very little loss in accuracy because the offset for power and current measurements is very low. The m, b, and R coefficients are fixed for bus voltage measurements returned by the READ_VIN and READ_VOUT and are available from [Table 1](#).

8.2.2.3 Programming Warning Thresholds

Warning thresholds are set by converting the warning value from volts, amperes, and watts to the appropriate digital word using Equation 4 with the correct values for m, b, and R. For example, to set a bus voltage overvoltage warning at 5.5 V with the VIN_OV_WARN_LIMIT command, the correct value to write with this command is 4400d or 1130h. The least significant last three bits of the 16-bit word are hard coded to 0 because the warning thresholds only have 12 bits of effective resolution. For this example there is no change to what is written in the VIN_OV_WARN_LIMIT register because the last three bits are already zero. To set an overcurrent warning level at 15 A with the IIN_OC_WARN_LIMIT command, the correct value to write to the device is 15000d (or 3A98h).

8.2.2.4 Calculating Returned Telemetry Values

When the value for the m, b, and R coefficients are known, returned values can be translated to volts, amperes, or watts by using Equation 3 with the calculated m, b, and R coefficients. Alternatively, returned values can be calculated by multiplying the returned code by the corresponding LSB size as discussed in the Calibration Register and Scaling section.

8.2.3 Application Curves

Figure 44 shows the ALERT pin response to a bus overvoltage limit of 5.6 V for a conversion time (t_{CT}) of 1.1 ms and averaging set to 1. Figure 45 shows the response for the same limit but with the conversion time reduced to 140 μ s. For the scope shots shown in these figures, persistence was enabled on the ALERT channel. Figure 44 and Figure 45 show how the ALERT response time can vary depending on when the fault condition occurs relative to the internal ADC clock of the INA233. For fault conditions that are just exceeding the limit threshold, the response time for the ALERT pin can vary from one to two conversion cycles. As mentioned previously, the variation is because of the timing on when the fault event occurs relative to the start time of the internal ADC conversion cycle. For fault events that greatly exceed the limit threshold, the alert can respond in less than one conversion cycle because fewer samples are required for the average to exceed the limit threshold value.

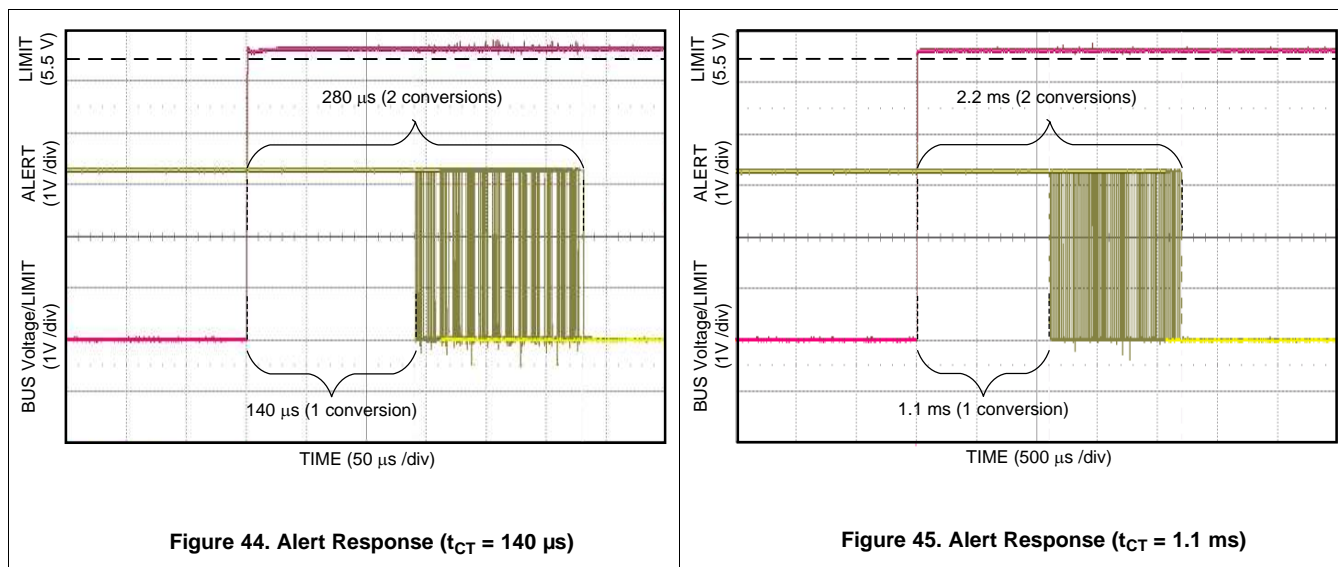

9 Power Supply Recommendations

The device input circuitry can accurately measure signals on common-mode voltages beyond the power-supply voltage, V_{VS} . For example, the voltage applied to the VS power supply pin can be 5 V, whereas the load power-supply voltage being monitored (the common-mode voltage) can be as high as 36 V. The device can also withstand the full 0-V to 36-V range at the input pins, regardless of whether the device has power applied or not.

Place the required power-supply bypass capacitors as close as possible to the supply and ground pins of the device to ensure stability. A typical value for this supply bypass capacitor is 0.1 μF . Applications with noisy or high-impedance power supplies can require additional decoupling capacitors to reject power-supply noise.

10 Layout

10.1 Layout Guidelines

Connect the input pins (IN+ and IN–) to the sensing resistor using a Kelvin connection or a 4-wire connection. These connection techniques ensure that only the current-sensing resistor impedance is detected between the input pins. Poor routing of the current-sensing resistor commonly results in additional resistance present between the input pins. Given the very low ohmic value of the current-sensing resistor, any additional high-current carrying impedance causes significant measurement errors. Place the power-supply bypass capacitor as close as possible to the supply and ground pins.

10.2 Layout Example

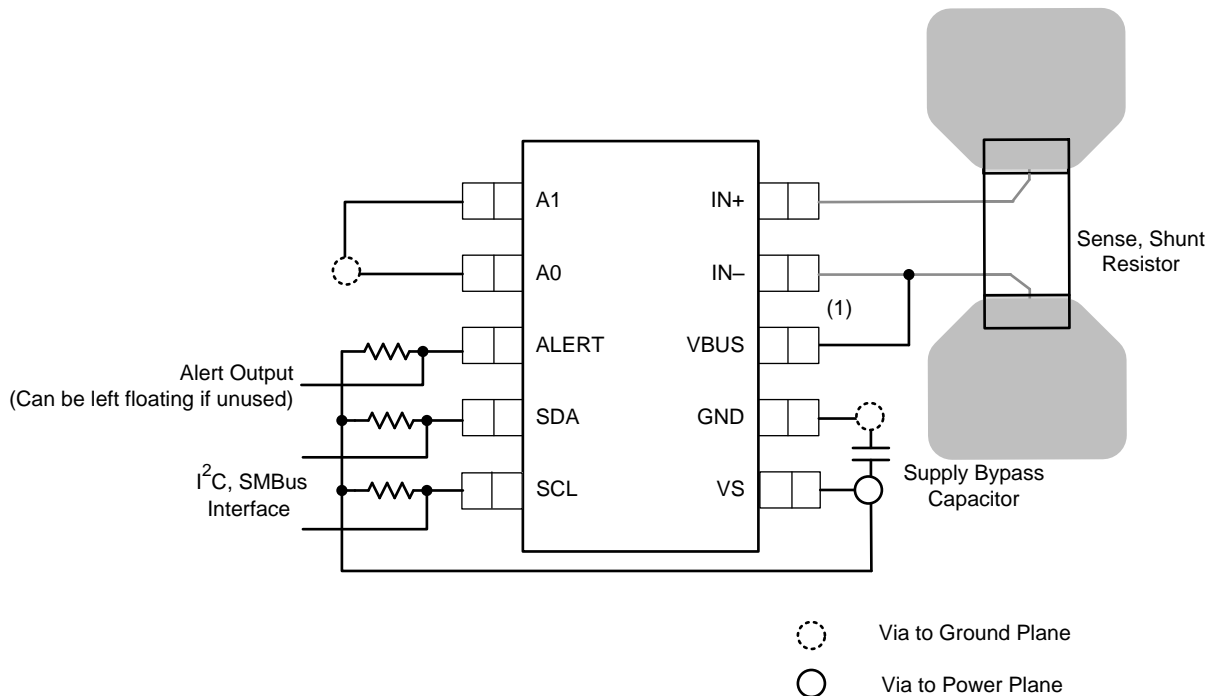

(1) Connect the VBUS pin to the power-supply rail.

Figure 46. INA233 Layout Example

11 Device and Documentation Support

11.1 Device Support

11.1.1 Development Support

- [INA226EVM Evaluation Board and Software Tutorial](#)

11.2 Documentation Support

11.2.1 Related Documentation

For related documentation see the following:

[Current Shunt Monitor with Transient Robustness Reference Design](#)

11.3 Receiving Notification of Documentation Updates

To receive notification of documentation updates, navigate to the device product folder on ti.com. In the upper right corner, click on *Alert me* to register and receive a weekly digest of any product information that has changed. For change details, review the revision history included in any revised document.

11.4 Community Resources

The following links connect to TI community resources. Linked contents are provided "AS IS" by the respective contributors. They do not constitute TI specifications and do not necessarily reflect TI's views; see TI's [Terms of Use](#).

TI E2E™ Online Community *TI's Engineer-to-Engineer (E2E) Community*. Created to foster collaboration among engineers. At e2e.ti.com, you can ask questions, share knowledge, explore ideas and help solve problems with fellow engineers.

Design Support *TI's Design Support* Quickly find helpful E2E forums along with design support tools and contact information for technical support.

11.5 Trademarks

E2E is a trademark of Texas Instruments.

All other trademarks are the property of their respective owners.

11.6 Electrostatic Discharge Caution



This integrated circuit can be damaged by ESD. Texas Instruments recommends that all integrated circuits be handled with appropriate precautions. Failure to observe proper handling and installation procedures can cause damage.

ESD damage can range from subtle performance degradation to complete device failure. Precision integrated circuits may be more susceptible to damage because very small parametric changes could cause the device not to meet its published specifications.

11.7 Glossary

[SLYZ022](#) — *TI Glossary*.

This glossary lists and explains terms, acronyms, and definitions.

12 Mechanical, Packaging, and Orderable Information

The following pages include mechanical, packaging, and orderable information. This information is the most current data available for the designated devices. This data is subject to change without notice and revision of this document. For browser-based versions of this data sheet, refer to the left-hand navigation.

PACKAGING INFORMATION

Orderable Device	Status (1)	Package Type	Package Drawing	Pins	Package Qty	Eco Plan (2)	Lead/Ball Finish (6)	MSL Peak Temp (3)	Op Temp (°C)	Device Marking (4/5)	Samples
INA233AIDGSR	PREVIEW	VSSOP	DGS	10	2500	TBD	Call TI	Call TI	-40 to 125		
INA233AIDGST	PREVIEW	VSSOP	DGS	10	250	TBD	Call TI	Call TI	-40 to 125		

(1) The marketing status values are defined as follows:

ACTIVE: Product device recommended for new designs.

LIFEBUY: TI has announced that the device will be discontinued, and a lifetime-buy period is in effect.

NRND: Not recommended for new designs. Device is in production to support existing customers, but TI does not recommend using this part in a new design.

PREVIEW: Device has been announced but is not in production. Samples may or may not be available.

OBSOLETE: TI has discontinued the production of the device.

(2) **RoHS:** TI defines "RoHS" to mean semiconductor products that are compliant with the current EU RoHS requirements for all 10 RoHS substances, including the requirement that RoHS substance do not exceed 0.1% by weight in homogeneous materials. Where designed to be soldered at high temperatures, "RoHS" products are suitable for use in specified lead-free processes. TI may reference these types of products as "Pb-Free".

RoHS Exempt: TI defines "RoHS Exempt" to mean products that contain lead but are compliant with EU RoHS pursuant to a specific EU RoHS exemption.

Green: TI defines "Green" to mean the content of Chlorine (Cl) and Bromine (Br) based flame retardants meet JS709B low halogen requirements of <=1000ppm threshold. Antimony trioxide based flame retardants must also meet the <=1000ppm threshold requirement.

(3) MSL, Peak Temp. - The Moisture Sensitivity Level rating according to the JEDEC industry standard classifications, and peak solder temperature.

(4) There may be additional marking, which relates to the logo, the lot trace code information, or the environmental category on the device.

(5) Multiple Device Markings will be inside parentheses. Only one Device Marking contained in parentheses and separated by a "~" will appear on a device. If a line is indented then it is a continuation of the previous line and the two combined represent the entire Device Marking for that device.

(6) Lead/Ball Finish - Orderable Devices may have multiple material finish options. Finish options are separated by a vertical ruled line. Lead/Ball Finish values may wrap to two lines if the finish value exceeds the maximum column width.

Important Information and Disclaimer: The information provided on this page represents TI's knowledge and belief as of the date that it is provided. TI bases its knowledge and belief on information provided by third parties, and makes no representation or warranty as to the accuracy of such information. Efforts are underway to better integrate information from third parties. TI has taken and continues to take reasonable steps to provide representative and accurate information but may not have conducted destructive testing or chemical analysis on incoming materials and chemicals. TI and TI suppliers consider certain information to be proprietary, and thus CAS numbers and other limited information may not be available for release.

In no event shall TI's liability arising out of such information exceed the total purchase price of the TI part(s) at issue in this document sold by TI to Customer on an annual basis.

DGS (S-PDSO-G10)

PLASTIC SMALL-OUTLINE PACKAGE



- NOTES:
- A. All linear dimensions are in millimeters.
 - B. This drawing is subject to change without notice.
 - C. Body dimensions do not include mold flash or protrusion.
 - D. Falls within JEDEC MO-187 variation BA.

IMPORTANT NOTICE

Texas Instruments Incorporated (TI) reserves the right to make corrections, enhancements, improvements and other changes to its semiconductor products and services per JESD46, latest issue, and to discontinue any product or service per JESD48, latest issue. Buyers should obtain the latest relevant information before placing orders and should verify that such information is current and complete.

TI's published terms of sale for semiconductor products (<http://www.ti.com/sc/docs/stdterms.htm>) apply to the sale of packaged integrated circuit products that TI has qualified and released to market. Additional terms may apply to the use or sale of other types of TI products and services.

Reproduction of significant portions of TI information in TI data sheets is permissible only if reproduction is without alteration and is accompanied by all associated warranties, conditions, limitations, and notices. TI is not responsible or liable for such reproduced documentation. Information of third parties may be subject to additional restrictions. Resale of TI products or services with statements different from or beyond the parameters stated by TI for that product or service voids all express and any implied warranties for the associated TI product or service and is an unfair and deceptive business practice. TI is not responsible or liable for any such statements.

Buyers and others who are developing systems that incorporate TI products (collectively, "Designers") understand and agree that Designers remain responsible for using their independent analysis, evaluation and judgment in designing their applications and that Designers have full and exclusive responsibility to assure the safety of Designers' applications and compliance of their applications (and of all TI products used in or for Designers' applications) with all applicable regulations, laws and other applicable requirements. Designer represents that, with respect to their applications, Designer has all the necessary expertise to create and implement safeguards that (1) anticipate dangerous consequences of failures, (2) monitor failures and their consequences, and (3) lessen the likelihood of failures that might cause harm and take appropriate actions. Designer agrees that prior to using or distributing any applications that include TI products, Designer will thoroughly test such applications and the functionality of such TI products as used in such applications.

TI's provision of technical, application or other design advice, quality characterization, reliability data or other services or information, including, but not limited to, reference designs and materials relating to evaluation modules, (collectively, "TI Resources") are intended to assist designers who are developing applications that incorporate TI products; by downloading, accessing or using TI Resources in any way, Designer (individually or, if Designer is acting on behalf of a company, Designer's company) agrees to use any particular TI Resource solely for this purpose and subject to the terms of this Notice.

TI's provision of TI Resources does not expand or otherwise alter TI's applicable published warranties or warranty disclaimers for TI products, and no additional obligations or liabilities arise from TI providing such TI Resources. TI reserves the right to make corrections, enhancements, improvements and other changes to its TI Resources. TI has not conducted any testing other than that specifically described in the published documentation for a particular TI Resource.

Designer is authorized to use, copy and modify any individual TI Resource only in connection with the development of applications that include the TI product(s) identified in such TI Resource. NO OTHER LICENSE, EXPRESS OR IMPLIED, BY ESTOPPEL OR OTHERWISE TO ANY OTHER TI INTELLECTUAL PROPERTY RIGHT, AND NO LICENSE TO ANY TECHNOLOGY OR INTELLECTUAL PROPERTY RIGHT OF TI OR ANY THIRD PARTY IS GRANTED HEREIN, including but not limited to any patent right, copyright, mask work right, or other intellectual property right relating to any combination, machine, or process in which TI products or services are used. Information regarding or referencing third-party products or services does not constitute a license to use such products or services, or a warranty or endorsement thereof. Use of TI Resources may require a license from a third party under the patents or other intellectual property of the third party, or a license from TI under the patents or other intellectual property of TI.

TI RESOURCES ARE PROVIDED "AS IS" AND WITH ALL FAULTS. TI DISCLAIMS ALL OTHER WARRANTIES OR REPRESENTATIONS, EXPRESS OR IMPLIED, REGARDING RESOURCES OR USE THEREOF, INCLUDING BUT NOT LIMITED TO ACCURACY OR COMPLETENESS, TITLE, ANY EPIDEMIC FAILURE WARRANTY AND ANY IMPLIED WARRANTIES OF MERCHANTABILITY, FITNESS FOR A PARTICULAR PURPOSE, AND NON-INFRINGEMENT OF ANY THIRD PARTY INTELLECTUAL PROPERTY RIGHTS. TI SHALL NOT BE LIABLE FOR AND SHALL NOT DEFEND OR INDEMNIFY DESIGNER AGAINST ANY CLAIM, INCLUDING BUT NOT LIMITED TO ANY INFRINGEMENT CLAIM THAT RELATES TO OR IS BASED ON ANY COMBINATION OF PRODUCTS EVEN IF DESCRIBED IN TI RESOURCES OR OTHERWISE. IN NO EVENT SHALL TI BE LIABLE FOR ANY ACTUAL, DIRECT, SPECIAL, COLLATERAL, INDIRECT, PUNITIVE, INCIDENTAL, CONSEQUENTIAL OR EXEMPLARY DAMAGES IN CONNECTION WITH OR ARISING OUT OF TI RESOURCES OR USE THEREOF, AND REGARDLESS OF WHETHER TI HAS BEEN ADVISED OF THE POSSIBILITY OF SUCH DAMAGES.

Unless TI has explicitly designated an individual product as meeting the requirements of a particular industry standard (e.g., ISO/TS 16949 and ISO 26262), TI is not responsible for any failure to meet such industry standard requirements.

Where TI specifically promotes products as facilitating functional safety or as compliant with industry functional safety standards, such products are intended to help enable customers to design and create their own applications that meet applicable functional safety standards and requirements. Using products in an application does not by itself establish any safety features in the application. Designers must ensure compliance with safety-related requirements and standards applicable to their applications. Designer may not use any TI products in life-critical medical equipment unless authorized officers of the parties have executed a special contract specifically governing such use. Life-critical medical equipment is medical equipment where failure of such equipment would cause serious bodily injury or death (e.g., life support, pacemakers, defibrillators, heart pumps, neurostimulators, and implantables). Such equipment includes, without limitation, all medical devices identified by the U.S. Food and Drug Administration as Class III devices and equivalent classifications outside the U.S.

TI may expressly designate certain products as completing a particular qualification (e.g., Q100, Military Grade, or Enhanced Product). Designers agree that it has the necessary expertise to select the product with the appropriate qualification designation for their applications and that proper product selection is at Designers' own risk. Designers are solely responsible for compliance with all legal and regulatory requirements in connection with such selection.

Designer will fully indemnify TI and its representatives against any damages, costs, losses, and/or liabilities arising out of Designer's non-compliance with the terms and provisions of this Notice.