

LOC	DIST	REVISIONS			
P	LTN	DESCRIPTION	DATE	DWN	APVD
CM	00	A3	ECR-15-006129	30APR2015	SC DZ

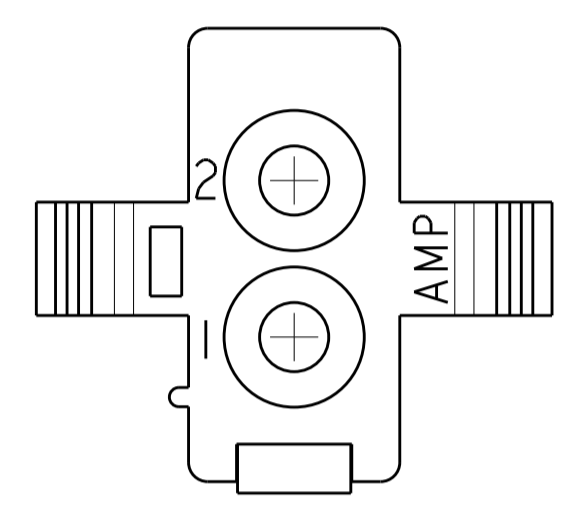

1. APPLICABLE CONTACT P/N: 170539, 170360, 170361, 170362.
2. MATING HOUSING P/N: 794894.
3. RECOMMENDED PANEL THICKNESS TO BE 0.8-2.0 [.031-.079].
4. HOUSING INSERTION INTO THE PANEL CUT OUT MUST BE IN THE SAME DIRECTION AS THE PUNCH.
5. GWT 750° (WITH OUT FLAME) ACC. IEC 60335-1
6. MATERIAL DESIGNATION.

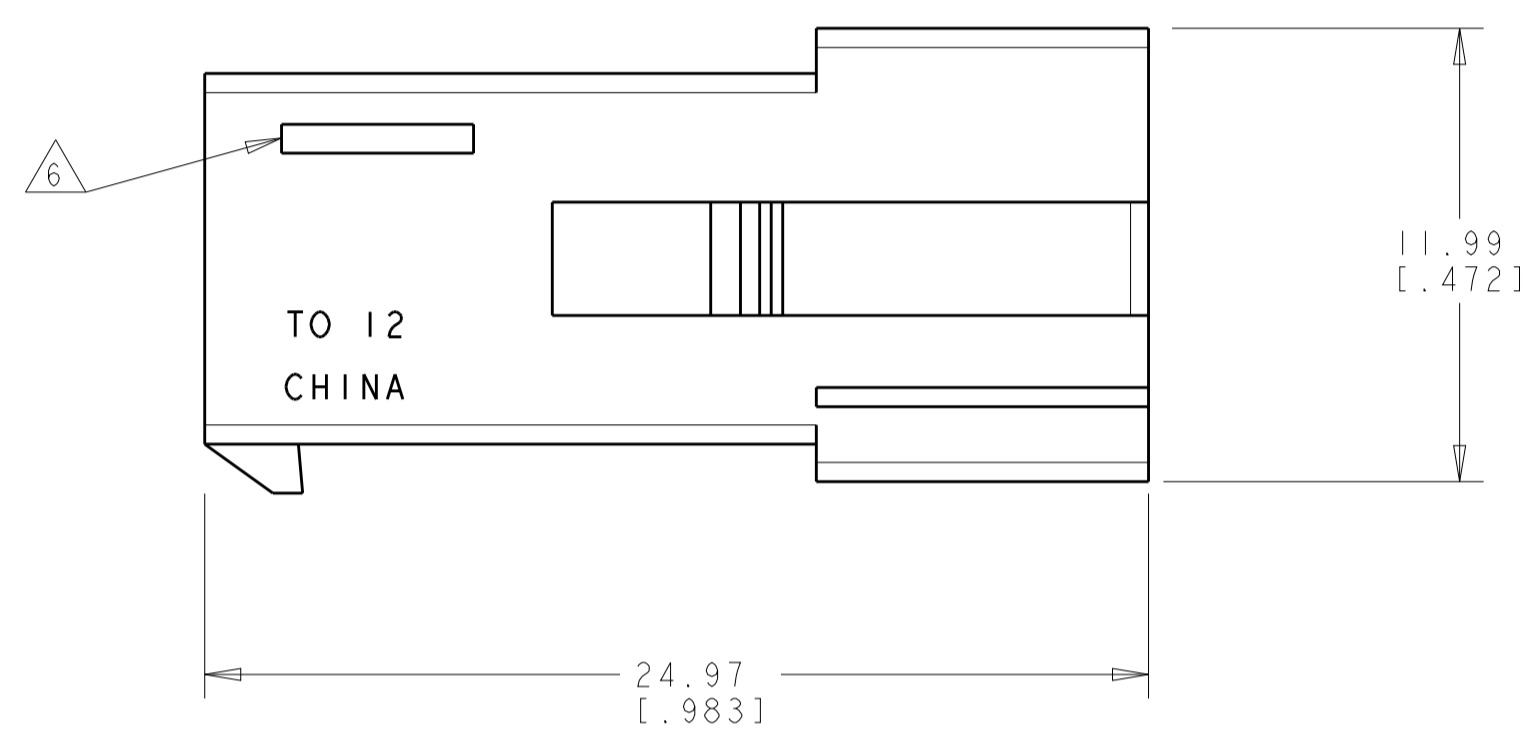
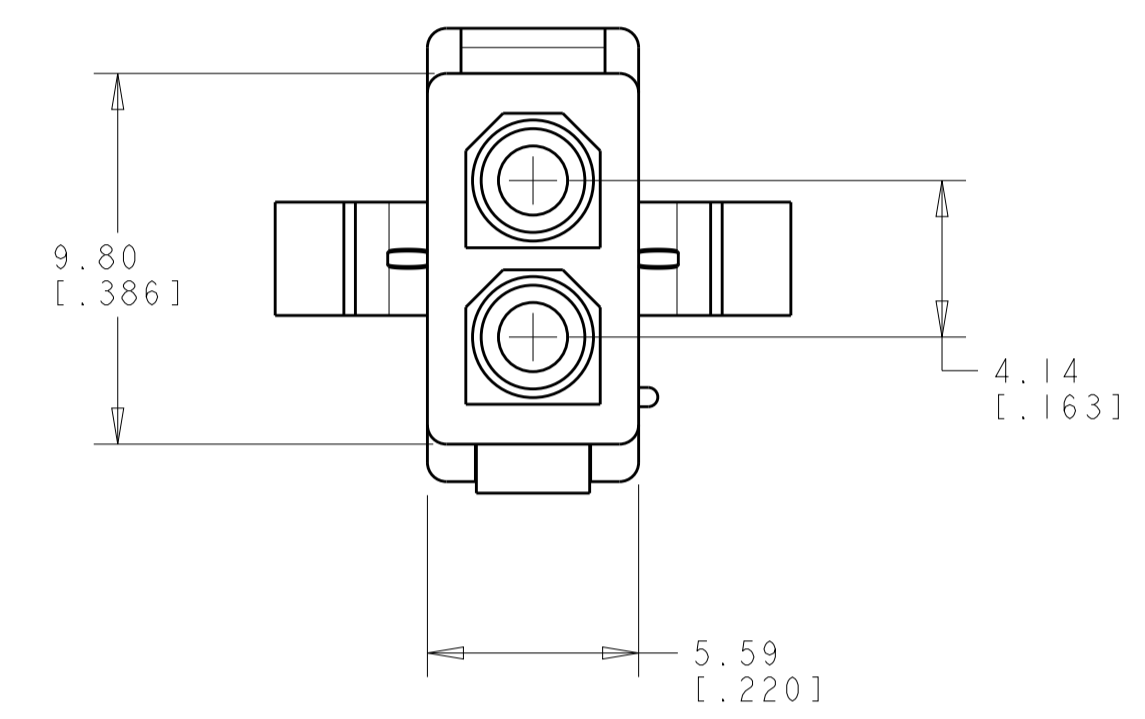
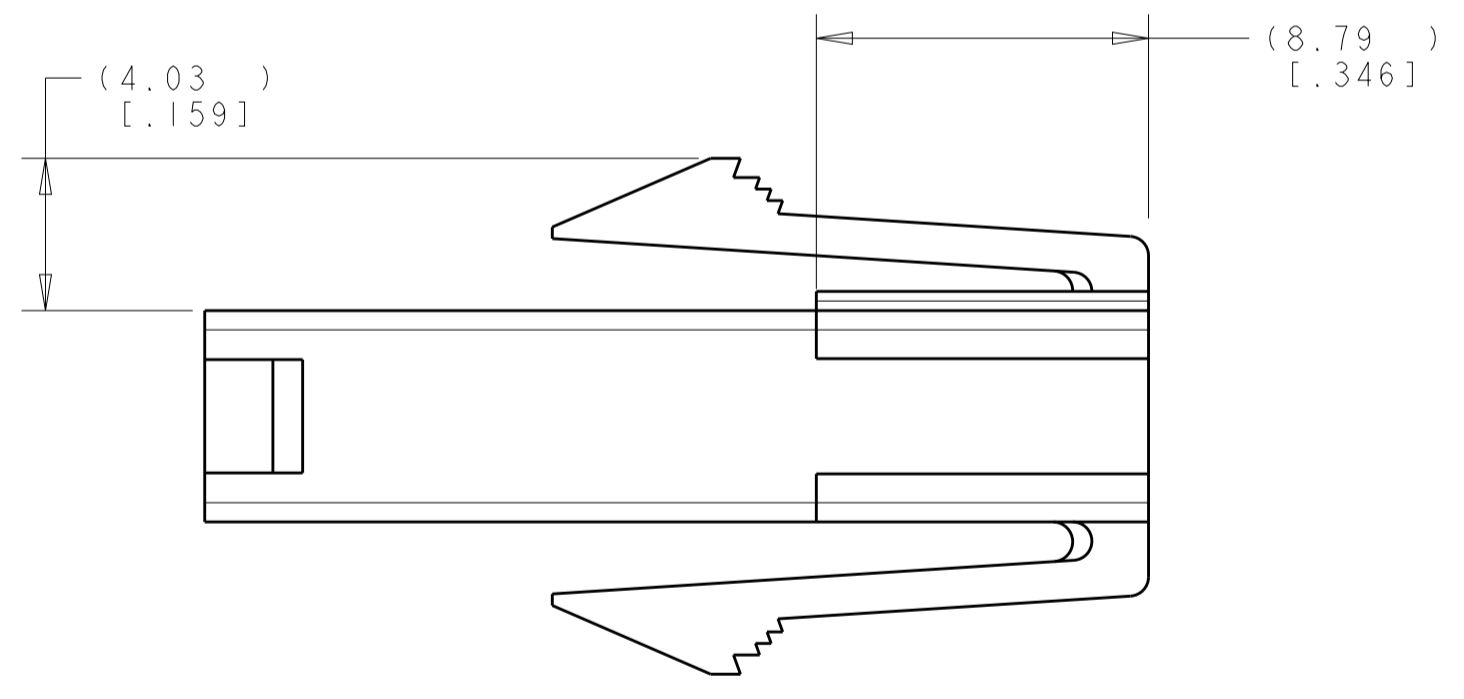
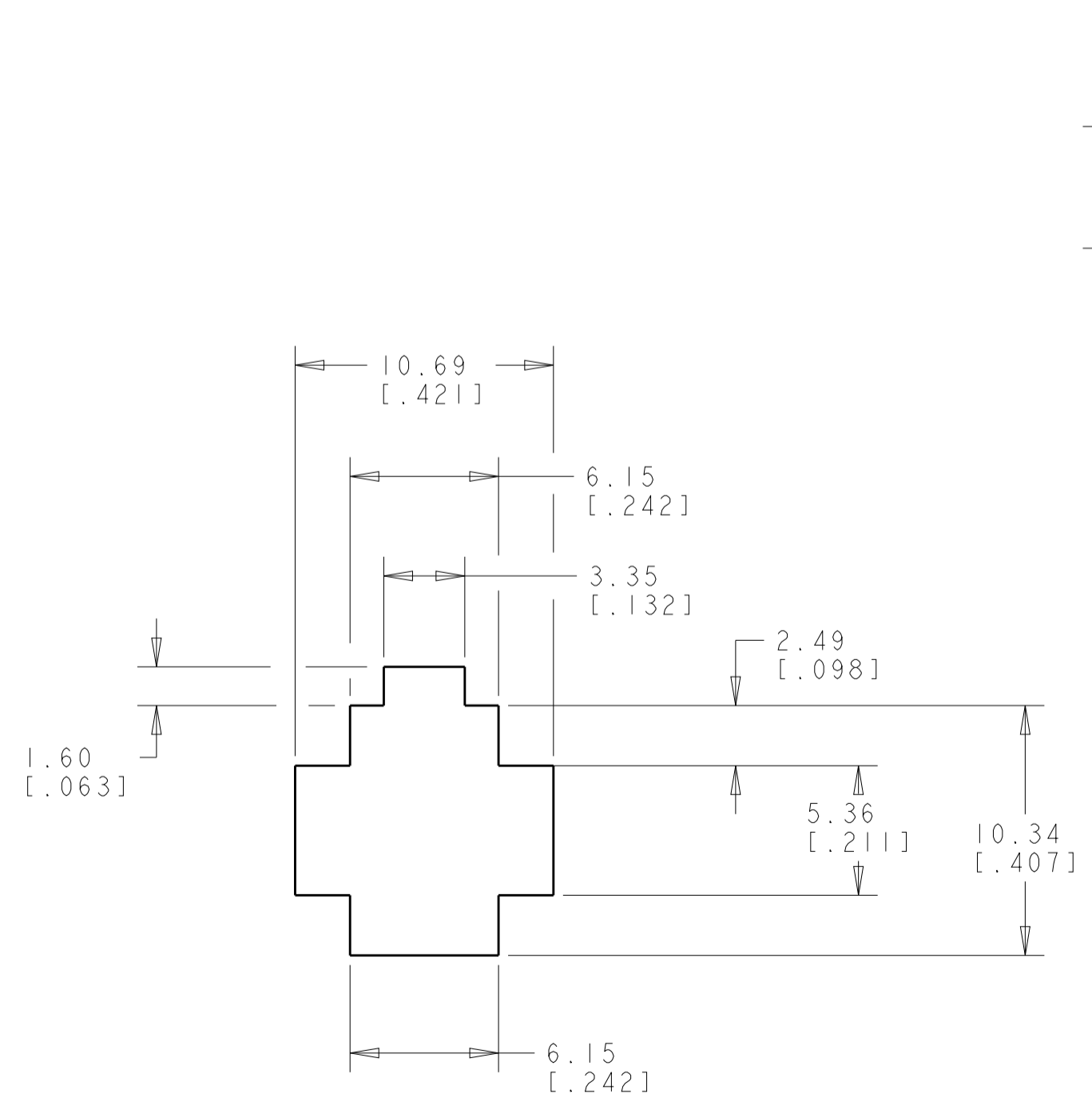

RECOMMENDED PANEL CUT OUT
SCALE 4:1

REMARKS	COLOUR	MATERIAL	PART NUMBER
5	NATURAL	PA6 UL94-V2	794896-3
5	RED	PA6 UL94-V2	794896-2
	NATURAL	PA66/6 UL94-V0	794896-1

THIS DRAWING IS A CONTROLLED DOCUMENT.		DWN R. WHITAKER 29JAN2001	NAME CAP, 2 CIRCUIT, SEALED APPLICATION, MINI UNIVERSAL MATE-N-LOK™	
DIMENSIONS: mm [INCHES]		CHK C. JONES 29JAN2001	PRODUCT SPEC	
TOLERANCES UNLESS OTHERWISE SPECIFIED:		APVD C. JONES 29JAN2001	APPLICATION SPEC	
0 PLC	±		SIZE	CAGE CODE
1 PLC	±		A1	794896
2 PLC	±0.13 (1.015)		SCALE	5:1
3 PLC	±.005		SHEET	1 OF 1
4 PLC	±		REV	A3
ANGLES	±		CUSTOMER DRAWING	
FINISH	±			

