

Click to view price, real time Inventory,
Delivery & Lifecycle Information ;

UCD9240RGCR

Texas instruments

Switching Controllers Dig Point of Load System Controller

Any questions, please feel free to contact us.

info@kaimte.com

Digital PWM System Controller

FEATURES

- Fully Configurable Multi-Output and Multi-Phase Non-Isolated DC/DC PWM Controller
- Controls Up To Four Voltage Rails and Up To Eight Phases
- Supports Switching Frequencies Up to 2MHz With 250 ps Duty-Cycle Resolution
- Up To 1mV Closed Loop Resolution
- Hardware-Accelerated, 3-Pole/3-Zero Compensator With Non-Linear Gain for Improved Transient Performance
- Supports Multiple Soft-Start and Soft-Stop Configurations Including Prebias Start-up
- Supports Voltage Tracking, Margining and Sequencing
- Supports Current and Temperature Balancing for Multi-Phase Power Stages
- Supports Phase Adding/Shedding for Multi-Phase Power Stages
- Sync In /Out Pins Align DPWM Clocks Between Multiple UCD9240 Devices
- Fan Monitoring and Control
- 12-Bit Digital Monitoring of Power Supply Parameters Including:
 - Input Current and Voltage
 - Output Current and Voltage
 - Temperature at Each Power Stage
- Multiple Levels of Overcurrent Fault Protection:
 - External Current Fault Inputs
 - Analog Comparators Monitor Current Sense Voltage
 - Current Continually Digitally Monitored
- Over and Undervoltage Fault Protection
- Overtemperature Fault Protection
- Enhanced Nonvolatile Memory With Error Correction Code (ECC)
- Device Operates From a Single Supply With an Internal Regulator Controller That Allows Operation Over a Wide Supply Voltage Range

- Supported by Fusion Digital Power™ Designer, a Full Featured PC Based Design Tool to Simulate, Configure, and Monitor Power Supply Performance.

APPLICATIONS

- Industrial/ATE
- Networking Equipment
- Telecommunications Equipment
- Servers
- Storage Systems
- FPGA, DSP and Memory Power

DESCRIPTION

The UCD9240 is a multi-rail, multi-phase synchronous buck digital PWM controller designed for non-isolated DC/DC power applications. This device integrates dedicated circuitry for DC/DC loop management with flash memory and a serial interface to support configurability, monitoring and management.

The UCD9240 was designed to provide a wide variety of desirable features for non-isolated DC/DC converter applications while minimizing the total system component count by reducing external circuits. The solution integrates multi-loop management with sequencing, margining, tracking and intelligent phase management to optimize for total system efficiency. Additionally, loop compensation and calibration are supported without the need to add external components.

To facilitate configuring the device, the Texas Instruments Fusion Digital Power™ Designer is provided. This PC based Graphical User Interface offers an intuitive interface to the device. This tool allows the design engineer to configure the system operating parameters for the application, store the configuration to on-chip non-volatile memory and observe both frequency domain and time domain simulations for each of the power stage outputs.

TI has also developed multiple complementary power stage solutions – from discrete drives in the UCD7k family to fully tested power train modules in the PTD family. These solutions have been developed to complement the UCD9k family of system power controllers.



Please be aware that an important notice concerning availability, standard warranty, and use in critical applications of Texas Instruments semiconductor products and disclaimers thereto appears at the end of this data sheet.

Fusion Digital Power, Auto-ID are trademarks of Texas Instruments.

PRODUCTION DATA information is current as of publication date. Products conform to specifications per the terms of the Texas Instruments standard warranty. Production processing does not necessarily include testing of all parameters.

Copyright © 2008, Texas Instruments Incorporated



These devices have limited built-in ESD protection. The leads should be shorted together or the device placed in conductive foam during storage or handling to prevent electrostatic damage to the MOS gates.

ORDERING INFORMATION⁽¹⁾

OPERATING TEMPERATURE RANGE, T _A	ORDERABLE PART NUMBER	PIN COUNT	SUPPLY	PACKAGE	TOP SIDE MARKING
-40 °C to 110 °C	UCD9240PFCR	80-pin	Reel of 1000	QFP	UCD9240
	UCD9240PFC	80-pin	Tray of 119	QFP	UCD9240
	UCD9240RGCR	64-pin	Reel of 2000	QFN	UCD9240
	UCD9240RGCT	64-pin	Reel of 250	QFN	UCD9240

(1) For the most current package and ordering information, see the Package Option Addendum at the end of this document, or see the TI web site at www.ti.com.

ELECTRICAL SPECIFICATIONS

ABSOLUTE MAXIMUM RATINGS⁽¹⁾

	VALUE	UNIT
Voltage applied at V33D to DV _{SS}	–0.3 to 3.8	V
Voltage applied at V33A to AV _{SS}	–0.3 to 3.8	V
Voltage applied to any pin ⁽²⁾	–0.3 to 3.8	V
Storage temperature (T _{STG})	–40 to 150	°C

(1) Stresses beyond those listed under *absolute maximum ratings* may cause permanent damage to the device. These are stress ratings only and functional operation of the device at these or any other conditions beyond those indicated under *recommended operating conditions* is not implied. Exposure to absolute-maximum-rated conditions for extended periods may affect device reliability.

(2) All voltages referenced to V_{SS}.

RECOMMENDED OPERATING CONDITIONS

Over operating free-air temperature range (unless otherwise noted).

		MIN	NOM	MAX	UNIT
V	Supply voltage during operation, V33D, V33DIO, V33A	3	3.3	3.6	V
T _A	Operating free-air temperature range	–40		110	°C
T _J	Junction temperature			125	°C

ELECTRICAL CHARACTERISTICS

PARAMETER		TEST CONDITIONS	MIN	NOM	MAX	UNIT
SUPPLY CURRENT						
I_{V33A}	Supply current	$V_{V33A} = 3.3\text{ V}$		8	15	mA
I_{V33DIO}		$V_{V33DIO} = 3.3\text{ V}$		2	10	
I_{V33D}		$V_{V33D} = 3.3\text{ V}$		40	45	
I_{V33D}		$V_{V33D} = 3.3\text{ V}$ storing configuration parameters in flash memory TBD		50	55	
INTERNAL REGULATOR CONTROLLER INPUTS/OUTPUTS						
V_{V33}	3.3-V linear regulator	Emitter of NPN transistor	3.25	3.3	3.35	V
V_{33FB}	3.3-V linear regulator feedback			4	4.6	
I_{V33FB}	Series pass base drive	$V_{VIN} = 12\text{ V}$		10		mA
Beta	Series NPN pass device		40			
EXTERNALLY SUPPLIED 3.3 V POWER						
V_{V33D} , $V_{V33DION}$	Digital 3.3-V power	$T_A = 25^\circ\text{ C}$	3.13		3.47	V
V_{V33A}	Analog 3.3-V power	$T_A = 25^\circ\text{ C}$	3.13		3.47	
ERROR AMPLIFIER INPUTS EAPn, EANN						
V_{CM}	Common mode voltage each pin		-0.15		1.848	V
V_{DIFF}	Differential Voltage Range		-0.256		1.998	
V_{ERROR}	Internal error Voltage range	AFE_GAIN field of CLA_GAINS = 0 ⁽¹⁾	-256		248	mV
EAP-EAN	Error voltage digital resolution	AFE_GAIN field of CLA_Gains = 3		1		
R_{EA}	Input Impedance	Ground reference	0.5	1.5	3	MΩ
I_{OFFSET}	Input offset current	1 kΩ source impedance	-5		5	
ANALOG INPUTS CS, V_{in}, TEMP, PMBusADDR						
I_{BIAS}	Bias current for PMBus Addr pins		9		11	μA
V_{ADDR_OPEN}	Voltage indicating open pin	AddrSens 0,1 open	2.47			
V_{ADDR_SHORT}	Voltage indicating shorted pin	AddrSense 0,1 short to ground			0.179	V
V_{ADC_RANGE}	Measurement range for voltage monitoring	Inputs: V_{in} , V_{track} , V_{temp} CS-1A, CS-1B, CS-2A, CS-2B CS-3A, CS-3B, CS-4A, CS-4B	0		2.5	
V_{OC_THRS}	Overcurrent comparator threshold voltage range	Inputs: CS-1A, CS-2A, CS-3A, CS-4A	0.032		2	V
V_{OC_RES}	Overcurrent comparator threshold voltage range	Inputs: CS-1A, CS-2A, CS-3A, CS-4A		31.25		
ADCREf	External Reference input	(80-pin package)	1.8		V33A	V
Temp _{internal}	Int. temperature sense accuracy	Over range from 0 °C to 100°C	-5		5	
INL	ADC integral nonlinearity		-2.5		2.5	mV
I_{lkg}	Input leakage current	3V applied to pin			100	
R_{IN}	Input impedance	Ground reference	8			MΩ
C_{IN}	Current Sense Input capacitance				10	

(1) See the UCD92xx PMBus Command Reference for the description of the AFE_GAIN field of CLA_GAINS command.

ELECTRICAL CHARACTERISTICS (continued)

PARAMETER		TEST CONDITIONS	MIN	NOM	MAX	UNIT
DIGITAL INPUTS/OUTPUTS						
V_{OL}	Low-level output voltage	$I_{OL} = 6 \text{ mA}^{(2)}$, $V_{V33DIO} = 3 \text{ V}$			Dgnd +0.25	V
V_{OH}	High-level output voltage	$I_{OH} = -6 \text{ mA}^{(3)}$, $V_{V33DIO} = 3 \text{ V}$	V_{33DIO} -0.6V			V
V_{IH}	High-level input voltage	$V_{V33DIO} = 3\text{V}$	2.1		3.6	V
V_{IL}	Low-level input voltage	$V_{V33DIO} = 3.5 \text{ V}$			1.1	V
FAN CONTROL INPUTS/OUTPUTS						
T_{PWM_PERIOD}	FAN-PWM period			156		kHz
$DUTY_{PWM}$	FAN-PWM duty cycle range		0%		100%	
$DUTY_{RES}$	Duty cycle resolution			1%		
$Tach_{RANGE}$	FAN-TACH range	For 1 Tach pulse per revolution. At 2, 3, or 4 pulse/rev, divide by that value	30		300k	RPM
$Tach_{RES}$	FAN-TACH resolution	For 1 Tach pulse per revolution		30		RPM
t_{MIN}	FAN-TACH minimum pulse width	Either positive or negative polarity	150			μs
SYSTEM PERFORMANCE						
V_{Ref}	Setpoint Reference Accuracy	V_{ref} commanded to be 1V, at 25 °C AFEgain = 4, 1V input to EAP/N measured at output of the EADC ⁽⁴⁾	-10		10	mV
	Setpoint Reference Accuracy over temperature	-40 °C to 125 °C	-20		20	mV
$V_{DiffOffset}$	Differential offset between gain settings	AFEgain = 4 compared to AFEgain = 1, 2, or 8	-4		4	mV
t_{Delay}	Digital Compensator Delay ⁽⁵⁾		208 ⁽⁶⁾			ns
F_{SW}	Switching Frequency		15.260		2000	kHz
Duty	Max and Min Duty Cycle	Configured via PMBus	0%		100%	
$V_{DD}Slew$	Minimum V_{DD} slew rate	V_{DD} slew rate between 2.3V and 2.9V	0.25			V/ms
$t_{retention}$	Retention of configuration parameters	$T_J = 25 \text{ °C}$	100			Years
Write_Cycles	Number of nonvolatile erase/write cycles	$T_J = 25 \text{ °C}$	20			K cycles

(2) The maximum I_{OL} , for all outputs combined, should not exceed 12 mA to hold the maximum voltage drop specified.

(3) The maximum I_{OH} , for all outputs combined, should not exceed 48 mA to hold the maximum voltage drop specified.

(4) With default device calibration. PMBus calibration can be used to improve the regulation tolerance.

(5) Time from close of error ADC sample window to time when digitally calculated control effort (duty cycle) is available. This delay must be accounted for when calculating the system dynamic response.

(6) The PMBus command: EADC_SAMPLE_TRIGGER defines the start of the 32ns ADC sample window. So the minimum EAD_SAMPLE_TRIGGER time is $208 + 32 = 240 \text{ ns}$.

ADC MONITORING INTERVALS AND RESPONSE TIMES

The ADC operates in a continuous conversion sequence that measures each rail's output voltage, each power stage's output current, plus four other variables (external temperature, Internal temperature, input voltage and current, and tracking input voltage). The length of the sequence is determined by the number of output rails (NumRails) and total output power stages (NumPhases) configured for use. The time to complete the monitoring sampling sequence is give by the formula:

$$t_{\text{ADC_SEQ}} = t_{\text{ADC}} \times (\text{NumRAILS} + \text{NumPHASE} + 4)$$

PARAMETER		TEST CONDITIONS	MIN	TYP	MAX	UNIT
t_{ADC}	ADC single-sample time			3.84		μs
$t_{\text{ADC_SEQ}}$	ADC sequencer interval	Min = 1 Rail + 1 Phase + 4 = 6 samples Max = 4 Rails + 8 Phases + 4 = 16 samples	23.04		61.44	μs

The most recent ADC conversion results are periodically converted into the proper measurement units (volts, amperes, degrees), and each measurement is compared to its corresponding fault and warning limits. The monitoring operates asynchronously to the ADC, at intervals shown in the table below.

PARAMETER		TEST CONDITIONS	MIN	TYP	MAX	UNIT
t_{Vout}	Output voltage monitoring interval			200		μs
t_{Iout}	Output current monitoring interval			$200 \times N_{\text{Rails}}$		μs
t_{Vin}	Input voltage monitoring interval			2		ms
t_{Iin}	Input current monitoring interval			2		ms
t_{TEMP}	Temperature monitoring interval			800		ms
t_{Ibal}	Output current balancing interval			2		ms
t_{FanTach}	Fan speed monitoring interval			1000		ms

Because the ADC sequencer and the monitoring comparisons are asynchronous to each other, the response time to a fault condition depends on where the event occurs within the monitoring interval and within the ADC sequence interval. Once a fault condition is detected, some additional time is required to determine the correct action based on the FAULT_RESPONSE code, and then to perform the appropriate response. The following table lists the worst-case fault response times.

PARAMETER		TEST CONDITIONS	MAX TIME	UNIT
$t_{\text{OVF}}, t_{\text{UVF}}$	Over/under voltage fault response time during normal operation	Normal regulation, no PMBus activity, 8 stages enabled	300	μs
$t_{\text{OVF}}, t_{\text{UVF}}$	Over/under voltage fault response time, during data logging	During data logging to nonvolatile memory ⁽¹⁾	800	μs
$t_{\text{OVF}}, t_{\text{UVF}}$	Over/under voltage fault response time, when tracking or sequencing enable	During tracking and soft-start ramp.	400	μs
$t_{\text{OCF}}, t_{\text{UCF}}$	Over/under current fault response time during normal operation	Normal regulation, no PMBus activity, 8 stages enabled 75% to 125% current step	⁽²⁾ $100 + (600 \times N_{\text{Rails}})$	μs
$t_{\text{OCF}}, t_{\text{UCF}}$	Over/under current fault response time, during data logging	During data logging to nonvolatile memory 75% to 125% current step	$600 + (600 \times N_{\text{Rails}})$	μs
$t_{\text{OCF}}, t_{\text{UCF}}$	Over/under current fault response time, when tracking or sequencing enable	During tracking and soft start ramp 75% to 125% current step	$300 + (600 \times N_{\text{Rails}})$	μs
t_{OTF}	Overtemperature fault response time	Temperature rise of 10 °C/sec, OT threshold = 100 °C	5	s

- (1) During a STORE_DEFAULT_ALL command, which stores the entire configuration to nonvolatile memory, the fault detection latency can be up to 10 ms.
- (2) Because the current measurement is averaged with a smoothing filter, the response time to an Overcurrent condition depends on a combination of the time constant (τ) from Table 4, the recent measurement history, and how much the measured value exceeds the overcurrent limit.

HARDWARE FAULT DETECTION LATENCY

The controller contains hardware fault detection circuits that are independent of the ADC monitoring sequencer.

PARAMETER		TEST CONDITIONS	MAX TIME	UNIT
t_{FAULT}	Time to disable DPWM output base on active FAULT pin signal	High level on FAULT pin	$15 + 3 \times \text{NumPhases}$	μs
$t_{\text{CLF-A}}$	Time to disable the DPWM A output based on internal analog comparator	Step change in CS voltage from 0v to 2.5V	4	Switch Cycles
$t_{\text{CLF-B}}$	Time to disable all remaining DPWM and SRE outputs configured to drive a voltage rail after a CLF-A event occurs	Step change in CS voltage from 0V to 2.5V	$10 + 3 \times \text{NumPhases}$	μs

PMBUS/SMBUS/I²C

The timing characteristics and timing diagram for the communications interface that supports I²C, SMBus and PMBus are shown below.

I²C/SMBus/PMBus Timing Characteristics

$T_A = -40^\circ\text{C}$ to 85°C , $3\text{V} < V_{\text{DD}} < 3.6\text{V}$, typical values at $T_A = 25^\circ\text{C}$ and $V_{\text{CC}} = 2.5\text{V}$ (Unless otherwise noted)

PARAMETER		TEST CONDITIONS	MIN	TYP	MAX	UNIT
f_{SMB}	SMBus/PMBus operating frequency	Slave mode; SMBC 50% duty cycle	10		1000	kHz
f_{I2C}	I ² C operating frequency	Slave mode; SCL 50% duty cycle	10		1000	kHz
$t_{\text{(BUF)}}$	Bus free time between start and stop		4.7			μs
$t_{\text{(HD:STA)}}$	Hold time after (repeated) start		0.26			μs
$t_{\text{(SU:STA)}}$	Repeated start setup timed		0.26			μs
$t_{\text{(SU:STO)}}$	Stop setup time		0.26			μs
$t_{\text{(HD:DAT)}}$	Data hold time	Receive mode	0			ns
$t_{\text{(SU:DAT)}}$	Data setup time		50			ns
$t_{\text{(TIMEOUT)}}$	Error signal/detect	See ⁽¹⁾			35	μs
$t_{\text{(LOW)}}$	Clock low period		0.5			μs
$t_{\text{(HIGH)}}$	Clock high period	See ⁽²⁾	0.26		50	μs
$t_{\text{(LOW:SEXT)}}$	Cumulative clock low slave extend time	See ⁽³⁾			25	μs
t_{FALL}	Clock/data fall time	See ⁽⁴⁾			120	ns
t_{RISE}	Clock/data rise time	See ⁽⁵⁾			120	ns

(1) The UCD9240 times out when any clock low exceeds $t_{\text{(TIMEOUT)}}$.

(2) $t_{\text{(HIGH), max}}$, is the minimum bus idle time. SMBC = SMBD = 1 for $t > 50\text{ms}$ causes reset of any transaction involving UCD9240 that is in progress. This specification is valid when the NC_SMB control bit remains in the default cleared state (CLK[0]=0).

(3) $t_{\text{(LOW:SEXT)}}$ is the cumulative time a slave device is allowed to extend the clock cycles in one message from initial start to the stop.

(4) Rise time $t_{\text{RISE}} = V_{\text{VILMAX}} - 0.15$ to $(V_{\text{VIHMIN}} + 0.15)$

(5) Fall time $t_{\text{FALL}} = 0.9 V_{\text{DD}}$ to $(V_{\text{ILMAX}} - 0.15)$

The coefficients of the filter sections are generated through modeling the power stage and load in the Power+ Designer tool. Several banks of filter coefficients can be downloaded to the device that can automatically switch them based on the power stage operation.

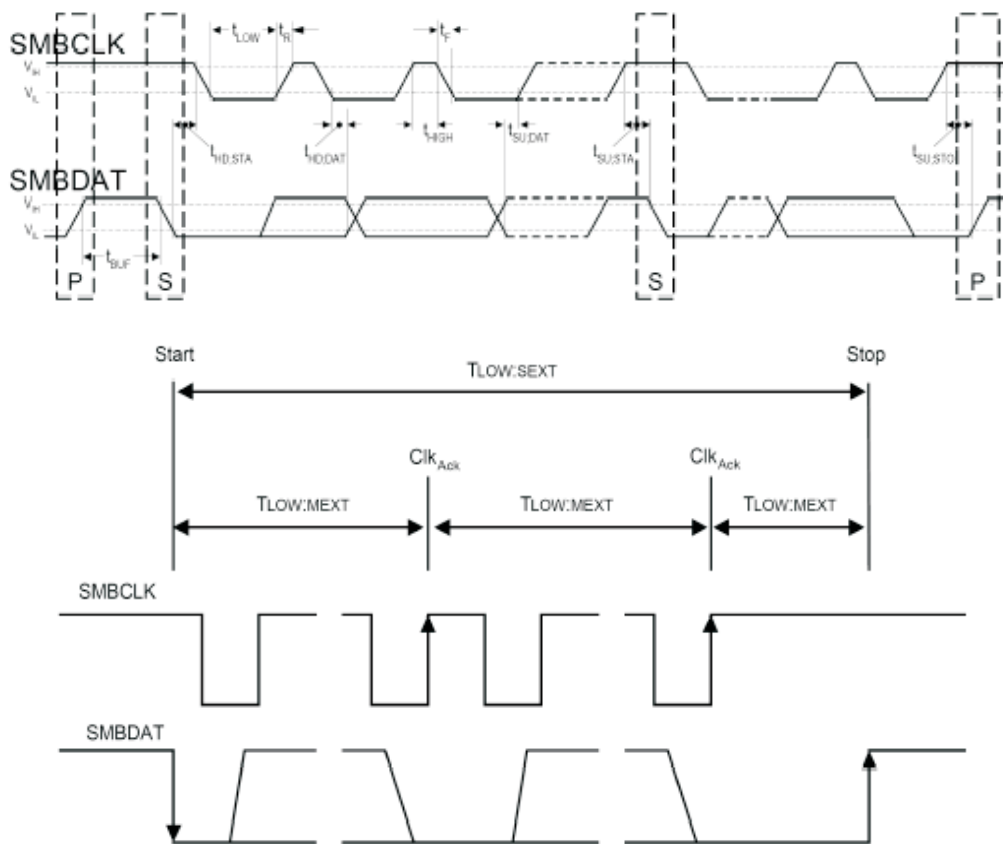
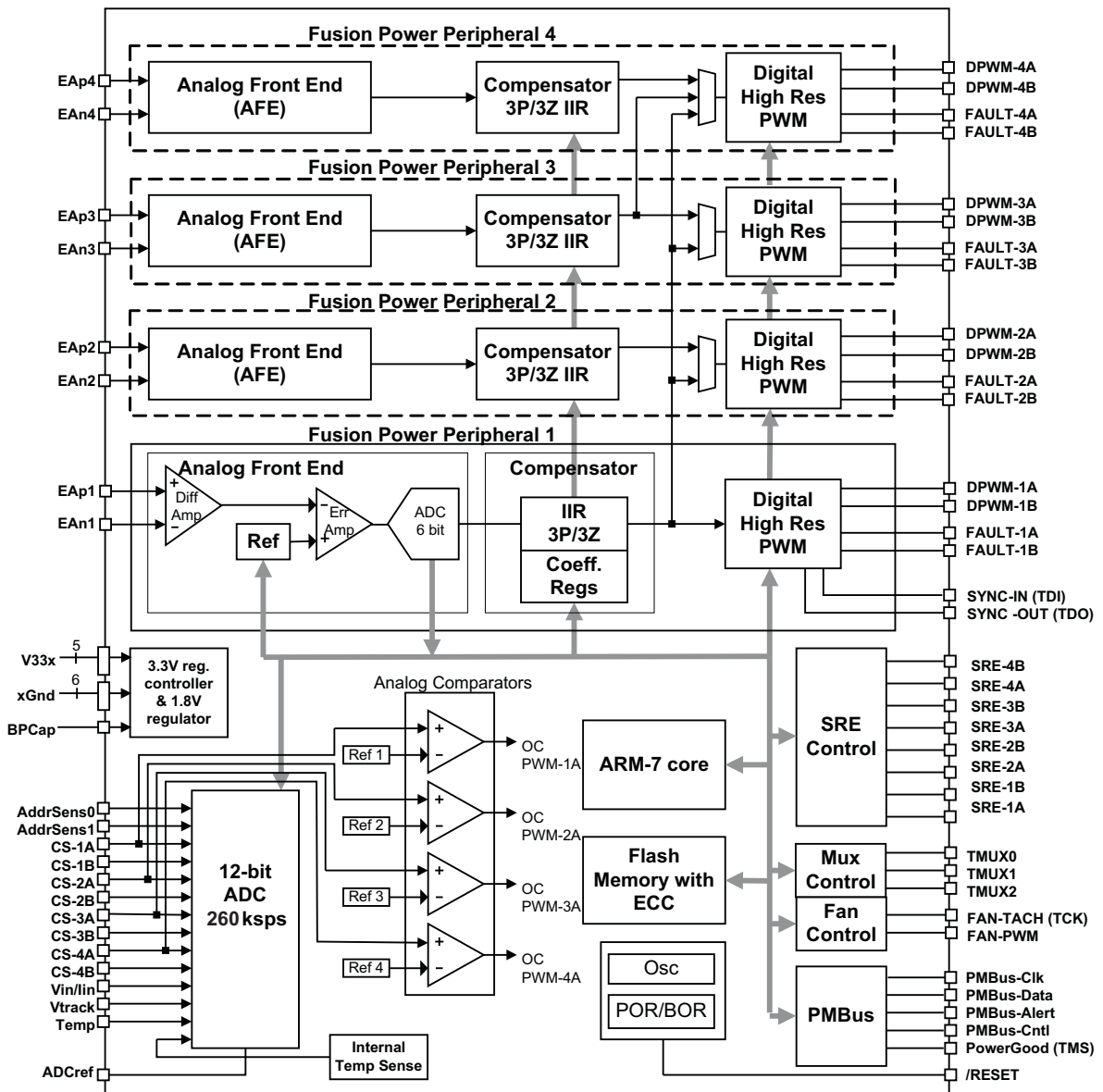

Figure 1. I²C/SMBus/PMBus Timing in Extended Mode Diagram

FUNCTIONAL BLOCK DIAGRAM



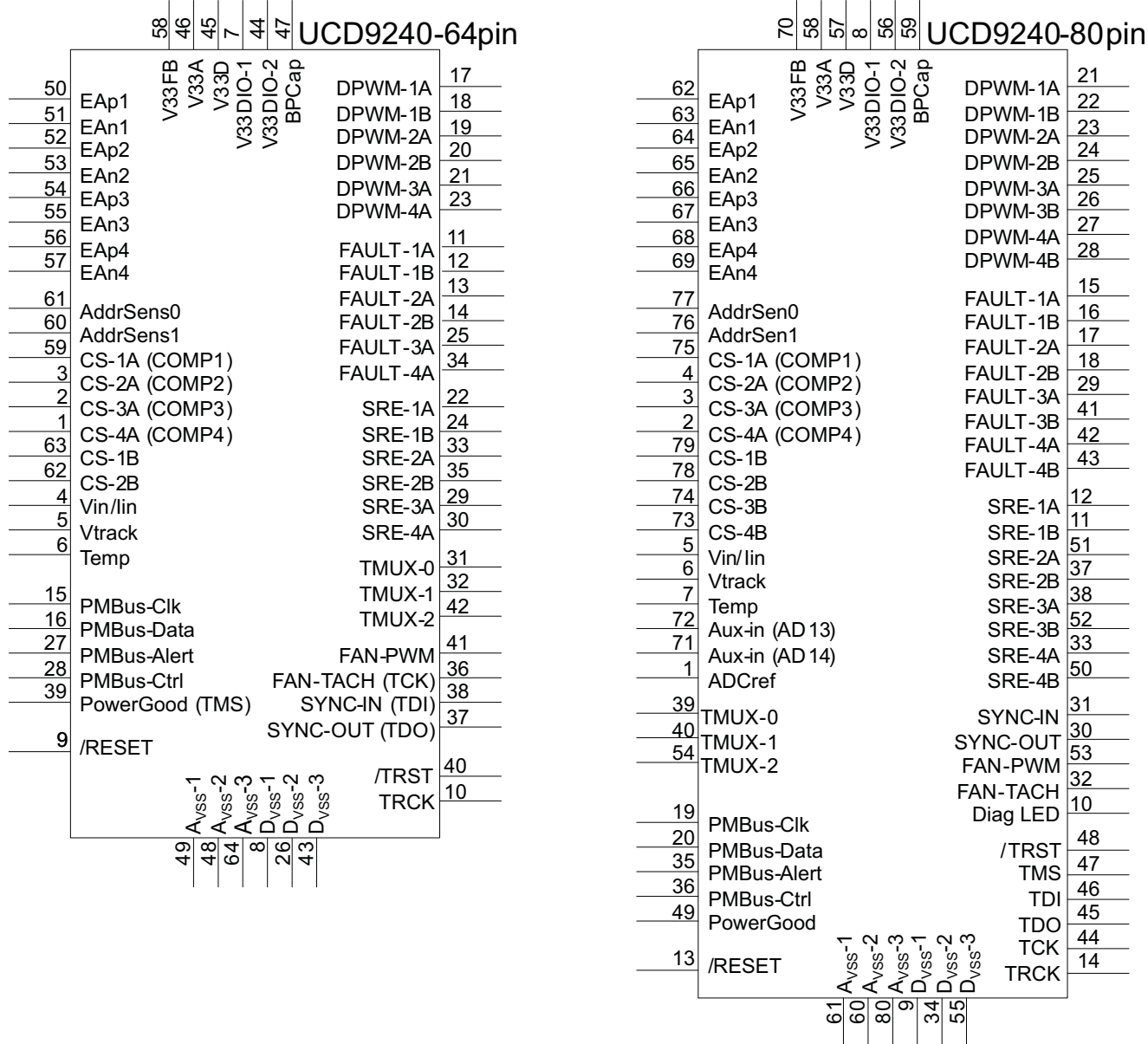

Figure 2. UCD9240 Pin Assignment

The UCD9240 is available in a plastic 64-pin QFN package (RGC) and an 80-pin TQFP package (PFC).

TYPICAL APPLICATION SCHEMATIC

Figure 3 shows the UCD9240 power supply controller as part of a system that provides the regulation of four independent power supplies. The loop for each power supply is created by the respective voltage outputs feeding into the differential voltage error ADC (EADC) inputs, and completed by DPWM outputs feeding into the gate drivers for each power stage.

The $\pm V_{sense}$ rail signals must be routed to the EAp/EAn input that matches the number of the lowest DPWM configured as part of the rail. (See more detail on page 19, "Flexible Rail/Power Stage Configuration".)

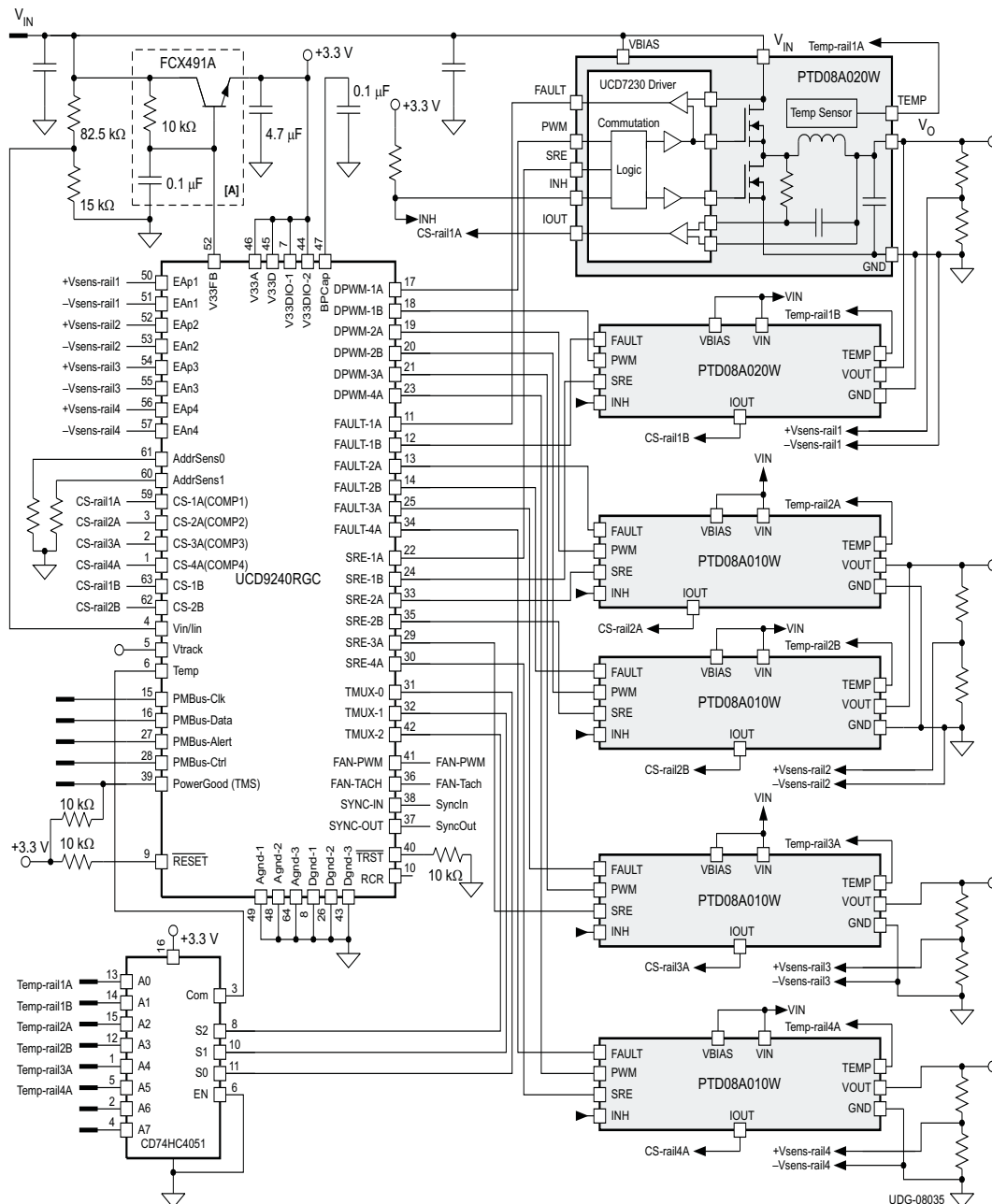

Figure 3. Typical Application Schematic

PIN DESCRIPTIONS

64-PIN PACKAGE		80-PIN PACKAGE		I/O	DESCRIPTION
PIN NO.	SIGNAL	PIN NO.	SIGNAL		
Error Amplifier Differential Analog Inputs					
50	EAp1	62	EAp1	AI	Error analog, differential voltage. Positive channel #1 input.
51	EAn1	63	EAn1	AI	Error analog, differential voltage. Negative channel #1 input.
52	EAp2	64	EAp2	AI	Error analog, differential voltage. Positive channel #2 input.
53	EAn2	65	EAn2	AI	Error analog, differential voltage. Negative channel #2 input.
54	EAp3	66	EAp3	AI	Error analog, differential voltage. Positive channel #3 input.
55	EAn3	67	EAn3	AI	Error analog, differential voltage. Negative channel #3 input.
56	EAp4	68	EAp4	AI	Error analog, differential voltage. Positive channel #4 input.
57	EAn4	69	EAn4	AI	Error analog, differential voltage. Negative channel #4 input.
Analog Inputs					
61	AddrSens0	77	AddrSens0	AI	PMBus address sense. Least significant address bits
60	AddrSens1	76	AddrSens1	AI	PMBus address sense. Most significant address bits
59	CS-1A	75	CS-1A	AI	Power stage 1A current sense input. Analog comparator 1
3	CS-2A	4	CS-2A	AI	Power stage 2A current sense input. Analog comparator 2
2	CS-3A	3	CS-3A	AI	Power stage 3A current sense input. Analog comparator 3
1	CS-4A	2	CS-4A	AI	Power stage 4A current sense input. Analog comparator 4
63	CS-1B	79	CS-1B	AI	Power stage 1B current sense input
62	CS-2B	78	CS-2B	AI	Power stage 2B current sense input
–	CS-3B	74	CS-3B	AI	Power stage 3B current sense input
–	CS-4B	73	CS-4B	AI	Power stage 4B current sense input
4	V _{in} / I _{in}	5	V _{in} / I _{in}	AI	Input supply sense, alternates between V _{in} and I _{in}
5	VTRACK	6	VTRACK	AI	Voltage tracking
6	Temp	7	Temp	AI	Temperature sense input
–	Aux-in (AD13)	72	Aux-in (AD13)	AI	Unused analog input -- Tie to ground with 10 kΩ resistor
–	Aux-in (AD14)	71	Aux-in (AD14)	AI	Unused analog input -- Tie to ground with 10 kΩ resistor
–	ADCref	1	ADCref	AI	ADC Decoupling Capacitor -- Tie 0.1 μF cap to ground
Digital PWM Outputs					
17	dPWM-1A	21	dPWM-1A	O	DPWM 1A output
18	dPWM-1B	22	dPWM-1B	O	DPWM 1B output
19	dPWM-2A	23	dPWM-2A	O	DPWM 2A output
20	dPWM-2B	24	dPWM-2B	O	DPWM 2B output
21	dPWM-3A	25	dPWM-3A	O	DPWM 3A output
		26	dPWM-3B	O	DPWM 3B output
23	dPWM-4A	27	dPWM-4A	O	DPWM 4A output
		28	dPWM-4B	O	DPWM 4B output
External Fault Inputs					
11	FAULT-1A	15	FAULT-1A	I	External fault input 1A
12	FAULT-1B	16	FAULT-1B	I	External fault input 1B
13	FAULT-2A	17	FAULT-2A	I	External fault input 2A
14	FAULT-2B	18	FAULT-2B	I	External fault input 2B
25	FAULT-3A	29	FAULT-3A	I	External fault input 3A
		41	FAULT-3B	I	External fault input 3B
34	FAULT-4A	42	FAULT-4A	I	External fault input 4A
		43	FAULT-4B	I	External fault input 4B

PIN DESCRIPTIONS (continued)

64-PIN PACKAGE		80-PIN PACKAGE		I/O	DESCRIPTION
PIN NO.	SIGNAL	PIN NO.	SIGNAL		
Synchronous Rectification Enable Outputs					
22	SRE-1A	12	SRE-1A	O	Synchronous rectifier enable 1A
24	SRE-1B	11	SRE-1B	O	Synchronous rectifier enable 1B
33	SRE-2A	51	SRE-2A	O	Synchronous rectifier enable 2A
35	SRE-2B	37	SRE-2B	O	Synchronous rectifier enable 2B
29	SRE-3A	38	SRE-3A	O	Synchronous rectifier enable 3A
		52	SRE-3B	O	Synchronous rectifier enable 3B
30	SRE-4A	33	SRE-4A	O	Synchronous rectifier enable 4A
		50	SRE-4B	O	Synchronous rectifier enable 4B
Miscellaneous Digital I/O					
31	TMUX-0	39	TMUX-0	O	Temperature multiplexer select S0
9	RESET	13	RESET	I	Active low device reset input
32	TMUX-1	40	TMUX-1	O	Temperature multiplexer select S1
42	TMUX-2	54	TMUX-2	O	Temperature multiplexer select S2
41	FAN-PWM	53	FAN-PWM	O	Fan control PWM output
39	PowerGood	49	PowerGood	O	Power good signal (multiplexed with TMS on 64-pin package)
36	FAN-Tach	32	FAN-Tach	I	Fan tachometer input (multiplexed with TCK on 64-pin package)
37	Sync_Out	30	Sync_Out	O	Synchronization output from DPWM (multiplexed with TDO on 64-pin package)
38	Sync_In	31	Sync_In	I	Synchronization input to DPWM (multiplexed with TDI on 64-pin package)
		10	diag LED	O	Diagnostic LED
PMBus Communications Interface					
15	PMBus_Clk	19	PMBus_Clk	I/O	PMBus Clk (Must have pullup to 3.3 V)
16	PMBus_Data	20	PMBus_Data	I/O	PMBus Data (Must have pullup to 3.3 V)
27	PMBus_Alert	35	PMBus_Alert	O	PMBUS Alert
28	PMBus_Cntrl	36	PMBus_Cntrl	I	PMBUS Cntrl
JTAG					
10	TRCK	14	TRCK	O	Test return clock
36	TCK	44	TCK	I	Test clock (multiplexed with FAN-Tach (TCK) on 64-pin package)
37	TDO	45	TDO	O	Test data out (multiplexed with Sync_Out (TDO) on 64-pin package)
38	TDI	46	TDI	I	Test data in -- tie to Vdd with 10 kΩ resistor (multiplexed with Sync_In (TDI) on 64-pin package)
39	TMS	47	TMS	I/O	Test mode select -- tie to Vdd with 10 kΩ resistor (multiplexed with PowerGood (TMS) on 64-pin package)
40	TRST	48	TRST	I/O	Test reset -- tie to ground with 10 kΩ resistor
Input Power and Grounds					
58	V33FB	70	V33FB	O	3.3-V linear regulator Feedback connection
46	V33A	58	V33A	I	Analog 3.3-V supply
45	V33D	57	V33D	I	Digital core 3.3-V supply
7	V33DIO	8	V33DIO	I	Digital I/O 3.3-V supply
44	V33DIO	56	V33DIO	I	Digital I/O 3.3-V supply
47	BPCap	59	BPCap	I	1.8-V bypass capacitor connection
49	AV _{SS}	61	AV _{SS}	I	Analog ground
48	AV _{SS}	60	AV _{SS}	I	Analog ground
64	AV _{SS}	80	AV _{SS}	I	Analog ground

PIN DESCRIPTIONS (continued)

64-PIN PACKAGE		80-PIN PACKAGE		I/O	DESCRIPTION
PIN NO.	SIGNAL	PIN NO.	SIGNAL		
8	DV _{SS}	9	DV _{SS}	I	Digital ground
26	DV _{SS}	34	DV _{SS}	I	Digital ground
43	DV _{SS}	55	DV _{SS}	I	Digital ground
Power Pad	No Connect	n/a	n/a	I	It is recommended that this pad be connected to analog ground. (64-pin package only)

FUNCTIONAL OVERVIEW

The UCD9240 contains four fusion power peripherals (FPP). Each FPP can be configured to regulated up to four DC/DC converter outputs. There are eight PWM outputs that can be assigned to drive the coverter outputs. Each FPP can be configured to drive from one of the eight power stages. Each FPP consists of:

- A differential input error voltage amplifier.
- A 10-bit DAC used to set the output regulation reference voltage.
- A fast ADC with programmable input gain to digitally measure the error voltage.
- A dedicated 3-pole/3-zero digital filter to compensate the error voltage.
- A digital PWM (DPWM) engine that generates the PWM pulse width based on the compensator output.

Each controller is configured through a PMBus serial interface.

PMBus Interface

The PMBus is a serial interface specifically designed to support power management. It is based on the SMBus interface that is built on the I²C physical specification. The UCD9240 supports revision 1.1 of the PMBus standard. Wherever possible, standard PMBus commands are used to support the function of the device. For unique features of the UCD9240, MFR_SPECIFIC commands are defined to configure or activate those features. These commands are defined in the *UCD92xx PMBUS Command Reference*.

The UCD9240 is PMBus compliant, in accordance with the "Compliance" section of the PMBus specification. The firmware is also compliant with the SMBus 1.1 specification, including support for the SMBus ALERT function. The hardware can support either 100 kHz, 400 kHz, or 1 MHz PMBus operation.

Resistor Programmed PMBus Address Decode

Two pins are allocated to decode the PMBus address. At power-up, the device applies a bias current to each address detect pin, and the voltage on that pin is captured by the internal 12-bit ADC. The PMBus address is calculated as follows:

$$\text{PMBus Address} = 12 \times \text{bin}(V_{AD01}) + \text{bin}(V_{AD00})$$

Where $\text{bin}(V_{AD0x})$ is the address bin for one of 12 address as shown in [Table 1](#).

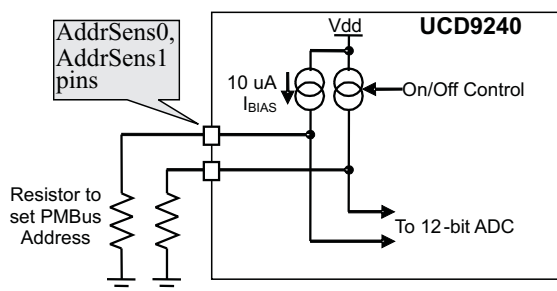

Figure 4. PMBus Address Detection Method

The address bins are defined so that each bin is a constant ratio of the previous bin. This method maintains the width of each bin relative to the tolerance of the standard 1% resistors. The ratio between bins is 1.30.

Table 1. PMBus Address Bins

PMBus ADDRESS	V_{PMBus} PMBus VOLTAGE RANGE (V)		R_{PMBus} PMBus RESISTANCE (k Ω)
	MIN	MAX	
open	2.226	3.300	–
11	1.746	2.255	210
10	1.342	1.746	158
9	1.030	1.341	115
8	0.792	1.030	84.5
7	0.609	0.792	63.4
6	0.468	0.608	47.5
5	0.359	0.467	36.5
4	0.276	0.358	27.4
3	0.212	0.275	21.5
2	0.162	0.211	16.9
1	0.125	0.162	13.0
0	0.098	0.124	10.2
short	0	0.097	–

A low impedance (short) on either address pin that produces a voltage below the minimum voltage causes the PMBus address to default to address 126. A high impedance (open) on either address pin that produces a voltage above the maximum voltage also causes the PMBus address to default to address 126.

The PMBus address can be set to any value ranging from 1 to 126, except address 12. Address 0 is not used because it is the SMBus General Call address; address 12 is reserved for the PMBus alert response. Also, it is recommended that address 11 not be used by this device or any other device that shares the PMBus with it, since it is used in manufacturing to program the device. Further, address 127 cannot be used by this device or any other device that shares the PMBus with it, since the address is reserved by this device for device manufacturing test.

Finally, it is recommended that address 126 not be used for any devices on the PMBus, since this is the address that the UCD9240 defaults to if the address lines are shorted to ground or left open. If any other UCD9240 has a short or open on its address lines, then its address would conflict with the (programmed) address 126.

External Reset

The device can be forced into the reset state by an external circuit connected to the $\overline{\text{RESET}}$ pin. A logic low voltage on this pin holds the device in reset. To avoid an erroneous trigger caused by noise, a pull up resistor to 3.3V is recommended.

Output Voltage Adjustment

The nominal output voltage is programmed by a combination of PMBus commands: VOUT_COMMAND, VOUT_CAL_OFFSET, and VOUT_MAX. Their relationship is shown in Figure 6. Output voltage margining is configured by the VOUT_MARGIN_HIGH and VOUT_MARGIN_LOW commands. The OPERATION command selects between the nominal output voltage and either of the margin voltages. The OPERATION command also includes an option to suppress certain voltage faults and warnings while operating at the margin settings.

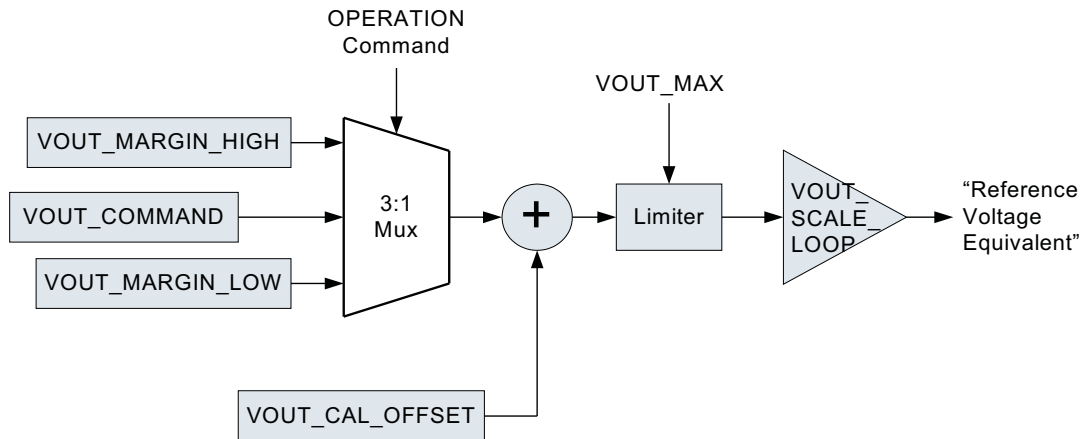

Figure 6. PMBus Voltage Adjustment Methods

For a complete description of the commands supported by the UCD9240 see the UCD92xx PMBUS Command Reference. Each of these commands can also be issued from the Texas Instruments Fusion Digital Power™ Designer program. This Graphical User Interface (GUI) PC program issues the appropriate commands to configure the UCD9240 device.

Analog Front End (AFE)

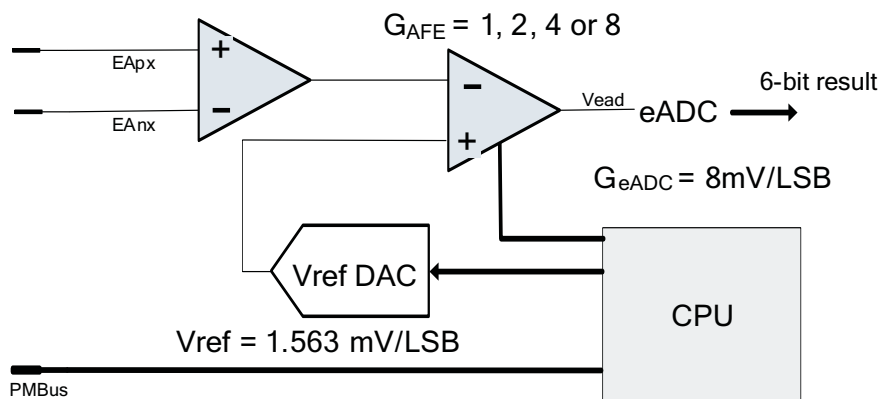

Figure 7. Analog Front End Block Diagram

The UCD9240 senses the power supply output voltage differentially through the EAP and EAN pins. The error amplifier utilizes a switched capacitor topology that provides a wide common mode range for the output voltage sense signals. The fully differential nature of the error amplifier also ensures low offset performance.

The output voltage is sampled at a programmable time (set by the EADC_SAMPLE_TRIGGER PMBus

command). When the differential input voltage is sampled, the voltage is captured in internal capacitors and then transferred to the error amplifier where the value is subtracted from the set-point reference which is generated by the Vref DAC as shown in Figure 7. The resulting error voltage is then amplified by a programmable gain circuit before the error voltage is converted to a digital value by the flash ADC. This programmable gain is configured through the PMBus and affects the dynamic range and resolution of the sensed error voltage as shown in Table 3.

Table 3. Analog Front End Resolution

AFE GAIN	AFE_GAIN for PMBus COMMAND	EFFECTIVE ADC RESOLUTION (mV)	DIGITAL ERROR VOLTAGE DYNAMIC RANGE (mV)
1	0	8	-256 to 248
2	1	4	-128 to 124
4	2	2	-64 to 62
8	3	1	-32 to 31

The AFE variable gain is one of the compensation coefficients that are stored when the device is configured by issuing the CLA_GAINS PMBus command. Compensator coefficients are arranged in several banks: one bank for start/stop ramp or tracking, one bank for normal regulation mode and one bank for light load mode. This allows the user to trade-off resolution and dynamic range for each operational mode.

The EADC, which samples the error voltage, has high accuracy, high resolution, and a fast conversion time. However, its range is limited as shown in Table 3. If the output voltage is different from the reference by more than this, the EADC reports a saturated value at -32 LSBs or 31 LSBs. The UCD9240 overcomes this limitation by adjusting the setpoint DAC up or down in order to bring the error voltage out of saturation. In this way, the effective range of the ADC is extended. When the EADC saturates, the setpoint DAC is slewed at a rate of 0.156 V/ms, referred to the EA differential inputs.

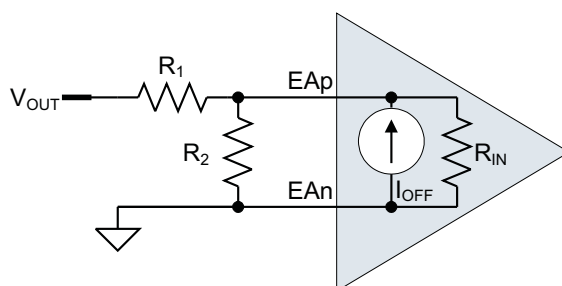

Figure 8. Input Offset Equivalent Circuit

To obtain the best possible accuracy, the input resistance and offset current on the device should be considered when calculating the gain of a voltage divider between the output voltage and the EA sense inputs of the UCD9240. The input resistance and input offset current are specified in the parametric tables in this datasheet.

$$V_{EA} = \frac{R_2}{R_1 + R_2 + \left(\frac{R_1 R_2}{R_{IN}}\right)} V_{OUT} + \frac{R_1 R_2}{R_1 + R_2 + \left(\frac{R_1 R_2}{R_{IN}}\right)} I_{OFF}$$

The effect of the offset current can be reduced by making the resistance of the divider network low. R1 should be between 1kΩ and 5kΩ. Then R2, the lower divider resistor, can be calculated as:

$$R_2 = \frac{R_1 V_{EA}}{V_{OUT} - \left(1 + \frac{R_1}{R_{IN}}\right) V_{EA} \pm R_1 I_{OFF}}$$

Digital Compensator

Each voltage rail controller in the UCD9240 includes a digital compensator. The compensator consists of a nonlinear gain stage, followed by a digital filter consisting of a second order infinite impulse response (IIR) filter section cascaded with a first order IIR filter section.

The Texas Instruments Fusion Digital Power™ Designer development tool can be used to assist in defining the compensator coefficients. The design tool allows the compensator to be described in terms of the pole frequencies, zero frequencies and gain desired for the control loop. In addition, the Fusion Digital Power™ Designer can be used to characterize the power stage so that the compensator coefficients can be chosen based on the total loop gain for each feedback system. The coefficients of the filter sections are generated through modeling the power stage and load.

Additionally, the UCD9240 has three banks of filter coefficients: Bank-0 is used during the soft start/stop ramp or tracking; Bank-1 is used while in regulation mode; and Bank-2 is used when the measured output current is below the configured light load threshold.

The compensator also allows the minimum and maximum duty cycle to be programmed. This again is done by issuing a PMBus command to the device.

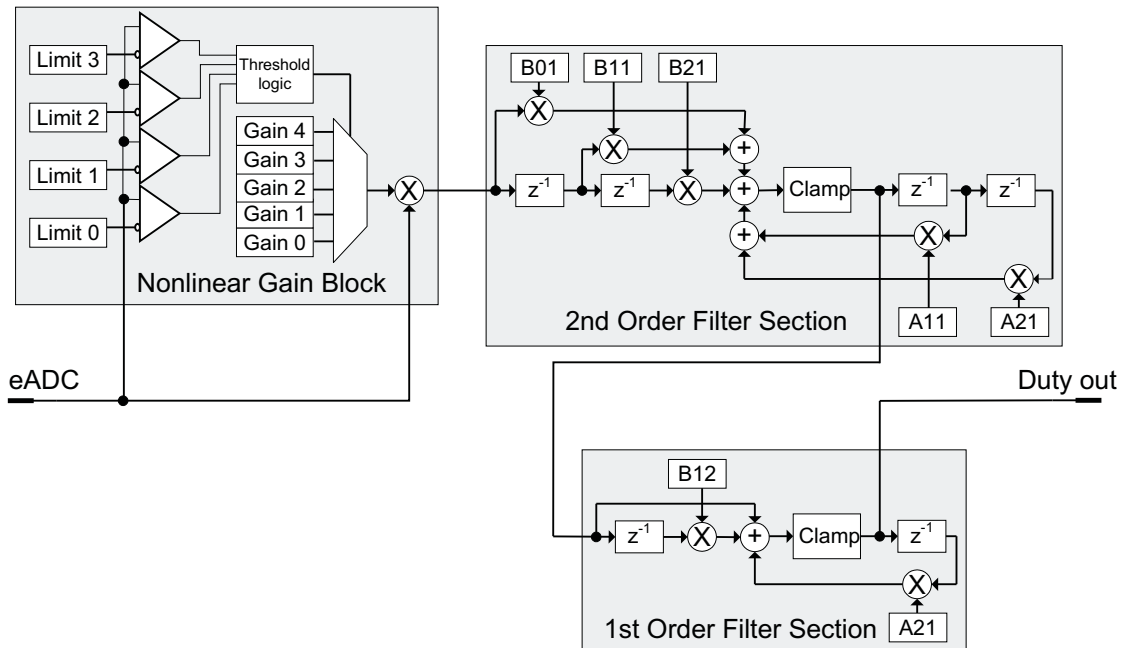

Figure 9. Digital Compensator

The nonlinear gain block allows a different gain to be applied to the system when the error voltage deviates from zero. Typically Limit 0 and Limit 1 would be configured with negative values between -1 and -32 and Limit 2 and Limit 3 would be configured with positive values between 1 and 31. However, the gain thresholds do not have to be symmetric. For example, the four limit registers could all be set to positive values causing the Gain 0 value to set the gain for all negative errors and a nonlinear gain profile would be applied to only positive error voltages.

The cascaded 1st order filter section is used to generate the third zero and third pole.

DPWM Engine

The output of the compensator feeds the high resolution DPWM engine. The DPWM engine produces the pulse width modulated gate drive output from the device. In operation, the compensator calculates the necessary duty cycle as a digital number representing a value from 0 to 1. This duty cycle value is multiplied by the configured period to generate a comparator threshold value. This threshold is compared against the high speed switching period counter to generate the desired DPWM pulse width. This is shown in [Figure 10](#). The resolution of the duty period is nominally 250 picoseconds.

Each DPWM engine can be synchronized to another DPWM engine or to an external sync signal via the SYNC_IN and SYNC_OUT pins. Configuration of the synchronization function is done through a MFR_SPECIFIC PMBus command. See the DPWM Synchronization section for more details.

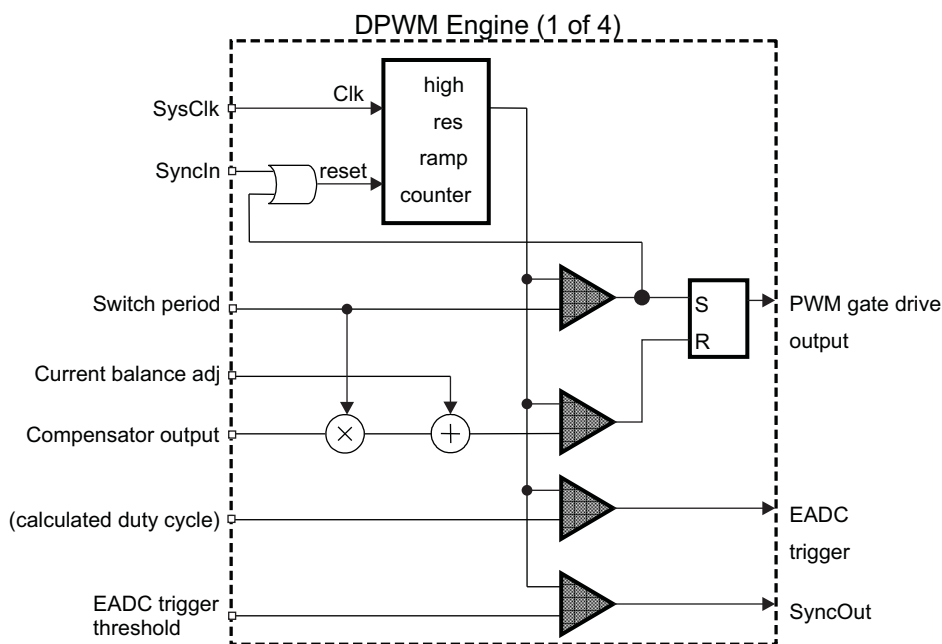

Figure 10. DPWM Engine

The switching frequency is set by issuing the FREQUENCY_SWITCH PMBus command.

Flexible Rail/Power Stage Configuration

The UCD9240 can control up to four rails, each of which can comprise a programmable number of power stages. Constraints on the mapping of power stages to rails are described in detail in the UCD92xx PMBus Command Reference under the PHASE_INFO command.

While there is significant flexibility in terms of mapping power stages to output rails, the differential voltage feedback signals (EAP/EAN) cannot be re-mapped through any commands, and therefore, must be connected to the proper input on the circuit board. Because the EADC sample trigger for a given front end stage is derived from the ramp timer of the first (lowest numbered) DPWM on the rail, the system must ensure that the number of the EADC and the number of the first DPWM match. For example, consider a two rail configuration in which 4 power stages (1A, 2A, 1B and 2B) are assigned to the first rail and 2 power stages (3A and 4A) to the second. The first DPWM on the first rail is 1; its voltage feedback must be through EAP1/EAN1. The first DPWM on the second rail is 3; its voltage feedback must be through EAP3/EAN3. (In this configuration EAP2/EAN2 and EAP4/EAN4 are unused and are disabled to reduce unnecessary power consumption.)

DPWM Phase Distribution

The number of voltage rails is configured using the PHASE_INFO PMBus command. The UCD9240 automatically synchronizes the first power stage of each voltage rail. The phase (in time) of each 1st power stage is shifted by an amount in order to minimize input current ripple. The amount that each 1st power stage is shifted is:

$$t_{\text{rail-rail spread}} = \frac{3}{13} t_{\text{SW}}$$

Where t_{SW} is the period of the rail with the fastest switching frequency.

The ratio 3/13 is chosen because it is close to 1/4, but it is a prime ratio. This should ensure that any configuration of rails and power stages should not have the leading edge of the DPWM signal aligned.

The PHASE_INFO PMBus command is also used to configure the number of power stages driving each voltage rail. When multiple power stages are configured to drive a voltage rail, the UCD9240 automatically distributes the phase of each DPWM output to minimize ripple. This is accomplished by setting the rising edge of each DPWM pulse to be separated by:

$$t_{\text{phase-phase spread}} = \frac{t_{\text{SW}}}{N_{\text{Phases}}}$$

Where t_{SW} is the switching period and N_{Phases} is the number of power stages driving a voltage rail.

DPWM Synchronization

DPWM synchronization provides a method to link the timing between rails on two distinct devices at the switching rate; i.e., two rails on different devices can be configured to run at the same frequency and sync forcing them not to drift from each other. (Note that within a single device, because all rails are driven off a common clock there is no need for an internal sync because rails won't drift.)

The PMBus SYNC_IN_OUT command sets which rails (if any) should follow the sync input, and which rail (if any) should drive the sync output.

For rails that are following the sync input, the DPWM ramp timer for that output is reset when the sync input goes high. This allows the slave device to sync to inputs that are either faster or slower than it is. On the fast side, there is no limit to how much faster the input is compared to the defined frequency of the rail; when the pulse comes in, the timer is reset and the frequencies are locked. This is the standard mode of operation - setting the slave to run slower, and letting the sync speed it up.

If the slave rail is running fast, the sync pulse resets the counter after the DPWM output has already been turned on. Resetting the counter at this point results in a larger duty cycle for that period. Because the system is closed loop; however, the controller reacts by decreasing the commanded control effort, with the result being a regulated rail synchronized to a slower master. Synchronizing to the slower master does have a limit however. If the master is slow enough that the DPWM output has sufficient time to output the entire command pulse before the sync input arrives, the result is a double pulse. This is likely an undesirable mode of operation.

The Sync Input and Output Configuration Word set by the PMBus command consists of two bytes. The upper byte (sync_out) controls which rail drives the sync output signal (0=DPWM1, 1=DPWM2, 2=DPWM3, 3=DPWM4. Any other value disables sync_out). The lower byte (sync_in) determines which rail(s) respond to the sync input signal (each bit represents one rail - note that multiple rails can be synchronized to the input). The DPWM period is aligned to the sync input. For more information, see the UCD92xx PMBUS Command Reference.

Note that once a rail is synchronized to an external source, the rail-to-rail spacing that attempts to minimize input current ripple are lost. Rail-to-rail spacing can only be restored by power cycling or issuing a SOFT_RESET command.

Phase Shedding at Light Current Load

By issuing LIGHT_LOAD_LIMIT_LOW, LIGHT_LOAD_LIMIT_HIGH, and LIGHT_LOAD_CONFIG commands, the UCD9240 can be configured to shed (disable) power stages when at light load. When this feature is enabled, the device disables the configured number of power stages when the average current drops below the specified LIGHT_LOAD_LIMIT_LOW. In addition, a separate set of compensation coefficients can be loaded into the digital compensator when entering a light load condition.

Phase Adding at Normal Current Load

After shedding phases, if the current load is increased past the LIGHT_LOAD_LIMIT_HIGH threshold, all phases are re-enabled. If the compensator was configured for light load, the normal load coefficients are restored as well. See the UCD92xx PMBUS Command Reference for more information.

Output Current Measurement

Pins CS-1A, CS-1B, CS-2A, CS-2B, CS-3A, CS-3B, CS-4A, and CS-4B are used to measure either output current or inductor current in each of the controlled power stages. PMBus commands IOUT_CAL_GAIN and IOUT_CAL_OFFSET are used to calibrate each measurement. See the UCD92xx PMBus Command Reference for specifics on configuring this voltage to current conversion.

When the measured current is outside the range of either the overcurrent or undercurrent threshold, a FAULT is

declared and the UCD9240 performs the PMBus configured fault recovery. ADC current measurements are digitally averaged before they are compared against the FAULT threshold. The output current is measured at a rate of one output rail per 200 microseconds. The current measurements are then passed through a smoothing filter to reduce noise on the signal and prevent false errors. The output of the smoothing filter asymptotically approaches the input value with a time constant that is approximately 3.5 times the sampling interval.

Table 4. Output Current Filter Times Constants

NUMBER OF OUTPUT RAILS	OUTPUT CURRENT SAMPLING INTERVALS (μs)	FILTER TIME CONSTANTS (ms)
1	200	0.7
2	400	1.4
3	600	2.1
4	800	2.8

For example, with a single rail, the filter has the transfer function characteristics (Figure 11) that shows the signal magnitude at the output of the averaging filter due to a sine wave input for a range of frequencies. This plot includes an RC analog low pass network, with a corner frequency of 3 kHz, on the current sense inputs.

This averaged current measurement is used for output current fault detection; see “Overcurrent Detection,” below.

In response to a PMBus request for a current reading, the device returns an average current value. When the UCD9240 is configured to drive a multi-phase power converter, the device adds the average current measurement for each of the power stages tied to a power rail.

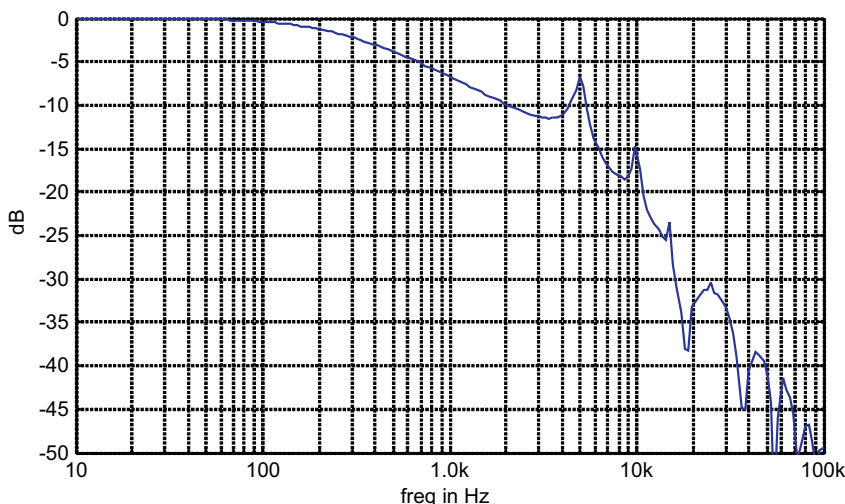

Figure 11. Averaging Filter for Current Monitoring

Output Current Balancing

When the UCD9240 is configured to drive multiple power stage circuits from one compensator, current balancing is implemented by adjusting each gate drive output pulse width to correct for current imbalance between the connected power stage sections. The UCD9240 balances the current by monitoring the current at the CS analog input for each power stage and then adding a current balance adjustment value to the DPWM ramp threshold value for each power stage.

When there is more than one power stage connected to the voltage rail, the device continually determines which stage has the highest measured current and which stage has the lowest measured current. To balance the currents while maintaining a constant total current, the adjustment value for the power stage with the lowest current is increased by the same amount as the adjustment value for the power stage with the highest current is decreased. A slight modification to this algorithm is made to keep the adjustment values positive in order to ensure that a positive DPWM duty cycle is commanded under all conditions.

Overcurrent Detection

Several mechanisms are provided to sense output current fault conditions. This allows for the design of power systems with multiple layers of protection.

1. A logic high signal on the FAULT input causes a hardware interrupt to the internal CPU. The CPU then determines which DPWM outputs are configured to be associated with the voltage rail that contained the fault and disables those DPWM and SRE outputs. This process takes about 14 microseconds. An integrated gate driver such as the UCD7230 can be used to generate the FAULT signal. The UCD7230 monitors the voltage drop across the high side FET and if it exceeds a resistor/voltage programmed threshold, the UCD7230 activates its fault output. The FAULT input can be disabled by reconfiguring the FAULT pin to be a sequencing pin.
2. Inputs CS-1A, CS-2A, CS-3A and CS-4A each drive an internal analog comparator. These comparators can be used to detect the voltage output of a current sense circuit. Each comparator has a separate PMBus configurable threshold. This threshold is set by issuing the FAST_OC_FAULT_LIMIT command. Though the command is specified in amperes, the hardware threshold is programmed with a value between 31mV and 2V in 64 steps. The conversion from amperes to volts is accomplished by issuing the IOUT_CAL_GAIN command. When the current sense voltage exceeds the configured threshold the corresponding DPWM and SRE outputs are driven low on the voltage rail with the fault.
3. Each Current Sense input to the UCD9240 is also monitored by the 12-bit ADC. Each measured value is scaled using the IOUT_CAL_GAIN and IOUT_CAL_OFFSET commands. The currents for each power stage configured as part of a voltage rail are summed and compared to the OC limit set by the IOUT_OC_FAULT_LIMIT command. The action taken when a fault is detected is defined by the IOUT_OC_FAULT_RESPONSE command.

Because the current measurement is averaged with a smoothing filter, the response time to an Overcurrent condition depends on a combination of the time constant (τ) from [Table 4](#), the recent measurement history, and how much the measured value exceeds the overcurrent limit. When the current steps from a current (I_1) that is less than the limit to a higher current (I_2) that is greater than the limit, the output of the smoothing filter is:

$$I_{\text{smoothed}}(t) = I_1 + (I_2 - I_1) \left(1 - e^{-\frac{t}{\tau}} \right) \quad (3)$$

At the point when I_{smoothed} exceeds the limit, the smoothing filter lags time, t_{lag} is:

$$t_{\text{lag}} = \tau \ln \left(\frac{I_2 - I_1}{I_2 - I_{\text{limit}}} \right) \quad (4)$$

The worst case response time to an overcurrent condition is the sum of the sampling interval ([Table 4](#)) and the smoothing filter lag, t_{lag} from the equation above.

Current Foldback Mode

When the measured output current exceeds the value specified by the IOUT_OC_FAULT_LIMIT command, the UCD9240 attempts to continue to operate by reducing the output voltage in order to maintain the output current at the value set by IOUT_OC_FAULT_LIMIT. This continues indefinitely as long as the output voltage remains above the minimum value specified by IOUT_OC_LV_FAULT_LIMIT. If the output voltage is pulled down to less than that value, the device shuts down, if programmed to do so by the IOUT_OC_LV_FAULT_RESPONSE command.

Input Voltage and Current Monitoring

The Vin/lin pin on the UCD9240 monitors the input voltage and current. To measure both input voltage and input current, an external multiplexer is required. If measurement of only the input voltage, and not input current, is desired, then a multiplexer is not needed, see Figure 3. The multiplexer is switched between voltage and current using the TMUX-0 signal. (This signal is the LSB of the temperature mux select signals, so the TMUX-0 signal is connected both to the temperature multiplexer as well as the voltage/current multiplexer). The Vin/lin pin is monitored using the internal 12-bit ADC and so has a dynamic range of 0 to 2.5V. The fault thresholds for the input voltage are set using the VIN_OV_FAULT_LIMIT and VIN_UV_FAULT_LIMIT commands. The scaling for Vin is set using the VIN_SCALE_MONITOR command, and the scaling for lin is set using the IIN_SCALE_MONITOR command.

Temperature Monitoring

Both the internal device temperature and up to eight external temperatures are monitored by the UCD9240. The controller supports multiple PMBus commands related to temperature, including READ_TEMPERATURE_1, which reads the internal temperature, READ_TEMPERATURE_2, which reads the external power stage temperatures, OT_FAULT_LIMIT, which sets the over temperature fault limit, and OT_FAULT_RESPONSE, which defines the action to take when the configured limit is exceeded.

If more than one external temperature is to be measured, the UCD9240 provides analog multiplexer select pins (TMUX0-2) to allow up to 8 external temperatures to be measured. The output of the multiplexer is routed to the Temp pin. The controller cycles through each of the power stage temperature measurement signals. The signal from the external temperature sensor is expected to be a linear voltage proportional to temperature. The PMBus commands TEMPERATURE_CAL_GAIN and TEMPERATURE_CAL_OFFSET are used to scale the measured temperature-dependent voltage to °C.

The inputs to the multiplexer are mapped in the order that the outputs are assigned in the PHASE_INFO PMBus command. For example, if only one power stage is wired to each DPWM, the four temperature signals should be wired to the first four multiplexer input.

The UCD9240 monitors temperature using the 12-bit monitor ADC, sampling each temperature in turn with a 800 ms sample period. These measurements are smoothed by a digital filter, similar to that used to smooth the output current measurements. The filter has a time constant 15.5 times the sample interval, or 12.4 s (15.5 × 800 ms = 12.4 seconds). This filtering reduces the probability of false fault detections.

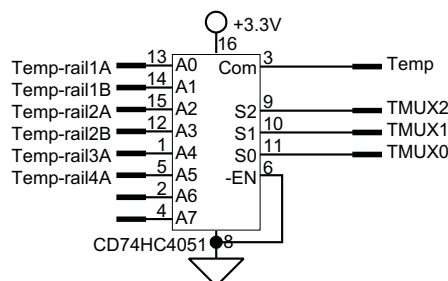

Figure 12. Temperature Mux (4-rail, 6-phase Example)

Below is an example of a system with 2 output voltage rails, where each output is driven by 3 power stages. The first output voltage rail is driven with PWM-1A, PWM -1B, and PWM-3A. The second output voltage rail is driven with PWM-2A, PWM-2B, and PWM-4A. The order in which the temperature multiplexer inputs are assigned are shown in Table 5

Table 5. Temperature Sensor Mapping

TEMPERATURE MUX INPUT	POWER STAGE	RAIL
A0	PWM-1A	Rail-1A
A1	PWM-1B	Rail-1B
A2	PWM-3A	Rail-1C
A3	PWM-2A	Rail-2A

Table 5. Temperature Sensor Mapping (continued)

TEMPERATURE MUX INPUT	POWER STAGE	RAIL
A4	PWM-2B	Rail-2B
A5	PWM-4A	Rail-2C
A6	-	-
A7	-	-

Temperature Balancing

Temperature balancing between phases is performed by adjusting the current such that cooler phases draw a larger share of the current. Temperature balancing occurs slowly (the loop runs at a 10 Hz rate), and only when the phase currents exceeds the PMBus settable TEMP_BALANCE_IMIN. This minimum current threshold prevents the controller from "winding up" and forcing one phase to carry all the current under a low-load condition, when the total current may be insufficient to significantly affect phase temperatures.

Soft Start, Soft Stop Ramp Sequence

The UCD9240 performs soft start and soft stop ramps under closed loop control. Performing a start or stop ramp or tracking is considered a separate operational mode. The other operational modes are normal regulation and light load regulation. Each operational mode can be configured to have an independent loop gain and compensation. Each set of loop gain coefficients is called a "bank" and is configured using the CLA_GAINS PMBus command.

Start ramps are performed by waiting for the configured start delay TON_DELAY and then ramping the internal reference toward the commanded reference voltage at the rate specified by the TON_DELAY time. The DPWM and SRE outputs are enabled when the internal ramp reference equals the preexisting voltage (pre-bias) on the output and the calculated DPWM pulse width exceeds the pulse width specified by DRIVER_MIN_PULSE. This ensures that a constant ramp rate is maintained, and that the ramp is completed at the same time it would be if there was not a pre-bias condition.

The operation of soft-stop ramps depends on how the voltage rail is configured. If PAGE_ISOLATED is set to 1 through the PAGE_ISOLATED PMBus command, the controller assumes that it is the only device driving the voltage rail, and the soft-stop ramp is performed with SRE enabled until the voltage associated with the configured minimum supported pulse width is reached. If PAGE_ISOLATED is set to 0, the controller assumes that multiple power stages may be supplying the voltage rail and SRE is disabled at the beginning of the soft-stop ramp. [Figure 13](#) shows the operation of soft-start ramps and soft-stop ramps.

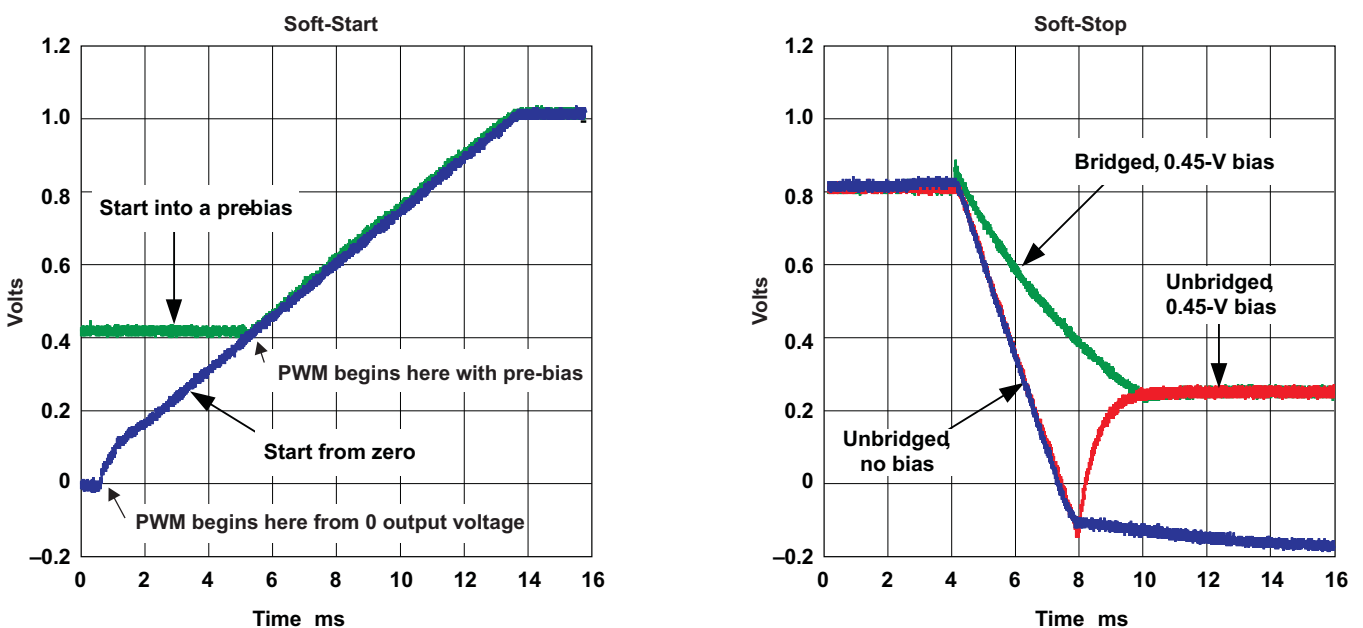
**Figure 13. Start and Stop Ramps**

When a voltage rail is in its idle state, the DPWM and SRE outputs are disabled, and the differential voltage on the EAP/EAN pins are monitored by the controller. During idle the setpoint DAC is adjusted to minimize the error voltage. If there is a pre-bias (that is, a non-zero voltage on the regulated output), then the device can begin the start ramp from that voltage with a minimum of disturbance. This is done by calculating the duty cycle that is required to match the measured voltage on the rail. Nominally this is calculated as V_{in} / V_{out} ; however, to allow for losses and offsets in the system, PREBIAS_GAIN and PREBIAS_OFFSET can be used for fine tuning. If the pre-bias voltage on the output requires a smaller pulse width than the driver can deliver, as defined by the DRIVER_MIN_PULSE PMBus command, then the start ramp is delayed until the internal ramp reference voltage has increased to the point where the required duty cycle exceeds the specified minimum duty.

Once a soft start/stop ramp has begun, the output is controlled by adjusting the setpoint DAC at a fixed rate and allowing the digital compensator control engine to generate a duty cycle based on the error. The setpoint DAC adjustments are made at a rate of 10 kHz and are based on the TON_RISE or TOFF_FALL PMBus configuration parameters.

Although the presence of a pre-bias voltage or a specified minimum DPWM pulse width affects the time when the DPWM and SRE signals become active, the time from when the controller starts processing the turn-on command to the time when it reaches regulation is TON_DELAY plus TON_RISE, regardless of the pre-bias or minimum duty cycle.

During a normal ramp (i.e. no tracking, no current limiting events and no EADC saturation), the setpoint slews at a pre-calculated rate based on the commanded output voltage and TON_RISE. Under closed loop control, the compensator follows this ramp up to the regulation point.

Because the EADC in the controller has a limited range, it may saturate due to a large transient during a start/stop ramp. If this occurs, the controller overrides the calculated setpoint ramp value, and adjusts the reference DAC in the direction to minimize the error. It continues to step the reference DAC in this direction until the EADC comes out of saturation. Once it is out of saturation, the start ramp continues, but from this new setpoint voltage; and therefore, has an impact on the ramp time.

Input UV Lockout

The normal operation supply lock-out voltage thresholds are configured with the VIN_ON and VIN_OFF commands. When input supply voltage drops below the value set by VIN_OFF, the device starts a normal soft stop ramp. When the input supply voltage drops below the voltage set by VIN_UV_FAULT_LIMIT, the device performs per the configuration using the VIN_UV_FAULT_RESPONSE command. For example, when the bias supply for the controller is derived from another source, the response code can be set to "Continue" or "Continue with delay," and the controller attempts to finish the soft stop ramp. If the bias voltages for the controller and gate driver are uncertain below some voltage, the user can set the UV fault limit to that voltage and specify the response code to be "shut down immediately" disabling all DPWM and SRE outputs. If VIN_OFF sets the voltage at which the output voltage soft-stop ramp is initiated, and VIN_UV_FAULT_LIMIT sets the voltage where power conversion is stopped.

Voltage Tracking

Each voltage rail can be configured to operate in a tracking mode. When a voltage rail is configured to track another voltage rail, it adjusts the setpoint to follow the master, which can be either another internal rail or the external Vtrack pin. As in standard non-tracking mode, a target Vout is still specified for the voltage rail. If the tracking input exceeds this target, the tracking voltage rail stops following the master signal, switch to regulation gains, and regulate at the target voltage. When the tracking input drops back below the target (with 20 mV of hysteresis), tracking gains is re-loaded, and the voltage rail follows the tracking reference. Note that the target can be set above the range of the tracking input, forcing the voltage rail to always remain in tracking mode.

During tracking, the setpoint DAC is permitted to change only as fast as is possible without inducing the EADC to saturate. This limit may be reached if the master ramps at an extremely fast rate, or if the master is at a significantly different voltage when the rail is turned on. As in normal regulation, a current limit (current foldback) or the detection of the EADC saturating forces the rail to temporarily deviate from the tracking reference.

The PMBus command TRACKING_SOURCE is available to enable tracking mode and select the master to track. The tracking mode is set individually for each rail, allowing each rail to have a different master, multiple rails to share a master, or some rails to track while others remain independent. Additionally, TRACKING_SCALE_MONITOR permits tracking at voltage with a fixed ratio to a master voltage. For example, a ratio of 0.5 causes the rail to regulate at one half of the master's voltage.

Sequencing

There are three methods to sequence voltage rails controlled by the UCD9240 that allow for a variety of system sequencing configurations. Each of these options is configurable in the GUI. These methods include:

1. Use the PMBus to set the soft start/stop parameters for each rail. Multiple start/stop sequences may be triggered simultaneously. Each voltage rail performs its sequencing in an open-loop manner. If any rail fails to complete its sequence, all other rails are unaffected.
2. Daisy-chain the Power Good output signal from one controller to the PMBus-CTRL input on another.
3. Use the GPIO_SEQ_CONFIG command to assign dependencies between rails, or to configure unused pins as sequencing control inputs or sequencing status outputs.

Method 1: Each rail has programmable delay times, TON_DELAY and TOFF_DELAY, before beginning a soft start ramp or a soft stop ramp, and programmable ramp times, TON_RISE and TOFF_FALL determine how long the ramp takes. These PMBus commands are defined in the UCD92xx PMBUS Command Reference. The parameters can also be configured using the Fusion Digital Power™ Designer GUI (see http://focus.ti.com/docs/toolsw/folders/print/fusion_digital_power_designer.html). The configurable times can be used to program a time based sequence for each voltage rail. Using this method each rail ramps independently and completes the ramp regardless of the success of the other rails.

The start/stop sequence is initiated for a single rail by the PMBus-CTRL pin or via the PMBus using the OPERATION or ON_OFF_CONTROL commands.

The start/stop sequence may be initiated simultaneously for multiple rails within the same controller by configuring each rail to respond to the PMBus-CTRL pin. Alternatively, after setting the PMBus PAGE variable to 255, subsequent OPERATION or ON_OFF_CONTROL commands applies to all rails at the same time.

To simultaneously initiate start/stop sequences in multiple controllers, a common PMBus-CTRL signal can be fed into each controller. Alternatively, the PMBus Group Command Protocol may be used to send separate commands to multiple controllers. All the commands are sent in one continuous transmission and wait for the final STOP signal in order to start executing their commands simultaneously.

Method 2: The Power Good pin can be used to coordinate multiple controllers by running the Power Good pin output from one controller to the PMBus-CTRL input pin of another. This imposes a master/slave relationship between multiple devices. During startup, the slave controllers initiates their start sequences after the master completes its start sequence and reaches its regulation voltage. During shut-down, as soon as the master starts its shut-down sequence, the shut-down signals to its slaves.

Unlike Method 1, a shut-down on one or more rails on the master can initiate shut-downs of the slave devices. The master shut-downs can initiate intentionally or by a fault condition.

The PMBus specification implies that the Power Good signal is active when ALL the rails in a controller are above their power-good “on” threshold setting. The UCD9240 allows the Power Good pin to be reprogrammed using the GPIO_SEQ_CONFIG command so that the pin responds to a desired subset of rails.

This method works to coordinate multiple controllers, but it does not enforce interdependency between rails within a single controller.

Method 3: Using the GPIO_SEQ_CONFIG command, several sequencing options can be configured using undedicated pins for input/output. As many as four pins can be configured as inputs, and as many as eight as outputs. The outputs can be open-drain or actively driven with selectable polarity.

Each rail can be configured to respond to a combination of the power-good status of other internal rails and/or the state of sequencing input pins. The output pins can be configured to reflect the power-good status of a combination of rails, or to one of several status indicators including power-good, an Overcurrent warning, or the “open-drain outputs valid” signal.

When using the output signals for sequencing, they may be routed to sequencing control inputs or to the PMBus-CTRL inputs on other controllers.

Once each rail’s input dependencies are configured, the rail responds to those input pins or internal rails. Like method 2, shut-downs on one rail or controller can initiate shut-downs of other rails or controllers. Unlike method 2, GPIO_SEQ_CONFIG offers much more flexibility in assigning relationships between multiple rails within a single controller or between multiple controllers. It is possible for each controller to be both a master and a slave to another controller.

GPIO_SEQ_CONFIG allows the configuration of fault relationships such that a fault on one rail can result in the shut down of any selection of rails in addition to the rail at fault. These fault interactions are not constrained to a single master/slave relationship; for example, a system can be configured such that a fault on any rail shuts down all rails. If the fault response of the failing rail is to shut down immediately, all dependent rails follow suit and shuts down immediately regardless of their programmed response code.

Each rail can be optionally configured to monitor a sequencing input pin for a specified period of time after it turns on and reaches its power good threshold. If the programmable timeout is reached before the input pin state matches its defined logic level, the rail is shut down, and a status error posted. This feature could be used, for example, to ensure that an LDO on the board did turn on when the main system voltage came up. Each rail is enabled independently of the other rails and has a unique timeout value; a single input pin is used as the timeout source.

The setup of the GPIO_SEQ_CONFIG command is aided by the use of the Fusion Digital Power™ Designer, which graphically displays relationships between rails and provides intuitive controls to allocate and configure available resources.

The following pins are available for use as GPIO or sequencing control, provided they are not being used for their primary purpose:

PIN NAME	80-PIN	64-PIN
DPWM-1A	IN/OUT	IN/OUT
DPWM-1B	IN/OUT	IN/OUT
DPWM-2A	IN/OUT	IN/OUT
DPWM-2B	IN/OUT	IN/OUT
DPWM-3A	IN/OUT	IN/OUT
DPWM-3B	IN/OUT	–
DPWM-4A	IN/OUT	IN/OUT
DPWM-4B	IN/OUT	–
FAULT-1A	IN/OUT	IN/OUT
FAULT-1B	IN/OUT	IN/OUT
FAULT-2A	IN/OUT	IN/OUT
FAULT-2B	IN/OUT	IN/OUT
FAULT-3A	IN/OUT	IN/OUT
FAULT-3B	IN/OUT	–
FAULT-4A	IN/OUT	IN/OUT
FAULT-4B	IN/OUT	–
SRE-1A	IN/OUT	IN/OUT
SRE-1B	IN/OUT	IN/OUT
SRE-2A	IN/OUT	IN/OUT
SRE-2B	IN/OUT	IN/OUT
SRE-3A	IN/OUT	IN/OUT
SRE-3B	IN/OUT	–
SRE-4A	IN/OUT	IN/OUT
SRE-4B	IN/OUT	–
POWER_GOOD	IN/OUT	IN/OUT
FAN_TACH	IN/OUT	IN/OUT
FAN_PWM	IN ⁽¹⁾	IN ⁽¹⁾
DIAG_LED	IN ⁽¹⁾	–

(1) The FAN_PWM and Diag_LED pins are outputs when configured for their primary purpose. When configured for sequencing, they may be used only as inputs.

Fan Control

The UCD9240 can control one fan as defined in the PMBus standard. When enabled, the FAN-PWM control output provides a 156 kHz digital signal, with a duty cycle that is set based on the FAN_COMMAND_1 PMBus command. The duty cycle can be set from 0% to 100% with 1% resolution.

The FAN-TACH input counts the number of transitions in the tachometer output from the fan in each 1 second interval. The fan speed may be read by issuing the READ_FAN_SPEED_1 command. The speed is returned in RPMs.

Different fans may output from one to four tachometer pulses per revolution. The FAN_CONFIG_1_2 command is used to set the number of tachometer pulses per revolution. The same command is used to indicate whether a fan is attached.

The UCD9240 can report fan speed faults when the fan speed is too slow for 5 consecutive seconds. The fan speed fault limit is set by the FAN_SPEED_FAULT_LIMIT command. The status is checked by issuing the STATUS_FAN_1_2 command. See the UCD92xx PMBUS Command Reference for a complete description of each command.

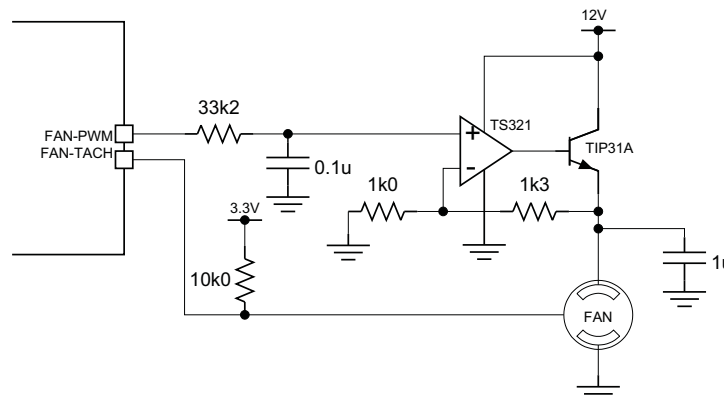

Figure 14. Example Fan Control Circuit

Non-volatile Memory Error Correction Coding

The UCD9240 uses Error Correcting Code (ECC) to improve data integrity and provide high reliability storage of Data Flash contents. ECC uses dedicated hardware to generate extra check bits for the user data as it is written into the Flash memory. This adds an additional six bits to each 32-bit memory word stored into the Flash array. These extra check bits, along with the hardware ECC algorithm, allow for any single bit error to be detected and corrected when the Data Flash is read.

APPLICATION INFORMATION

Calculation of Open Loop Gain Using the UCD9240

When designing a power supply it is necessary to determine the stability of the closed loop system. The usual way to do this is to determine the open loop gain versus frequency and from the open loop gain determine the gain margin and phase margin. Figure 15 shows a block diagram of a complete control loop using the UCD9240. Each component of the loop gain that is a function of frequency is labeled "Gx". Constant gain components are labeled "Kx".

CONSTANT GAIN COMPONENTS	DESCRIPTION
G_{plant}	Transfer function for the power stage circuit consisting of the FET switches, LC output filter and load.
G_{div}	Transfer function for the VOUT sense divider and its capacitive filter network.
K_{AFE}	Analog front-end amplifier gain.
K_{EADC}	Gain of the 6-bit EADC in units of LSBs/V

CONSTANT GAIN COMPONENTS	DESCRIPTION
G_{delay}	Phase shift due to the delays in the control loop.
$K_{\text{nonlinear}}$	Nonlinear function gain. Gain for the limit interval that contains zero error.
G_{CLA2}	Transfer function of the second order filter section of the compensator.
G_{CLA1}	Transfer function of the first order filter section of the compensator.
K_{PWM}	Accounts for the bit resolution of the input to the DPWM

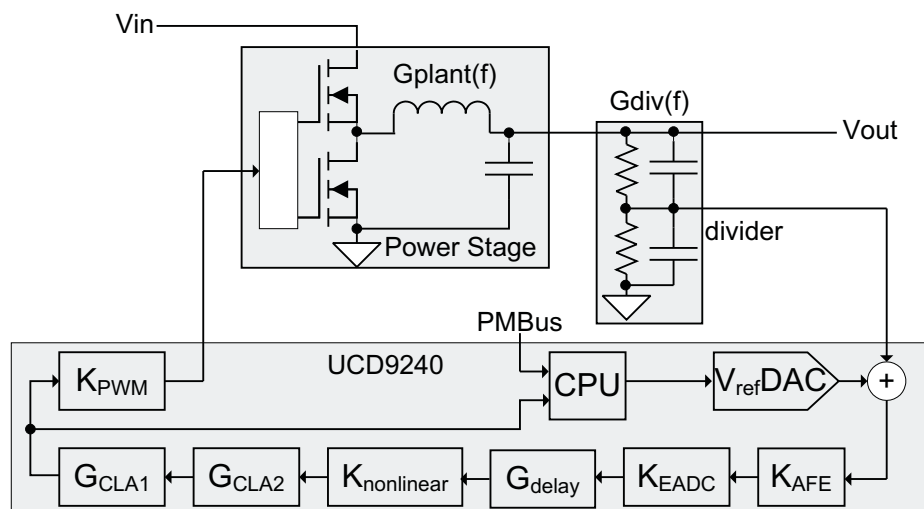

Figure 15. Loop Gain Contributions

Several of the gain blocks are programmable. They are configured by issuing a CLA_GAINS command over the PMBus. The syntax for this command is shown in the UCD92xx PMBUS Command Reference. These gains can also be configured using the Fusion Digital Power™ Designer PC program.

Automatic System Identification (Auto-ID™)

By using digital circuits to create the control function for a switch-mode power supply, additional features can be implemented. One of those features is the measurement of the open loop gain and stability margin of the power supply without the use of external test equipment. This capability is called automatic system identification or Auto-ID™. To identify the frequency response, the UCD9240 internally synthesizes a sine wave signal and injects it into the loop at the set point DAC. This signal excites the system, and the closed-loop response to that excitation can be measured at another point in the loop. The UCD9240 measures the response to the excitation at the output of the digital compensator. From the closed-loop response, the open-loop transfer function is calculated. The open-loop transfer function may be calculated from the closed-loop response.

Note that since the compensator and DPWM are digital, their transfer functions are known exactly and can be divided out of the measured open-loop gain. In this way the UCD9240 can accurately measure the power stage/load plant transfer function in situ (in place), on the factory floor or in an end equipment application and send the measurement data back to a host through the PMBus interface without the need for external test equipment. Details of the Auto-ID™ PMBus measurement commands can be found in the UCD92xx PMBus Command Reference.

EAp/EAn Voltage Sense Filtering

Conditioning should be provided on the EAp and EAn signals. Figure 16 shows a divider network between the output voltage and the voltage sense input to the controller. The resistor divider is used to bring the output voltage within the dynamic range of the controller. When no attenuation is needed, R2 can be left open and the signal conditioned by the low-pass filter formed by R1 and C2.

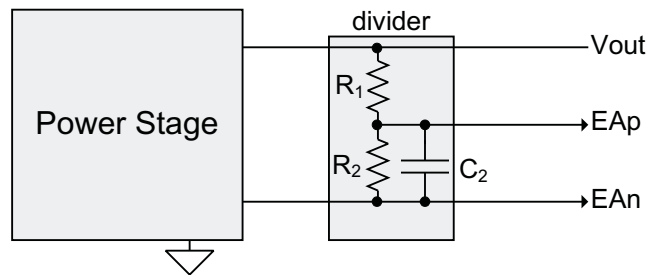

Figure 16. EAp/EAn Input Network

As with any power supply system, maximize the accuracy of the output voltage by sensing the voltage directly across an output capacitor, and route the positive and negative differential sense signals as a balanced pair of traces or as a twisted pair cable back to the controller. Put the divider network close to the controller. This ensures that there is a low impedance driving the differential voltage sense signal from the voltage rail output back to the controller. The resistance of the divider network is a trade-off between power loss and minimizing interference susceptibility. A parallel resistance of 1k to 4kΩ is a good compromise.

$$R_1 = \frac{R_P}{K} \quad R_2 = \frac{R_P}{1-K} \quad \text{where } K = \frac{V_{EA}}{V_{OUT}} \quad \text{and } R_P = \frac{R_1 R_2}{R_1 + R_2}$$

It is recommended that a capacitor be placed across the lower resistor of the divider network. This acts as an additional pole in the compensation and as an anti-alias filter for the EADC. To be effective as an anti-alias filter, the corner frequency should be 35% to 40% of the switching frequency. Then the capacitor is calculated as:

$$C_2 = \frac{1}{2\pi \times 0.35 \times F_{SW} \times R_P}$$

Current Sense Input Filtering

Each power stage current is monitored by the device at the CS pins. There are 4 "A" channel pins and 2 or 4 "B" channel pins (64 or 80 pin package). The B channels monitor the current with a 12-bit ADC and samples each current sense voltage in turn. The A channels monitor the current with the same 12-bit ADC and also monitor the current with a digitally programmable analog comparator.

Because the current sense signal is digitally sampled, it should be conditioned with an RC network acting as an anti-alias filter. Since the sample rate for the CS inputs is $1/T_{out}$, a good cutoff frequency for the RC network is from 2 kHz to 3 kHz.

Output Voltage Margining

The UCD9240 supports Voltage Margining using the PMBus VOUT_MARGIN_HIGH and VOUT_MARGIN_LOW commands in conjunction with the OPERATION command. The margin voltages can be configured at device configuration and saved into Data Flash. The output can be commanded to switch between Margin High, Nominal, and Margin Low using bits [3:2] of the OPERATION command.

Calibration

To optimize the operation of the UCD9240, PMBus commands are supplied to enable fine calibration of output voltage, output current, and temperature measurements. The supported commands and related calibration formulas may be found in the UCD92xx PMBUS Command Reference.

Data Logging

The UCD9240 maintains a data log in non-volatile memory. This log tracks the peak internal and external temperature measurements, peak current measurements, and fault history. The PMBus commands and data format for data logging can be found in the UCD92xx PMBUS Command Reference ([SLUU337](#))

continues to take reasonable steps to provide representative and accurate information but may not have conducted destructive testing or chemical analysis o
TI and TI suppliers consider certain information to be proprietary, and thus CAS numbers and other limited information may not be available for release.

In no event shall TI's liability arising out of such information exceed the total purchase price of the TI part(s) at issue in this document sold by TI to Customer o

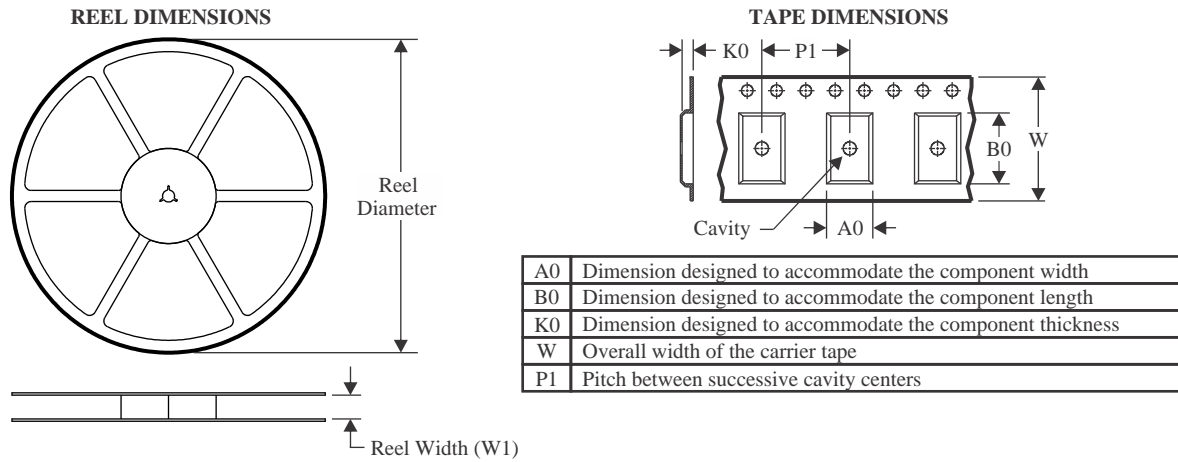
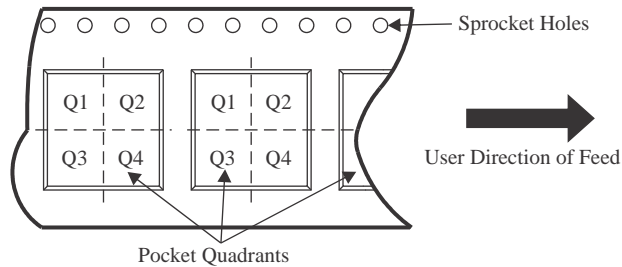
TAPE AND REEL INFORMATION

QUADRANT ASSIGNMENTS FOR PIN 1 ORIENTATION IN TAPE

*All dimensions are nominal

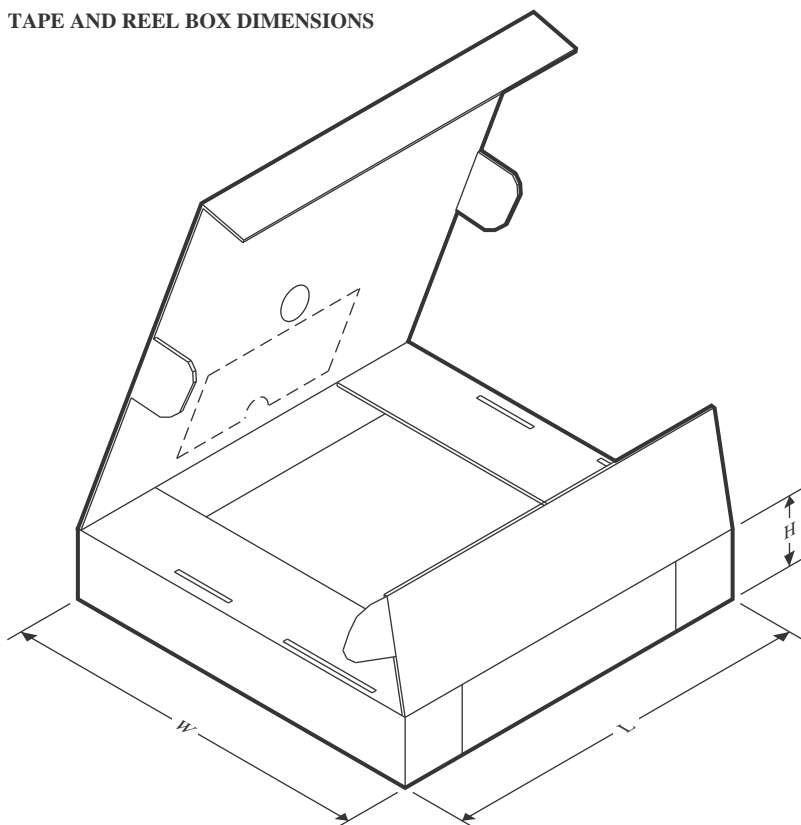
Device	Package Type	Package Drawing	Pins	SPQ	Reel Diameter (mm)	Reel Width W1 (mm)	A0 (mm)	B0 (mm)	K0 (mm)	P1 (mm)	W (mm)	Pin1 Quadrant
UCD9240PFCR	TQFP	PFC	80	1000	330.0	24.4	15.0	15.0	1.5	20.0	24.0	Q2
UCD9240RGCR	VQFN	RGC	64	2000	330.0	16.4	9.3	9.3	1.5	12.0	16.0	Q2
UCD9240RGCT	VQFN	RGC	64	250	180.0	16.4	9.3	9.3	1.5	12.0	16.0	Q2

TAPE AND REEL BOX DIMENSIONS

*All dimensions are nominal

Device	Package Type	Package Drawing	Pins	SPQ	Length (mm)	Width (mm)	Height (mm)
UCD9240PFCR	TQFP	PFC	80	1000	350.0	350.0	43.0
UCD9240RGCR	VQFN	RGC	64	2000	367.0	367.0	38.0
UCD9240RGCT	VQFN	RGC	64	250	210.0	185.0	35.0

TRAY

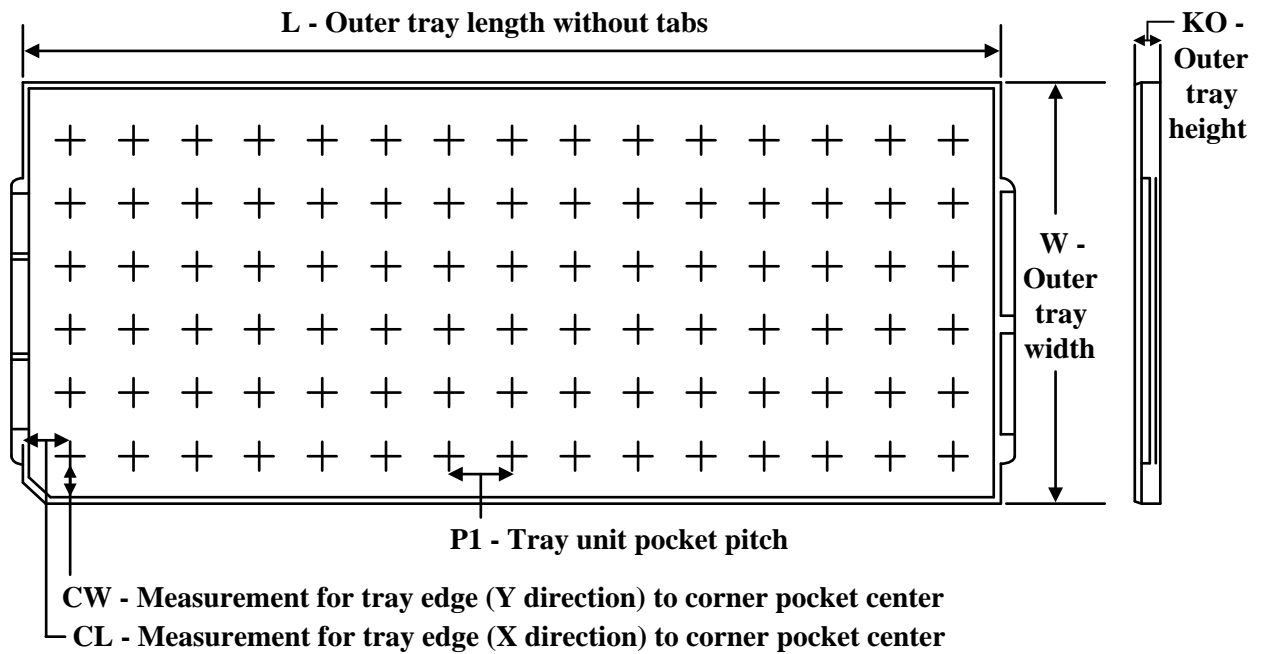

Chamfer on Tray corner indicates Pin 1 orientation of packed units.

*All dimensions are nominal

Device	Package Name	Package Type	Pins	SPQ	Unit array matrix	Max temperature (°C)	L (mm)	W (mm)	K0 (µm)	P1 (mm)	CL (mm)	CW (mm)
UCD9240PFC	PFC	TQFP	80	96	6 x 16	150	315	135.9	7620	18.7	17.25	18.3

GENERIC PACKAGE VIEW

RGC 64

VQFN - 1 mm max height

9 x 9, 0.5 mm pitch

PLASTIC QUAD FLATPACK - NO LEAD

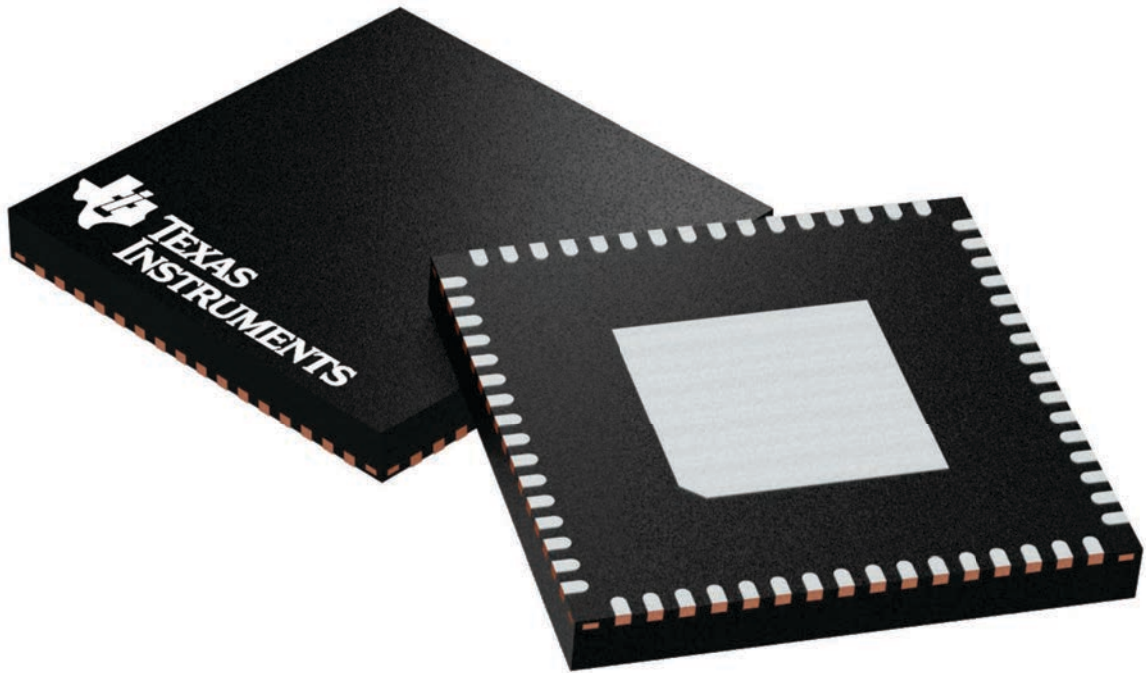

Images above are just a representation of the package family, actual package may vary.
Refer to the product data sheet for package details.

4224597/A

EXAMPLE BOARD LAYOUT

RGC0064B

VQFN - 1 mm max height

PLASTIC QUAD FLATPACK - NO LEAD

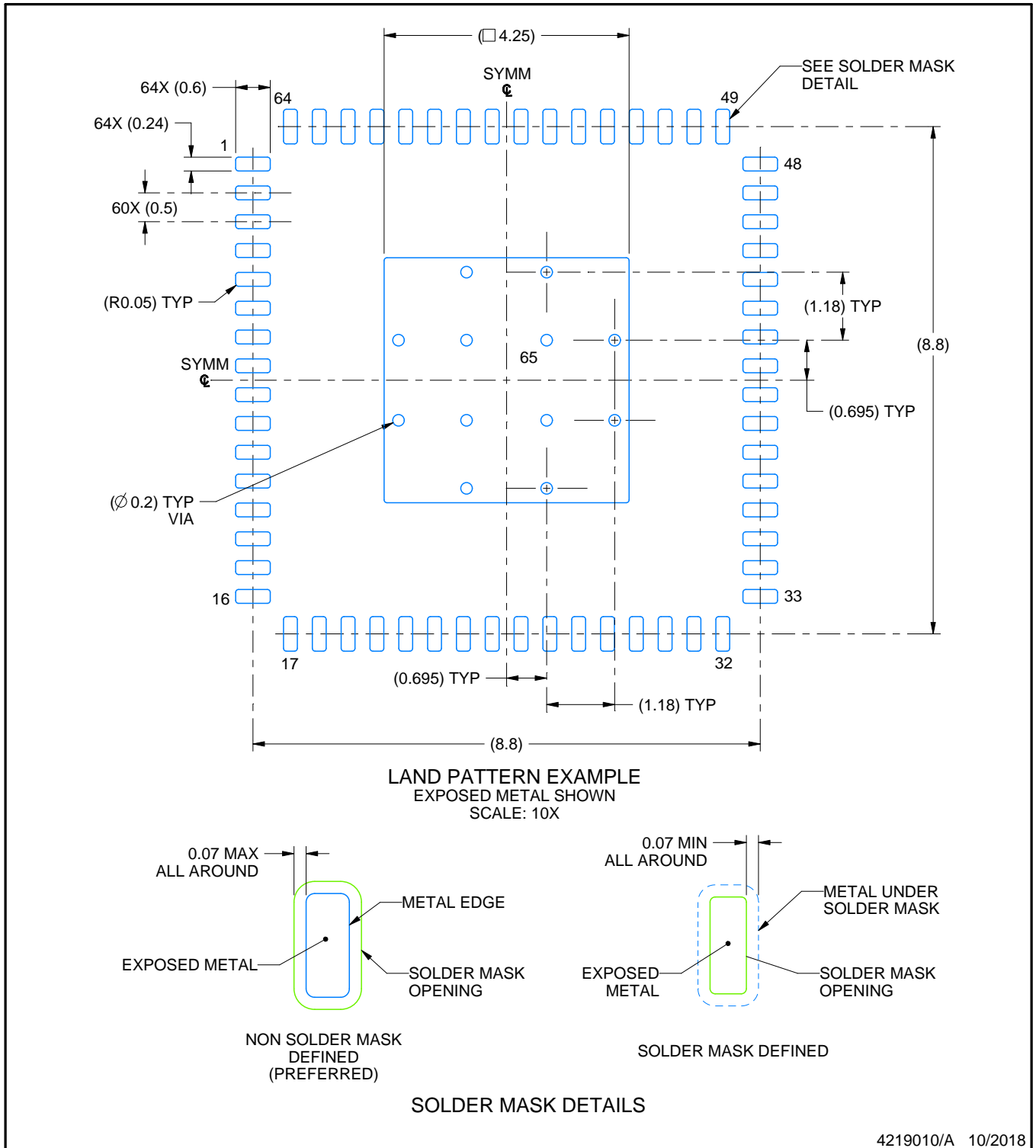

NOTES: (continued)

4. This package is designed to be soldered to a thermal pad on the board. For more information, see Texas Instruments literature number SLUA271 (www.ti.com/lit/slua271).
5. Vias are optional depending on application, refer to device data sheet. If any vias are implemented, refer to their locations shown on this view. It is recommended that vias under paste be filled, plugged or tented.

EXAMPLE STENCIL DESIGN

RGC0064B

VQFN - 1 mm max height

PLASTIC QUAD FLATPACK - NO LEAD

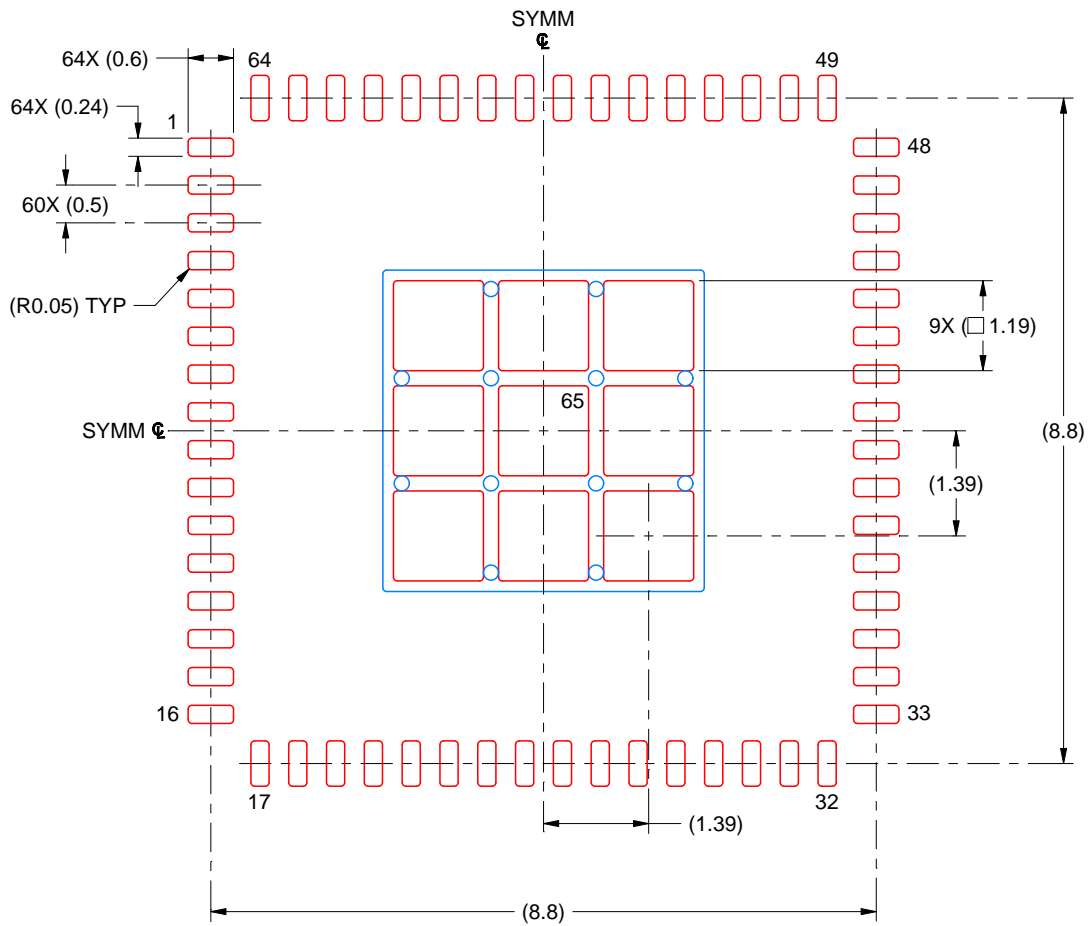

SOLDER PASTE EXAMPLE
BASED ON 0.125 MM THICK STENCIL
SCALE: 10X
EXPOSED PAD 65
71% PRINTED SOLDER COVERAGE BY AREA UNDER PACKAGE

4219010/A 10/2018

NOTES: (continued)

6. Laser cutting apertures with trapezoidal walls and rounded corners may offer better paste release. IPC-7525 may have alternate design recommendations.

PFC0080A

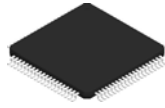

PACKAGE OUTLINE

TQFP - 1.2 mm max height

PLASTIC QUAD FLATPACK

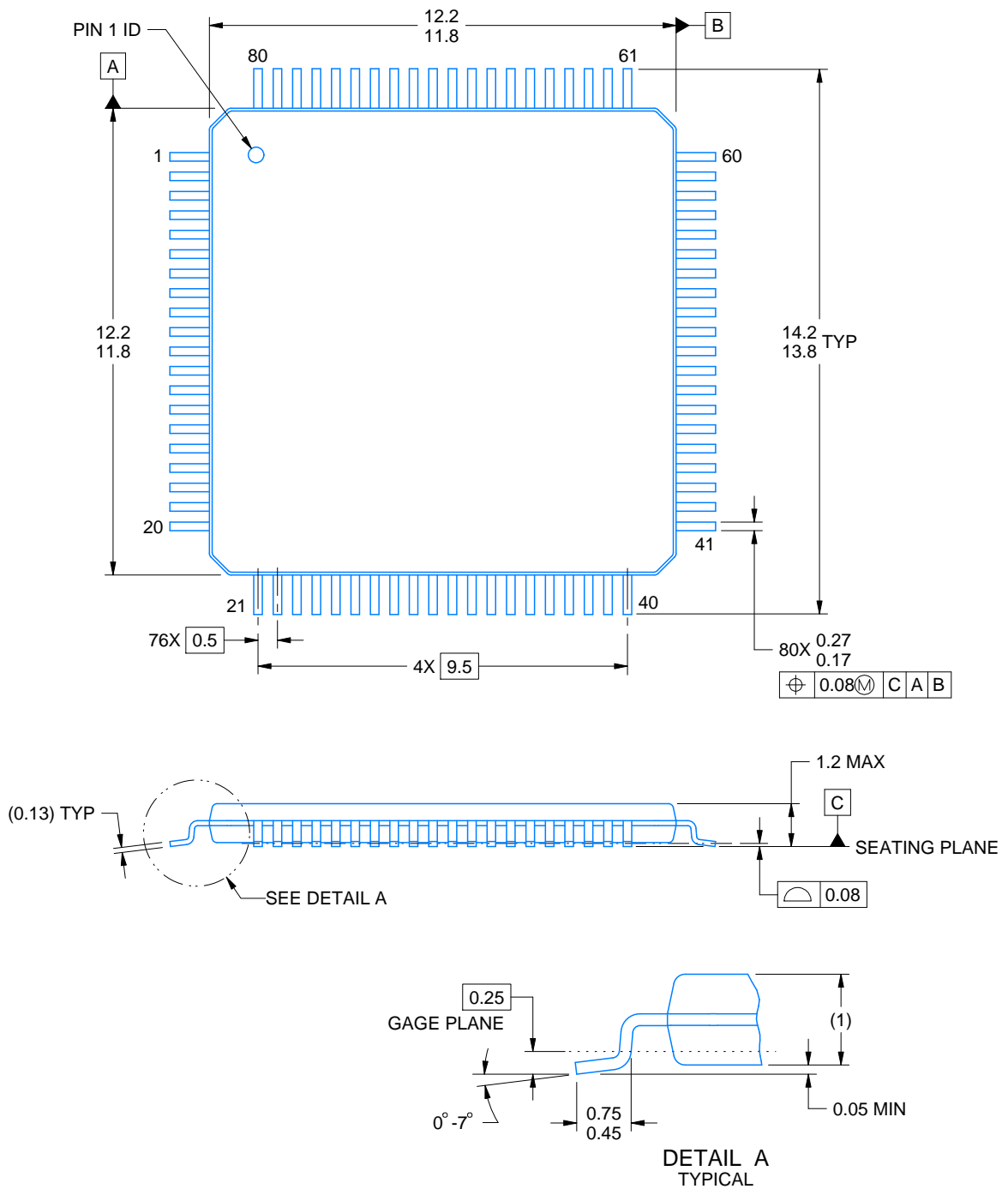

4215165/B 06/2017

NOTES:

1. All linear dimensions are in millimeters. Any dimensions in parenthesis are for reference only. Dimensioning and tolerancing per ASME Y14.5M.
2. This drawing is subject to change without notice.
3. Reference JEDEC registration MS-026.

EXAMPLE BOARD LAYOUT

PFC0080A

TQFP - 1.2 mm max height

PLASTIC QUAD FLATPACK

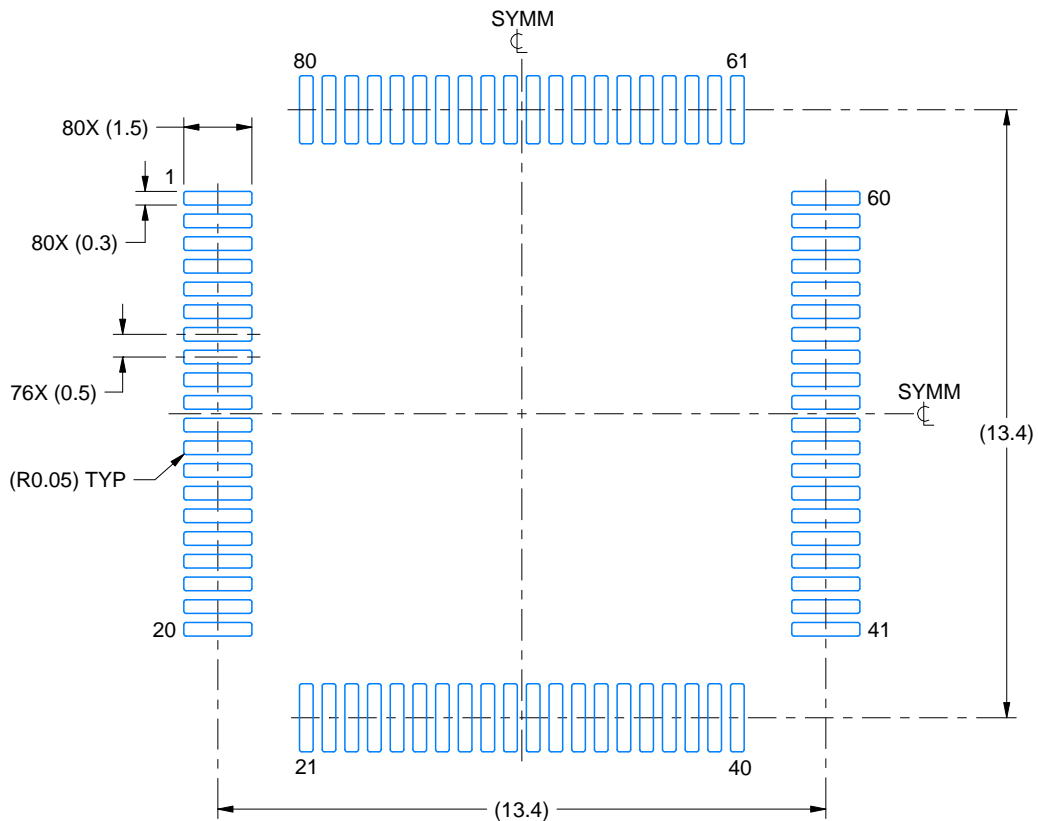

LAND PATTERN EXAMPLE
EXPOSED METAL SHOWN
SCALE:6X

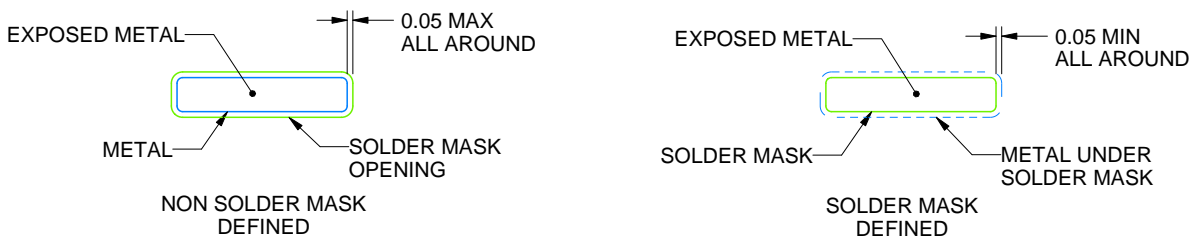

SOLDER MASK DETAILS

4215165/B 06/2017

NOTES: (continued)

4. Publication IPC-7351 may have alternate designs.
5. Solder mask tolerances between and around signal pads can vary based on board fabrication site.
6. For more information, see Texas Instruments literature number SLMA004 (www.ti.com/lit/slma004).

EXAMPLE STENCIL DESIGN

PFC0080A

TQFP - 1.2 mm max height

PLASTIC QUAD FLATPACK

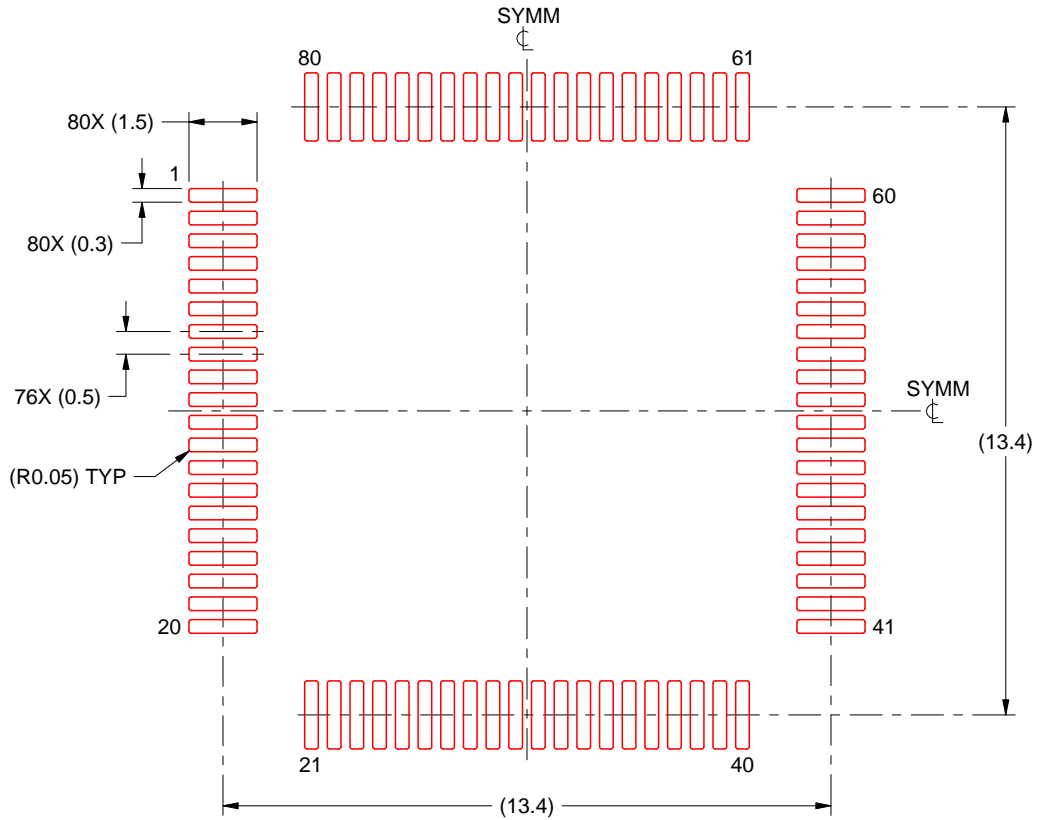

SOLDER PASTE EXAMPLE
BASED ON 0.1 mm THICK STENCIL
SCALE:6X

4215165/B 06/2017

NOTES: (continued)

7. Laser cutting apertures with trapezoidal walls and rounded corners may offer better paste release. IPC-7525 may have alternate design recommendations.
8. Board assembly site may have different recommendations for stencil design.

IMPORTANT NOTICE AND DISCLAIMER

TI PROVIDES TECHNICAL AND RELIABILITY DATA (INCLUDING DATA SHEETS), DESIGN RESOURCES (INCLUDING REFERENCE DESIGNS), APPLICATION OR OTHER DESIGN ADVICE, WEB TOOLS, SAFETY INFORMATION, AND OTHER RESOURCES "AS IS" AND WITH ALL FAULTS, AND DISCLAIMS ALL WARRANTIES, EXPRESS AND IMPLIED, INCLUDING WITHOUT LIMITATION ANY IMPLIED WARRANTIES OF MERCHANTABILITY, FITNESS FOR A PARTICULAR PURPOSE OR NON-INFRINGEMENT OF THIRD PARTY INTELLECTUAL PROPERTY RIGHTS.

These resources are intended for skilled developers designing with TI products. You are solely responsible for (1) selecting the appropriate TI products for your application, (2) designing, validating and testing your application, and (3) ensuring your application meets applicable standards, and any other safety, security, regulatory or other requirements.

These resources are subject to change without notice. TI grants you permission to use these resources only for development of an application that uses the TI products described in the resource. Other reproduction and display of these resources is prohibited. No license is granted to any other TI intellectual property right or to any third party intellectual property right. TI disclaims responsibility for, and you will fully indemnify TI and its representatives against, any claims, damages, costs, losses, and liabilities arising out of your use of these resources.

TI's products are provided subject to [TI's Terms of Sale](#) or other applicable terms available either on ti.com or provided in conjunction with such TI products. TI's provision of these resources does not expand or otherwise alter TI's applicable warranties or warranty disclaimers for TI products.

TI objects to and rejects any additional or different terms you may have proposed.

Mailing Address: Texas Instruments, Post Office Box 655303, Dallas, Texas 75265
Copyright © 2023, Texas Instruments Incorporated