

Pb-free & RoHs Product

Features

- 960~1800MHz Frequency Range
- 30dB Power Gain (Typ.)
- 38dBm Saturation Output Power
- 10dB Input Return Loss
- 3.3~5.5V Supply Voltage
- 12mA Quiescent Current
- Integrated Output Power Detector
- Integrated ESD Protection Unit
- Advanced InGaP/GaAs HBT Technology

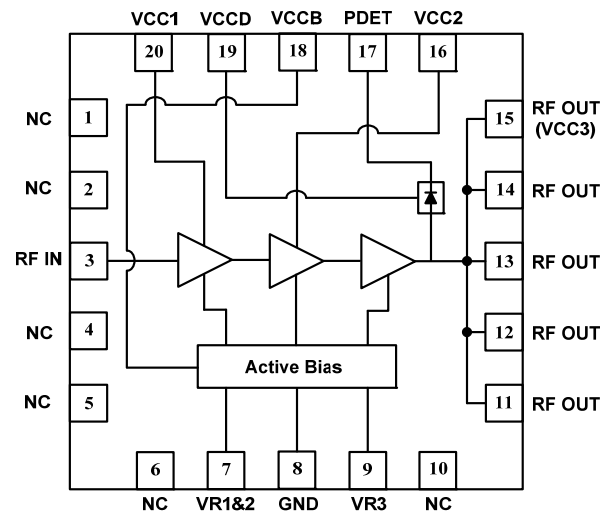

Functional Block Diagram

Applications

- BDS Satellite Communication and Navigation
- Unmanned Aerial Vehicle System
- 1.4GHz Drone Image Transmission
- Air traffic control systems (ATC)

Product Description

The YP163038 is a high-power, high-efficiency Power Amplifier optimized for the applications in bands from 960MHz to 1800MHz (it needs different matching circuit for different frequency range), such as BDS Satellite Communication and 1.4GHz Drone Image Transmission. The Power Amplifier provides a typical power gain of 30dB and saturation power of 38dBm with CW input, typical quiescent bias condition is 5.0V at 12mA. The device is manufactured on an advanced InGaP/GaAs Heterojunction Bipolar Transistor (HBT) process. The YP163038 is assembled in a 20-pin, 5mm×5mm, QFN package, it is internally integrated with ESD protection unit.

Ordering Information

- YP163038 1.6GHz Power Amplifier Chip
- YP163038-EVB YP163038 Evaluation Board of 960-1215MHz, 1.4GHz, 1.6GHz

Pin Description

Pin No.	Symbol	Description
3	RF IN	RF input
7, 9	VR1&2, VR3	Bias current control voltage
11, 12, 13, 14, 15	RF OUT (VCC3)	RF output and Supply voltage for stage 3
16	VCC2	Supply voltage for stage 2
17	PDET	Power detect
18	VCCB	Supply voltage for bias
19	VCCD	Supply voltage for power detector
20	VCC1	Supply voltage for stage 1e
1, 2, 4, 5, 6, 10	NC/GND	No connection or ground
8, PKG Base	GND	Ground connection

Absolute Maximum Ratings

Parameter	Symbol	Rating	Unit
Input RF Power	RF IN	+10	dBm
Supply Voltage	VCC1,VCC2,VCC3, VCCB,VCCD	-0.5 to +6.0	V
Reference Voltage	VR1&2, VR3	-0.5 to +3.0	V
Operating Ambient Temperature	T _{OP}	-40 to +105	°C
Storage Temperature	T _{ST}	-40 to +150	°C



Caution! ESD Sensitive Device.

ESD Rating: Class1C
 Value: Passes ≥1000V min.
 Test: Human Body Model (HBM)
 Standard: JEDEC Standard JESD22-A114

ESD Rating: Class IV
 Value: Passes ≥1000V min.
 Test: Charged Device Model (CDM)
 Standard: JEDEC Standard JESD22-C101

MSL Rating: Level 3 at +260 °C convection reflow
 Standard: JEDEC Standard J-STD-020

Electrical Specifications

Parameter	Specification			Unit	Condition
	Min.	Typ.	Max.		
Compliance and Nominal Conditions					VCC1=VCC2=VCC3=VCCB=5.0V, ICQ=12mA, T _{OP} =+25°C
Frequency range		1615		MHz	
Saturation output power		38.3		dBm	Pulse Mode: Period=1s, Width=300ms
Power gain		30.0		dB	@P _{out} =38.3dBm
Input return loss		10.0		dB	
Reference Voltage		2.4		V	
Quiescent current, ICQ		12		mA	VR1&2=VR3=2.4V
Operating current, ICC		2920		mA	@P _{out} =38.3dBm

Typical Performance

(Test Condition: Freq=1615MHz, VCC1=VCC2=VCC3=VCCB=5V, VR1&2=VR3=2.4V, T_{OP}=+25°C)

PGain vs. Output Power

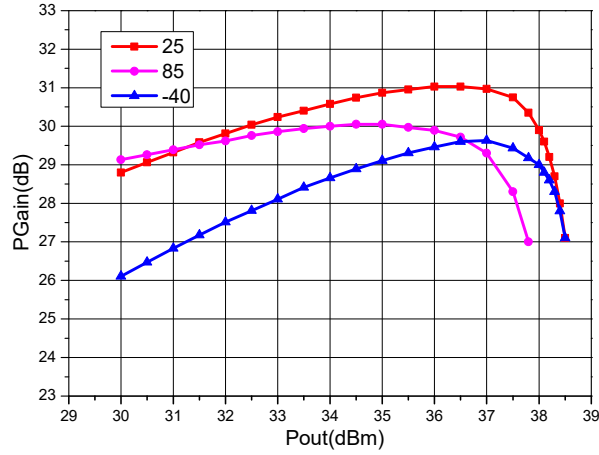

ICC vs. Output Power

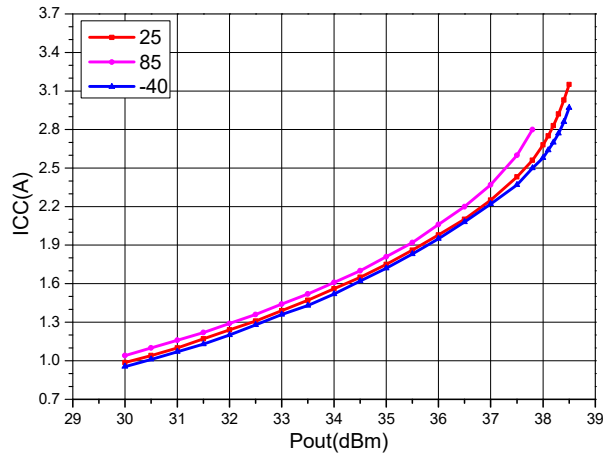

Efficiency vs. Output Power

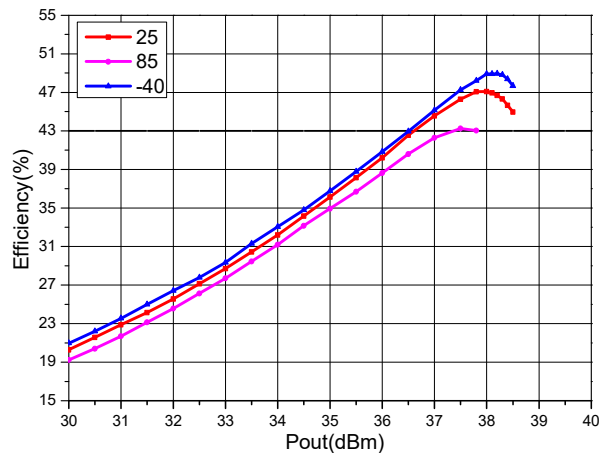

Evaluation Board Schematic

(Test Condition: Freq=1615MHz, VCC1=VCC2=VCC3=VCCB=5V, VR1&2=VR3=2.4V, T_{OP}=+25°C)

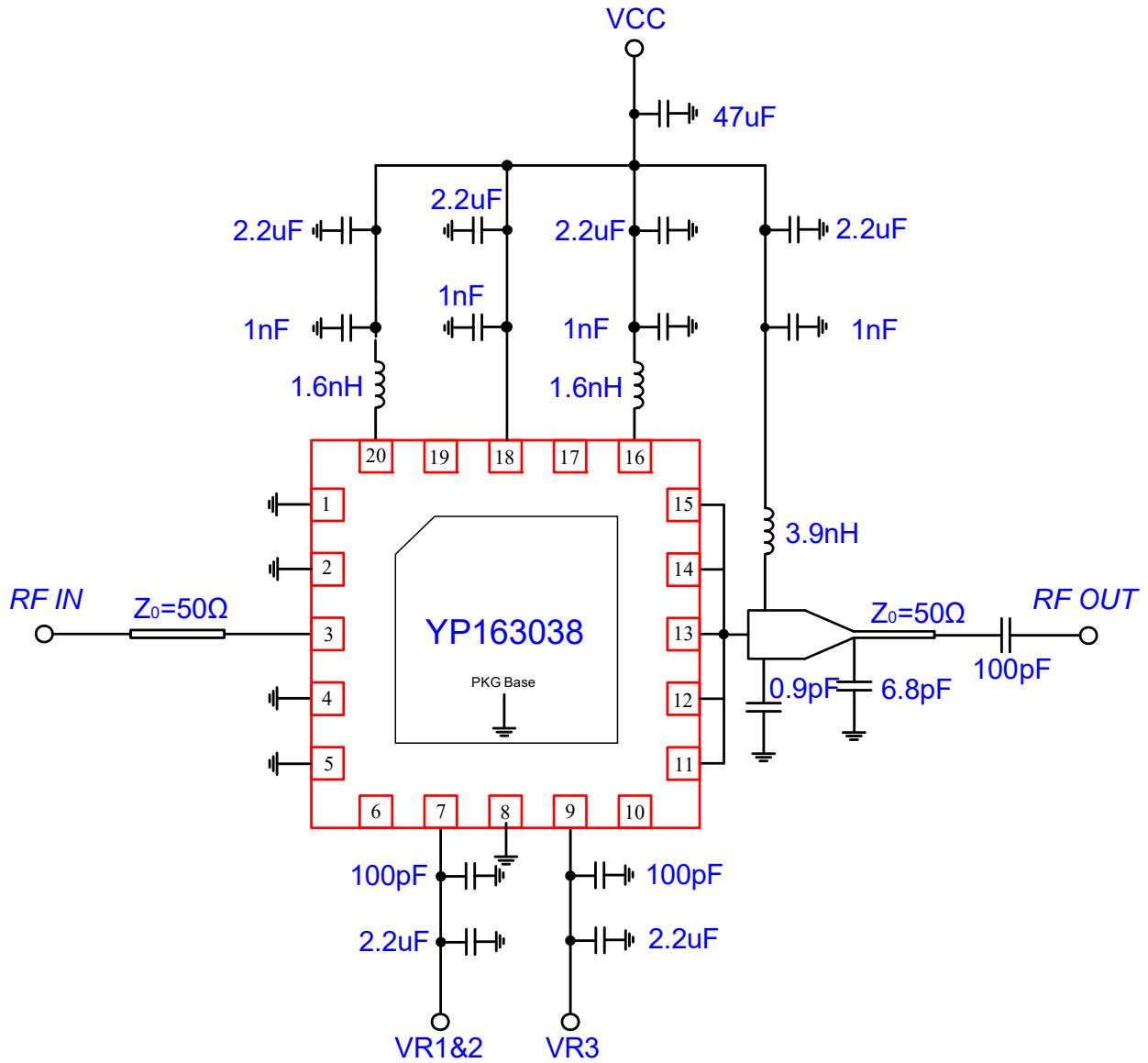

Packaging Diagram

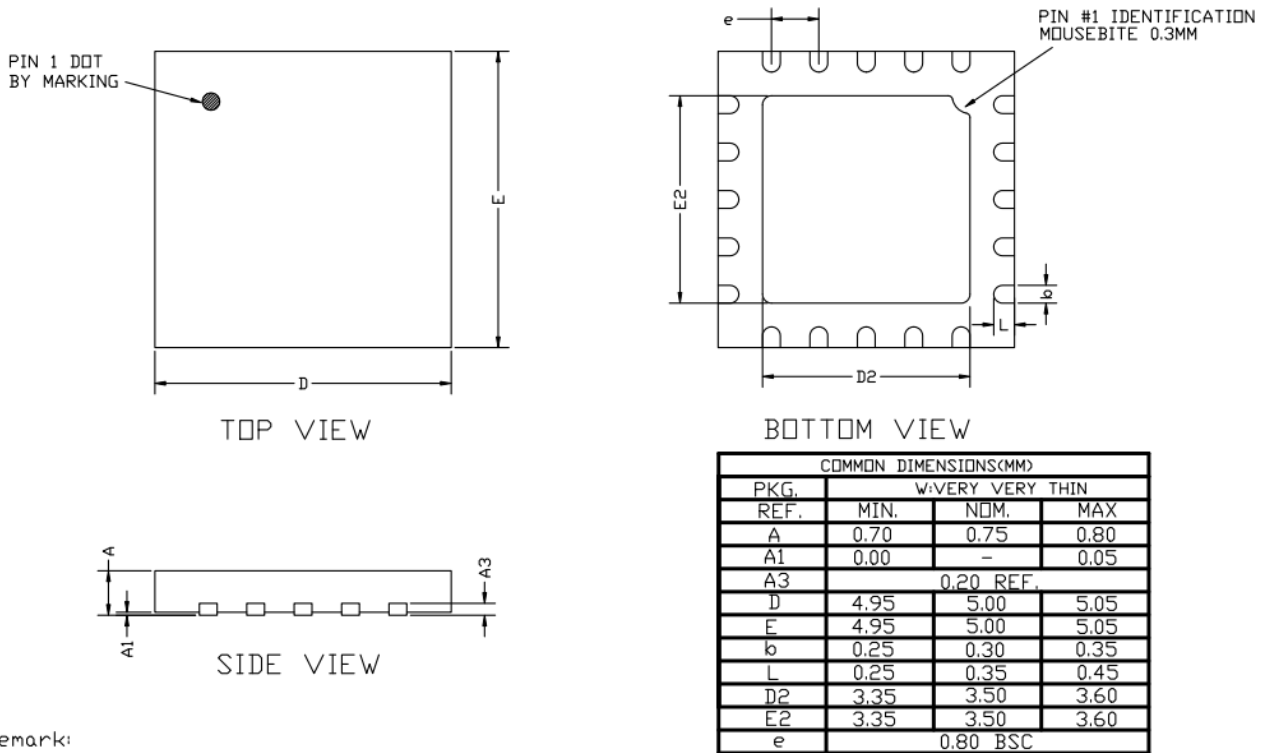

Note 1

Vias(Φ 0.3mm THRU * 25) are required under the backside paddle of this device for proper RF/DC grounding and thermal dissipation. ALL vias are PTH to ground.

Recommended Solder Temperature

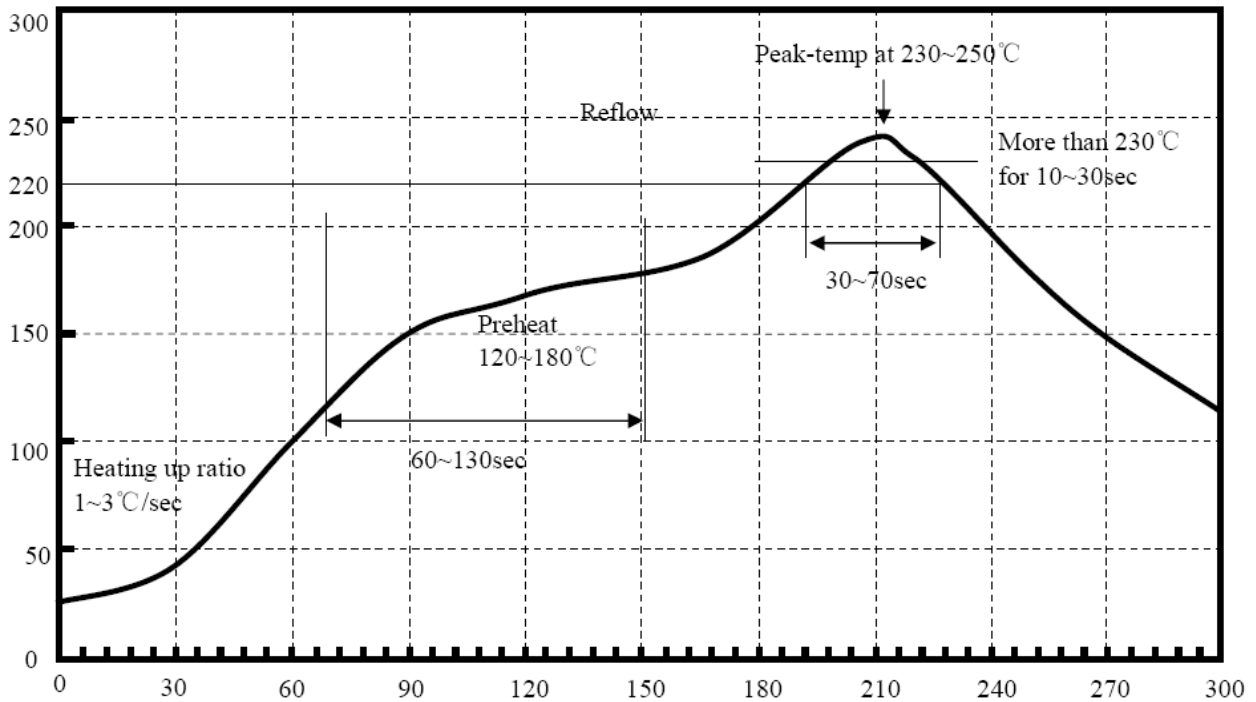

Recommended Temperature

Sn95.5Ag4.0Cu0.5

Note 2

If these amplifiers are to be subjected to solder reflow or high temperature processes, they must be baked for 24 hours at 125°C prior to board mount. Failure to comply may result in crack and/or delamination of critical interfaces within the package.

Tape dimensions and Orientation

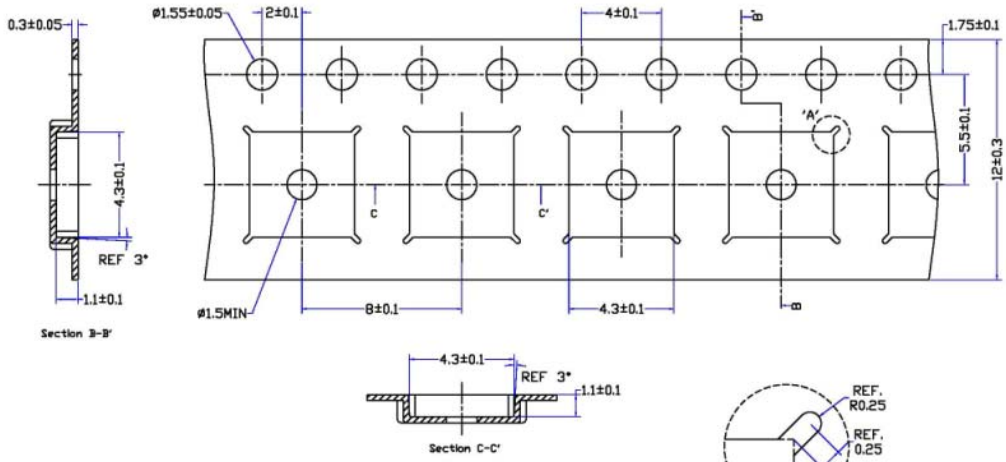

- NOTES:**
- 1.10 pocket hole pitch cumulative tolerance ± 0.2
 2. Carrier camber is within 1mm in 100mm
 3. MATERIAL: CONDUCTIVE POLYSTYRENE
 4. ALL DIMS IN MM
 5. There must not be foreign body adhesion and the state of the surface must be excellent
 6. 17" PAPER-Reel, 51875pockets
 7. Surface resistance 1X10E11(max) OHMS/SQ

Reel dimensions and Orientation

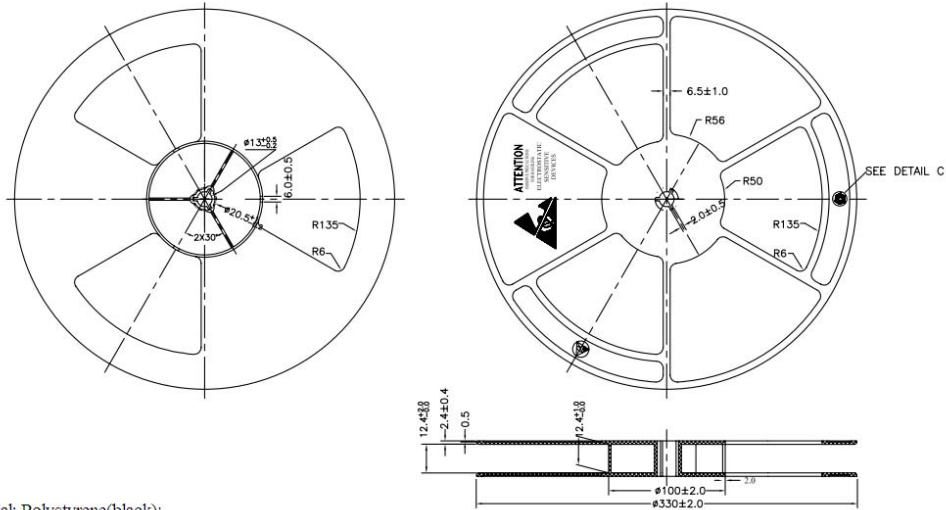

- Notes:**
1. Material: Polystyrene(black);
 2. Surface flatness: Maximum permissible error is 3mm;
 3. Dimensions in millimeters;
 4. Surface resistance: 105 TO 1010/OHMS/SQ;
 5. General tolerances: ± 0.25