IttyBitty RC Timer/Oscillator

Features

- +2.7V to +18V Operation
- Low Current
 - <1 μ A Typical Shutdown Mode (MIC1557)
 - 200 μ A Typical (TRG and THR Low) at 3V Supply
- Timing from Microseconds to Hours
- “Zero” Leakage Trigger and Threshold Inputs
- 50% Square Wave with One Resistor, One Capacitor
- Threshold Input Precedence Over Trigger Input
- <15 Ω Output On-Resistance
- No Output Cross-Conduction Current Spikes
- <0.005%/°C Temperature Stability
- <0.055%/V Supply Stability
- 10-pin Ultra-Thin DFN Package (2 mm \times 2 mm \times 0.4 mm)
- Small SOT-23-5 Surface Mount Package

Applications

- Precision Timer
- Pulse Generation
- Sequential Timing
- Time-Delay Generation
- Missing Pulse Detector
- Micropower Oscillator to 5 MHz
- Charge-Pump Driver
- LED Blinker
- Voltage Converter
- Linear Sweep Generator
- Variable Frequency and Duty Cycle Oscillator

General Description

The MIC1555 IttyBitty CMOS RC timer/oscillator and MIC1557 IttyBitty CMOS RC oscillator are designed to provide rail-to-rail pulses for precise time delay or frequency generation.

These devices are similar in function to the industry standard “555”, without a frequency control (FC) pin or an open-collector discharge (D) pin. The threshold pin (THR) has precedence over the trigger (TRG) input, ensuring that the BiCMOS output is off when TRG is high.

The MIC1555 can be used as an astable (oscillator) or monostable (one-shot) with separate threshold and trigger inputs. In the one-shot mode, the output pulse width is precisely controlled by an external resistor and a capacitor. Time delays may be accurately controlled from microseconds to hours. In the oscillator mode, the output is used to provide precise feedback, with a minimum of one resistor and one capacitor producing a 50% duty cycle square wave.

The MIC1557 is designed for astable (oscillator) operation only, with a chip select/reset (CS) input for low power shut-down. One resistor and one capacitor provide a 50% duty cycle square wave. Other duty cycle ratios may be produced using two diodes and two resistors.

The MIC1555/7 are powered from a +2.7V to +18V supply voltage and are rated for -40°C to $+85^{\circ}\text{C}$ ambient temperature range. The MIC1555/7 are available in SOT-23-5, and thin SOT23-5 5-pin packages. A low profile, ultra-thin UTDFN version of the MIC1555 (with chip select) is also available.

MIC1555/57

Package Types

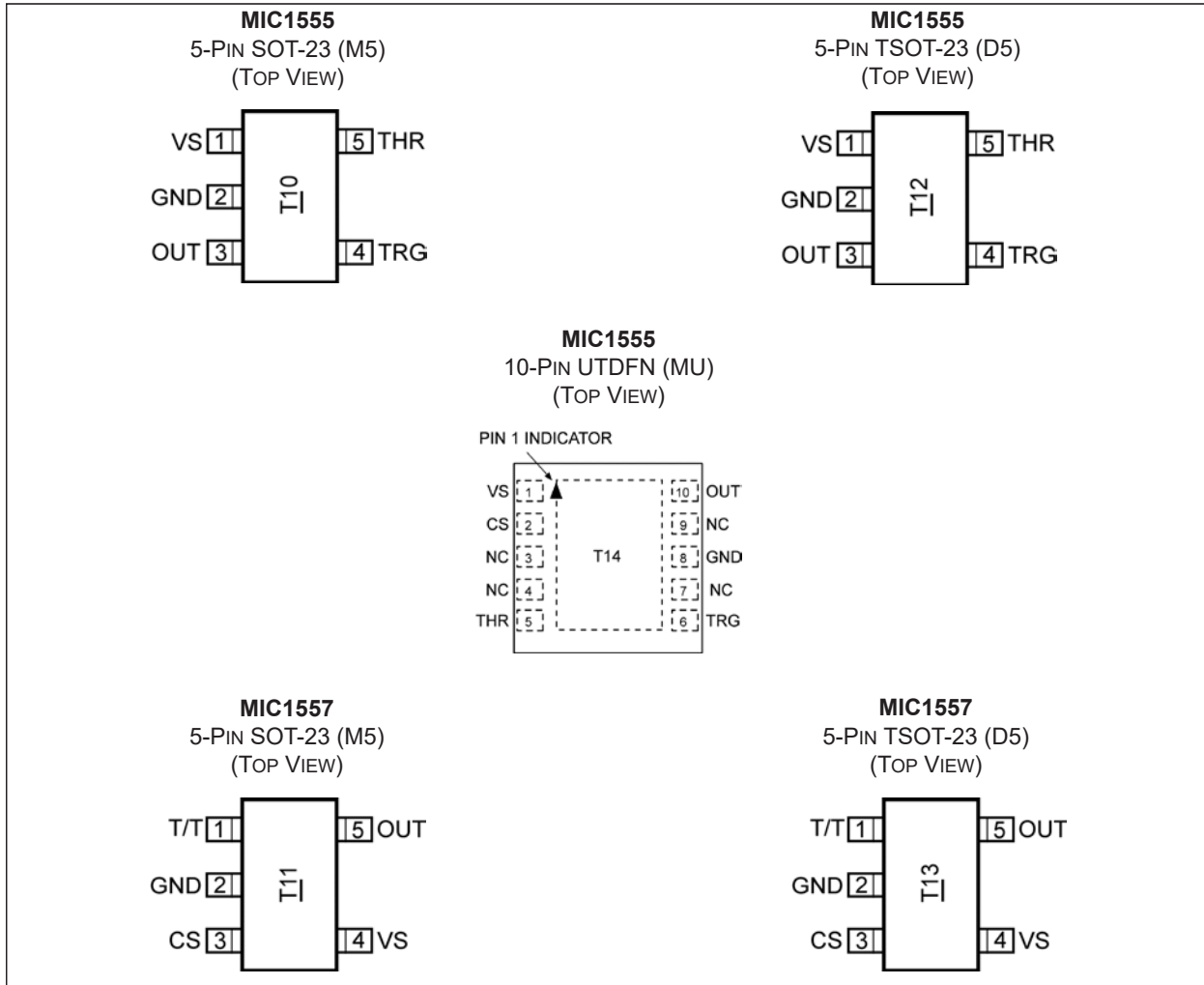

Typical Application Circuits

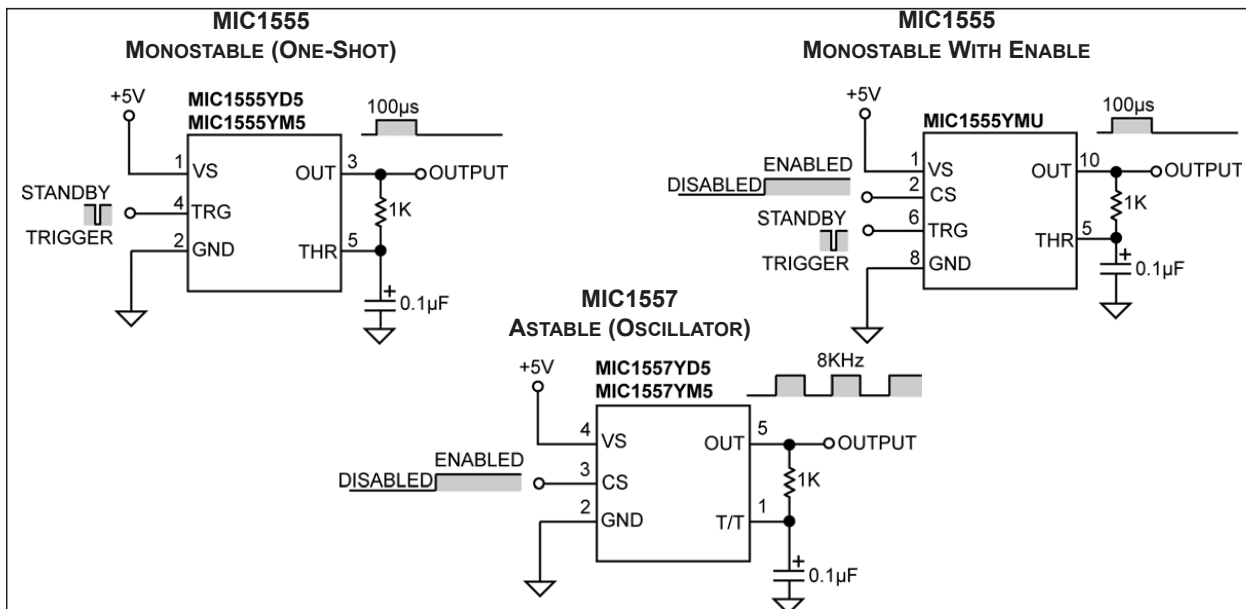

Functional Diagrams

MIC155YM5/MIC155YD5 BLOCK DIAGRAM WITH EXTERNAL COMPONENTS (MONOSTABLE CONFIGURATION)

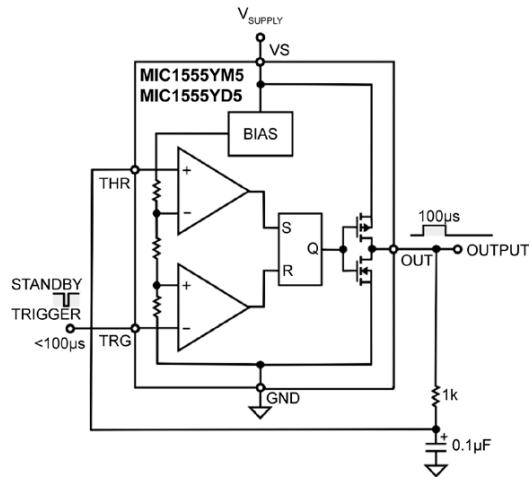

MIC155YMU BLOCK DIAGRAM WITH EXTERNAL COMPONENTS (MONOSTABLE CONFIGURATION)

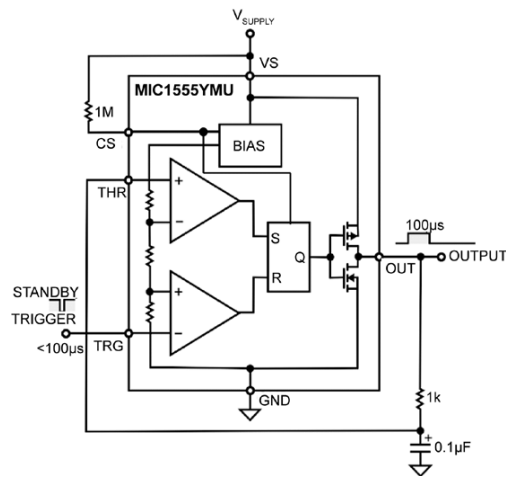

MIC1557YM5/MIC1557YD5 BLOCK DIAGRAM WITH EXTERNAL COMPONENTS (ASTABLE CONFIGURATION)

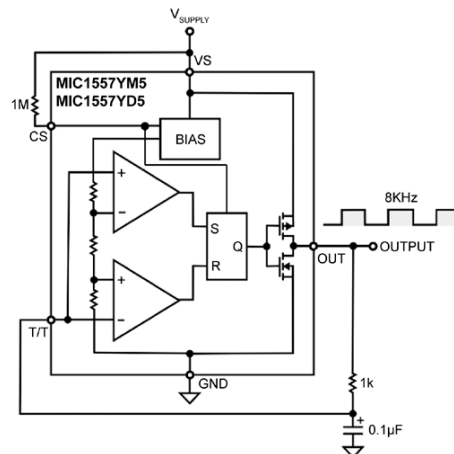

MIC1555/57

1.0 ELECTRICAL CHARACTERISTICS

Absolute Maximum Ratings †

Supply Voltage (V_S).....	+22V
Threshold Voltage (V_{THR} , $V_{T/T}$).....	+22V
Trigger Voltage (V_{TGR} , $V_{T/T}$).....	+22V
ESD HBM Rating (Note 1).....	.2 kV
ESD MM Rating (Note 1).....	200V

Operating Ratings ‡

Supply Voltage (V_S).....	+2.7V to +18V
-------------------------------	---------------

† **Notice:** Stresses above those listed under “Absolute Maximum Ratings” may cause permanent damage to the device. This is a stress rating only and functional operation of the device at those or any other conditions above those indicated in the operational sections of this specification is not intended. Exposure to maximum rating conditions for extended periods may affect device reliability.

‡ **Notice:** The device is not guaranteed to function outside its operating ratings.

Note 1: Devices are ESD protected, however handling precautions recommended.

TABLE 1-1: ELECTRICAL CHARACTERISTICS (Note 1)

Electrical Characteristics: $T_A = +25^\circ\text{C}$, **bold** values indicate $-40^\circ\text{C} \leq T_A \leq +85^\circ\text{C}$, unless noted.

Parameter	Symbol	Min.	Typ.	Max.	Units	Conditions
Supply Current	I_S	—	240	300	μA	MIC1555, $V_S = 5\text{V}$
		—	255	315		MIC1557, $V_S = 5\text{V}$
		—	350	400		MIC1555, $V_S = 15\text{V}$
		—	370	420		MIC1557, $V_S = 15\text{V}$
Monostable Timing Accuracy	—	—	2	—	%	$R_A = 10\text{ k}\Omega$, $C = 0.1\text{ }\mu\text{F}$, $V_S = 5\text{V}$
		858	—	1161		μs
Monostable Drift Over Temperature	—	—	100	—	$\text{ppm}/^\circ\text{C}$	$V_S = 5\text{V}$, $-55^\circ\text{C} \leq T_A \leq +125^\circ\text{C}$ (Note 2)
		—	150	—		$V_S = 10\text{V}$, $-55^\circ\text{C} \leq T_A \leq +125^\circ\text{C}$ (Note 2)
		—	200	—		$V_S = 15\text{V}$, $-55^\circ\text{C} \leq T_A \leq +125^\circ\text{C}$ (Note 2)
Monostable Drift Over Supply	—	—	0.5	—	$\%/V$	$V_S = 5\text{V}$ to 15V (Note 2)
Astable Timing Accuracy	—	—	2	—	%	$R_A = R_B = 10\text{ k}\Omega$, $C = 0.1\text{ }\mu\text{F}$, $V_S = 5\text{V}$
		1717	—	2323		μs
Maximum Astable Frequency	—	—	—	5	MHZ	$R_T = 1\text{ k}\Omega$, $C_T = 47\text{ pF}$, $V_S = 8\text{V}$
Astable Drift Over Temperature	—	—	100	—	$\text{ppm}/^\circ\text{C}$	$V_S = 5\text{V}$, $-55^\circ\text{C} \leq T_A \leq +125^\circ\text{C}$ (Note 2)
		—	150	—		$V_S = 10\text{V}$, $-55^\circ\text{C} \leq T_A \leq +125^\circ\text{C}$ (Note 2)
		—	200	—		$V_S = 15\text{V}$, $-55^\circ\text{C} \leq T_A \leq +125^\circ\text{C}$ (Note 2)
Astable Drift Over Supply	—	—	0.5	—	$\%/V$	$V_S = 5\text{V}$ to 15V (Note 2)
Threshold Voltage	—	61	67	72	$\%/V_S$	$V_S = 15\text{V}$
Trigger Voltage	—	27	32	37	$\%/V_S$	$V_S = 15\text{V}$
Trigger Current	—	—	—	50	nA	$V_S = 15\text{V}$
Threshold Current	—	—	—	50	nA	$V_S = 15\text{V}$
Chip Select	—	50	67	72	$\%/V_S$	On > two-thirds of V_S
		28	33	50		Off < one-third of V_S
Output Voltage Drop	—	—	0.3	1.25	V	$V_S = 15\text{V}$, $I_{\text{SINK}} = 20\text{ mA}$
		—	0.08	0.5		$V_S = 5\text{V}$, $I_{\text{SINK}} = 20\text{ mA}$
		14.1	14.7	—		$V_S = 15\text{V}$, $I_{\text{SOURCE}} = 20\text{ mA}$
		3.8	4.7	—		$V_S = 5\text{V}$, $I_{\text{SOURCE}} = 20\text{ mA}$
Supply Voltage	—	2.7	—	18	V	Functional Operation (Note 2)
Output Rise Time	—	—	15	—	ns	$R_L = 10\text{ M}\Omega$, $C_L = 10\text{ pF}$, $V_S = 5\text{V}$ (Note 2)
Output Fall Time	—	—	15	—	ns	$R_L = 10\text{ M}\Omega$, $C_L = 10\text{ pF}$, $V_S = 5\text{V}$ (Note 2)

Note 1: Specification for packaged product only.

2: Not tested.

MIC1555/57

TEMPERATURE SPECIFICATIONS (Note 1)

Parameters	Sym.	Min.	Typ.	Max.	Units	Conditions
Temperature Ranges						
Ambient Storage Temperature	T_S	-65	—	+150	°C	—
Lead Temperature	—	—	—	+300	°C	Soldering, 10 sec.
Ambient Temperature	T_A	-40	—	+85	°C	—
Package Thermal Resistance						
Thermal Resistance SOT-23-5 and TSOT-23-5	θ_{JA}	—	250	—	°C/W	—
Thermal Resistance 10-Ld UTDFN	θ_{JA}	—	90	—	°C/W	—

Note 1: The maximum allowable power dissipation is a function of ambient temperature, the maximum allowable junction temperature and the thermal resistance from junction to air (i.e., T_A , T_J , θ_{JA}). Exceeding the maximum allowable power dissipation will cause the device operating junction temperature to exceed the maximum +125°C rating. Sustained junction temperatures above +125°C can impact the device reliability.

2.0 TYPICAL PERFORMANCE CURVES

Note: The graphs and tables provided following this note are a statistical summary based on a limited number of samples and are provided for informational purposes only. The performance characteristics listed herein are not tested or guaranteed. In some graphs or tables, the data presented may be outside the specified operating range (e.g., outside specified power supply range) and therefore outside the warranted range.

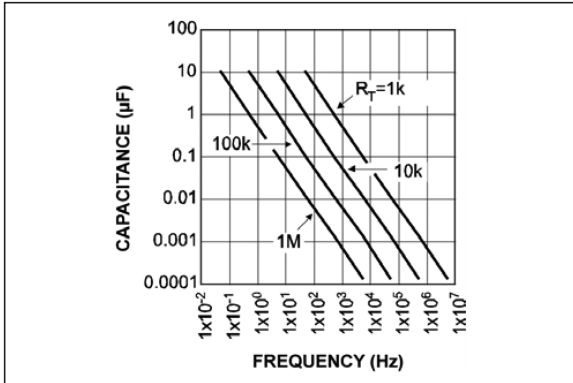

FIGURE 2-1: Astable Frequency.

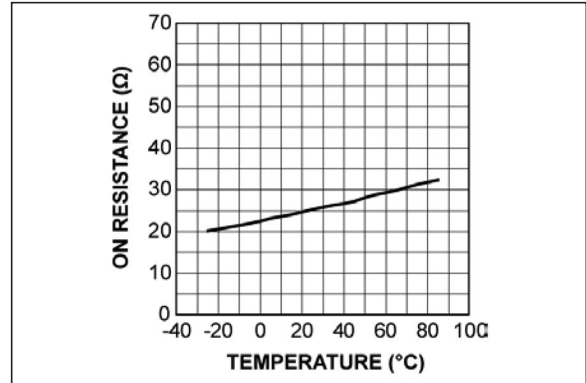

FIGURE 2-4: On Resistance vs. Temperature.

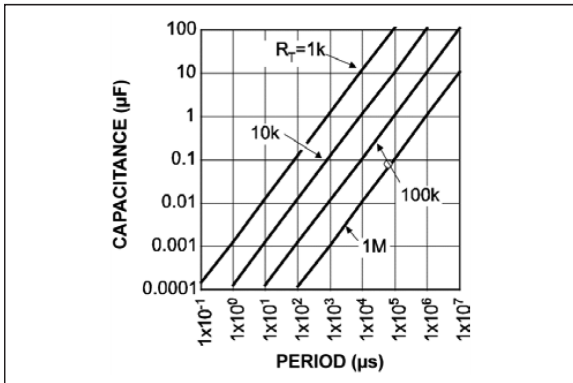

FIGURE 2-2: Pulse Width.

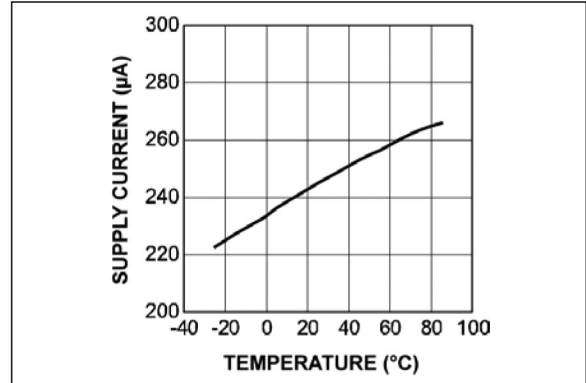

FIGURE 2-5: Supply Current vs. Temperature.

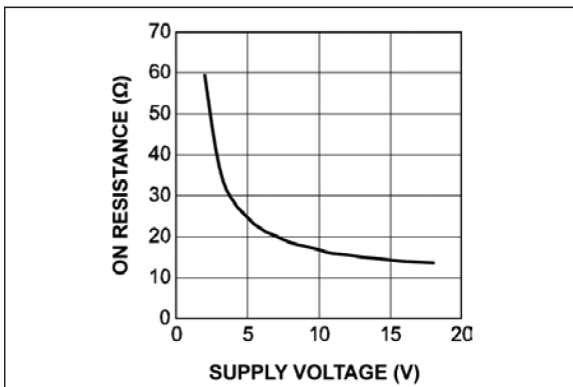

FIGURE 2-3: On Resistance vs. Supply Voltage.

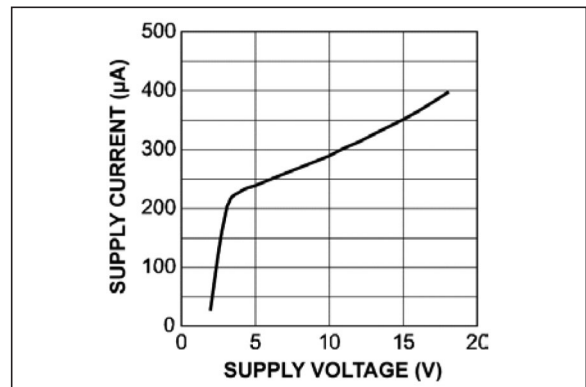

FIGURE 2-6: Supply Current vs. Supply Voltage.

MIC1555/57

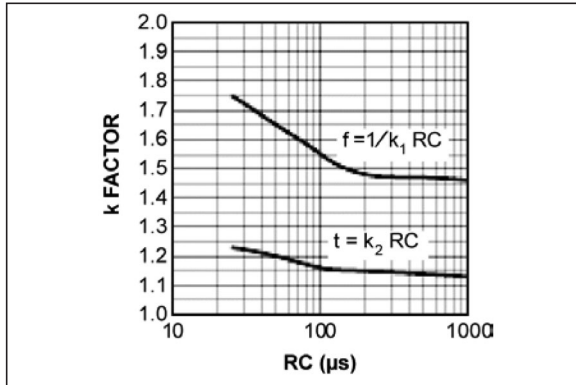

FIGURE 2-7: *k Factors Times RC.*

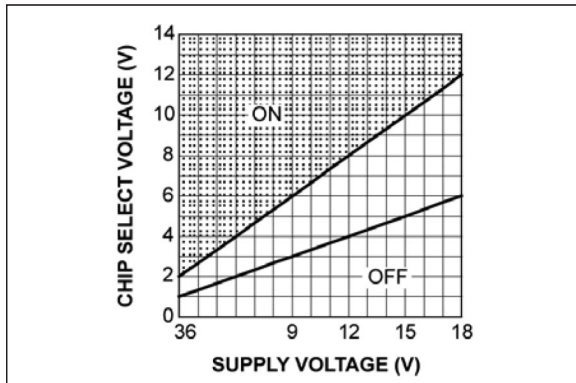

FIGURE 2-8: *MIC1555YMU and MIC1557 Chip Select vs. Supply Voltage.*

3.0 PIN DESCRIPTIONS

The descriptions of the pins are listed in [Table 3-1](#), [Table 3-2](#), and .

TABLE 3-1: PIN FUNCTION TABLE, MIC1555 SOT-23 AND TSOT-23

Pin Number	Pin Name	Description
1	VS	Supply (Input): +2.7V to +18V supply.
2	GND	Ground: Supply return.
3	OUT	Output: CMOS totem-pole output.
4	TRG	Trigger (Input): Sets output high. Active-low (at $\leq 2/3V_S$ nominal).
5	THG	Threshold (Dominant Input): Sets output low. Active-high (at $\geq 2/3V_S$ nominal).

TABLE 3-2: PIN FUNCTION TABLE, MIC1555 UTDFN

Pin Number	Pin Name	Description
1	VS	Supply (Input): +2.7 to +18V supply.
2	CS	Chip Select/Reset (Input): Active-high at $>2/3V_S$. Output off when low at $<1/3V_S$. If chip select functionality is not desired, CS may be connected directly to VS.
3, 4, 7, 9	NC	No Connect. This pin is not internally connected.
5	THR	Threshold (Dominant Input): Sets output low. Active-high (at $\geq 2/3V_S$ nominal).
6	TRG	Trigger (Input): Sets output high. Active-low (at $\leq 2/3V_S$ nominal).
8	GND	Ground. Supply return.
10	OUT	Output: CMOS totem-pole output

TABLE 3-3: PIN FUNCTION TABLE, MIC1557 SOT-23 AND TSOT-23

Pin Number	Pin Name	Description
1	T/T	Trigger/Threshold (Input): Internally connected to both threshold and trigger functions. When the voltage at this pin is $\leq 2/3V_S$, it will set the output high. When the voltage at this pin is $\geq 2/3V_S$, it will set the output low.
2	GND	Ground: Supply return.
3	CS	Chip Select/Reset (Input): Active-high at $>2/3V_S$. Output off when low at $<1/3V_S$. If chip select functionality is not desired, CS may be connected directly to VS.
4	VS	Supply (Input): +2.7 to +18V supply.
5	OUT	Output: CMOS totem-pole output.

MIC1555/57

4.0 FUNCTIONAL DESCRIPTION

The MIC1555/7 provides the logic for creating simple RC timer or oscillator circuits.

The MIC1555 has separate THR (threshold) and TRG (trigger) connections for monostable (one-shot) or astable (oscillator) operation.

The MIC1557 has a single T/T (threshold and trigger) connection for astable (oscillator) operation only. The MIC1557 includes a CS (chip select/reset) control.

For more information, refer to the [Functional Diagrams](#) for MIC1555 and MIC1557.

4.1 Supply

Voltage supply (V_S) is rated for +2.7V to +18V. An external capacitor is recommended to decouple noise.

4.2 Resistive Divider

The resistive voltage divider is constructed of three equal value resistors to produce $1/3V_S$ and $2/3V_S$ voltage for trigger and threshold reference voltages.

4.3 Chip Select/Reset (MIC1555YMU and MIC1557 only)

Chip select/reset (CS) controls the bias supply to the oscillator's internal circuitry. CS must be connected to CMOS logic-high or logic-low levels. Floating CS will result in unpredictable operation. When the chip is deselected, the supply current is less than $1\ \mu\text{A}$. Forcing CS low resets the device by setting the flip flop, forcing the output low. If Chip Select functionality is not desired, CS may be connected directly to V_S .

4.4 Threshold Comparator

The threshold comparator is connected to S (set) on the RS flip-flop. When the threshold voltage ($2/3V_S$) is reached, the flip-flop is set, making the output low. THR is dominant over TRG.

4.5 Trigger Comparator

The trigger comparator is connected to R (reset) on the RS flip-flop. When TRG (trigger) goes below the trigger voltage ($1/3V_S$), the flip-flop resets, making the output high.

4.6 Flip-Flop and Output

A reset signal causes Q to go low, turning on the P-channel MOSFET and turning off the N-channel MOSFET. This makes the output rise to nearly V_S .

A set signal causes Q to go high, turning off the P-channel MOSFET, and turning on the N-channel MOSFET, grounding OUT.

4.7 Basic Monostable Operation

A momentary low signal applied to TRG causes the output to go high. The external capacitor charges slowly through the external resistor. When threshold voltage (V_{THR}) reaches $2/3V_S$, the output is switched off, discharging the capacitor. During power-on, a single pulse may be generated.

For more information, refer to the [Functional Diagrams](#) for MIC1555.

4.8 Basic Astable Operation

The MIC1557 starts with T/T low, causing the output to go high. The external capacitor charges slowly through the external resistor. When $V_{T/T}$ reaches $2/3V_S$ (threshold voltage), the output is switched off, slowly discharging the capacitor. When $V_{T/T}$ decreases to $1/3V_S$ (trigger voltage), the output is switched on, causing $V_{T/T}$ to rise again, repeating the cycle.

For more information, refer to the [Functional Diagrams](#) for MIC1557.

5.0 APPLICATION INFORMATION

5.1 Basic Monostable (One-Shot) Circuit

A monostable oscillator produces a single pulse each time that it is triggered, and is often referred to as a “one-shot.” The pulse width is constant, while the time between pulses depends on the trigger input. One-shots are generally used to stretch incoming pulses of varying widths to a fixed width. The IttyBitty MIC1555 is designed for monostable operation, but may also be connected to provide astable oscillations. The pulse width is determined by the time it takes to charge a capacitor from ground to a comparator trip point. If the capacitor (C_T) is charged through a resistor (R_T) that is connected to the output of an MIC1555, the trip point is approximately $1.1R_T C_T$ (the same time as the initial power-on cycle of an astable circuit.) If the trigger pulse of an MIC1555 remains low longer than the output pulse width, short oscillations may be seen in the output of a one-shot circuit because the threshold pin has precedence over the trigger pin. These occur because the output goes low when the threshold is exceeded, and then goes high again as the trigger function is asserted. AC coupling the input with a series capacitor and a pull-up resistor, with an RC time constant less than the pulse width, will prevent these short oscillations. A diode (D_T) in parallel with (R_T) quickly resets the one-shot.

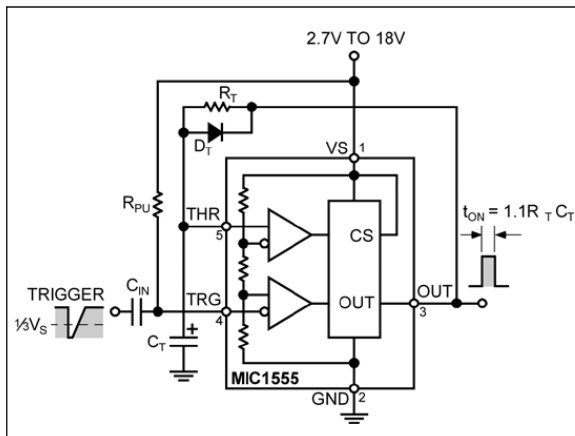

FIGURE 5-1: One-Shot Diagram.

The period of a monostable circuit is:

EQUATION 5-1:

$$t = k_2 RC$$

Where:

- t Period (sec.)
- k_2 Constant (see [Typical Performance Curves](#))
- R Resistance (Ω)
- C Capacitance (F)

5.2 Basic Astable (Oscillator) Circuits

An astable oscillator switches between two states, “on” and “off”, producing a continuous square wave. The MIC1557 is optimized for this function, with the two comparator inputs, threshold and trigger (T/T), tied together internally. CS is brought out to allow on-off control of the oscillator.

The MIC1555 may also be used as an astable oscillator by tying the threshold and trigger pins together, forming a T/T pin. If a resistor (R_T) is connected from the output to a grounded timing capacitor (C_T), the voltage at their junction will ramp up from ground when the output goes high. If the T/T pin is connected to this junction, the output will switch low when the ramp exceeds 2/3 of the input voltage. The junction’s voltage ramps down toward ground while the output is low. When the ramp is below 1/3 of the input voltage, the output switches to high, and the junction ramps up again. The continuing frequency of an MIC1555/7 astable oscillator depends on the RC time constant, and is approximately $0.7/RC$ below 1 MHz. At frequencies above 1 MHz the RC multiplier increases as capacitance is decreased, and propagation delay becomes dominant. Non-symmetrical oscillator operation is possible at frequencies up to 5 MHz.

If a duty cycle other than 50% is desired, a low-power signal diode may be connected in series with the timing resistor (R_A), and a second resistor (R_B) in series with an opposite facing switching diode and resistor connected in parallel (see [Figure 5-2](#)). The frequency is then made up of two components, the charging time (t_A) and the discharging time (t_B) $t_A = 0.7R_A C_T$ and $t_B = 0.7R_B C_T$. The frequency is the reciprocal of the sum of the two times $t_A + t_B$, so the total time is $1.4R_T C_T$. The first half-cycle of an astable, after power-on or CS enable, is lengthened because the capacitor is charging from ground instead of the 1/3 input trigger trip voltage, to $1.1RC$, the same as a monostable pulse.

MIC1555/57

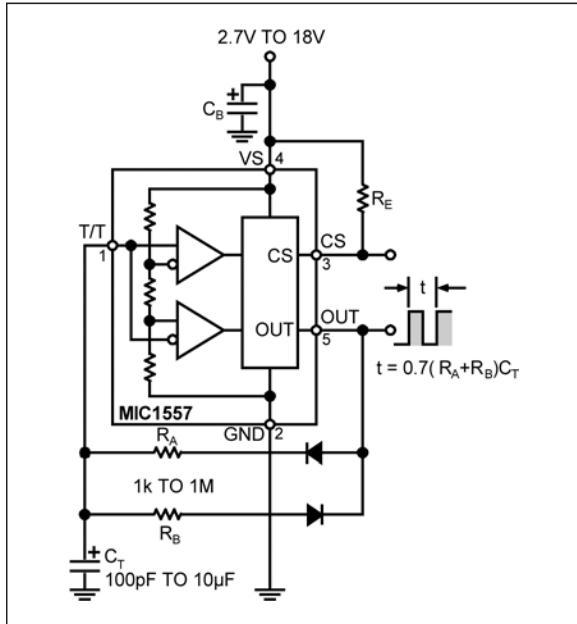

FIGURE 5-2: Oscillator Diagram.

The MIC1555 or MIC1557 can be used to construct an oscillator.

The frequency of an astable oscillator is:

EQUATION 5-2:

$$f = \frac{1}{k_1 RC}$$

Where:

- f Frequency (Hz)
- k_1 Constant (see [Typical Performance Curves](#))
- R Resistance (Ω)
- C Capacitance (F)

To use the MIC1555 as an oscillator, connect TRG to THR.

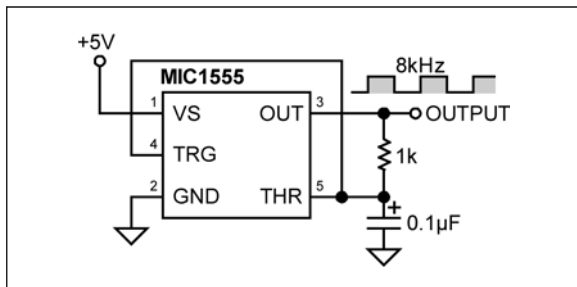

FIGURE 5-3: MIC1555 Oscillator Configuration.

The MIC1555YMU and MIC1557 feature a CS input. With a logic-low signal, CS places the part into a $<1 \mu\text{A}$ shutdown state. If unused, the CS input must be pulled up.

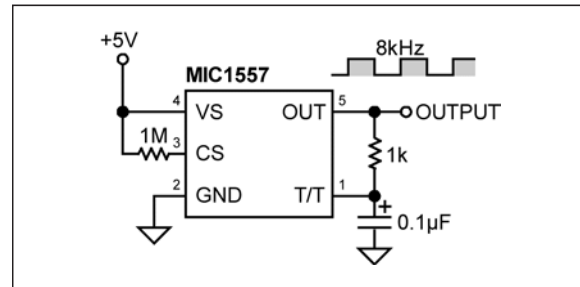

FIGURE 5-4: MIC1557 Oscillator Configuration.

5.3 Falling-Edge Triggered Monostable Circuit

The MIC1555 may be triggered by an AC-coupled falling edge, as shown in [Figure 5-5](#). The RC time constant of the input capacitor and pull-up resistor should be less than the output pulse time, to prevent multiple output pulses. A diode across the timing resistor provides a fast reset at the end of the positive pulse.

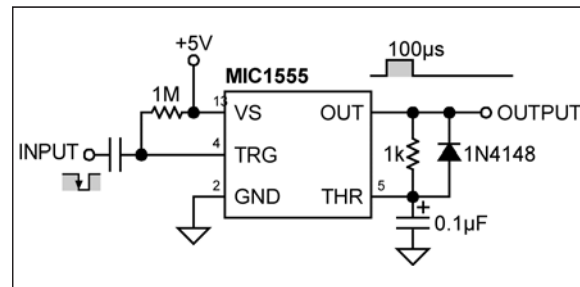

FIGURE 5-5: Falling Edge Trigger Configuration.

5.4 Rising-Edge Triggered Monostable Circuit

The MIC1555 may be triggered by an AC-coupled rising edge, as shown in [Figure 5-6](#). The pulse begins when the AC-coupled input rises, and a diode from the output holds the THR input low until TRG discharges to $1/3V_S$. This circuit provides a low-going output pulse.

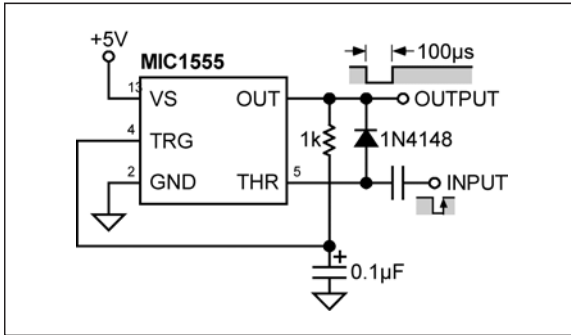

FIGURE 5-6: Rising Edge Trigger Configuration.

5.5 Accuracy

The two comparators in the MIC1555/7 use a resistor voltage divider to set the threshold and trigger trip points to approximately 2/3 and 1/3 of the input voltage, respectively. Because the charge and discharge rates of an RC circuit are dependent on the applied voltage, the timing remains constant if the input voltage varies. If a duty cycle of exactly 50% (or any other value from 1 to 99%), two resistors (or a variable resistor) and two diodes are needed to vary the charge and discharge times. The forward voltage of diodes varies with temperature, so some change in frequency will be seen with temperature extremes, but the duty cycle should track. For absolute timing accuracy, the MIC1555/7 output could be used to control constant current sources to linearly charge and discharge the capacitor, at the expense of added components and board space.

5.6 Long Time Delays

Timing resistors larger than 1 MΩ or capacitors larger than 10 µF are not recommended due to leakage current inaccuracies. Time delays greater than 10 seconds are more accurately produced by dividing the output of an oscillator by a chain of flip-flop counter stages. To produce an accurate one-hour delay, for example, divide a 4.55 Hz MIC1557 oscillator by 16,384 (4000hex, 214) using a CD4020 CMOS divider. 4.5 Hz may be generated with a 1 µF C_T and approximately 156 kΩ.

5.7 Inverting Schmitt Trigger

As shown in Figure 5-7, the trip points of the MIC1555/7 are defined as $1/3V_S$ and $2/3V_S$, which allows either device to be used as a signal conditioning inverter, with hysteresis. A slowly changing input on T/T will be converted to a fast rise or fall-time opposite direction rail-to-rail output voltage. This output may be used to directly drive the gate of a logic-level P-channel MOSFET with a gate pull-up resistor. This is an inverted logic low-side logic level MOSFET driver. A

standard N-channel MOSFET may be driven by a second MIC1555/7, powered by 12V to 15V, to level-shift the input.

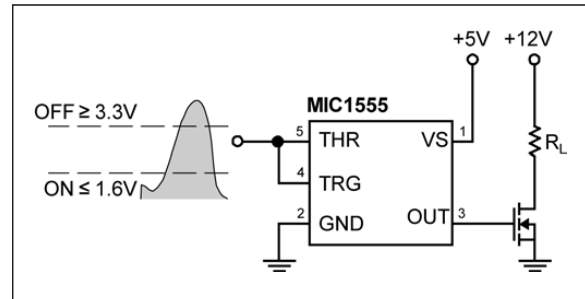

FIGURE 5-7: Schmitt Trigger.

5.8 Charge Pump Low-Side MOSFET Drivers

A standard MOSFET requires approximately >5V to fully enhance the gate for minimum $R_{DS(ON)}$. Substituting a logic-level MOSFET reduces the required gate voltage, allowing an MIC1557 to be used as an inverting Schmitt trigger, described above. An MIC1557 may be configured as a voltage quadrupler to boost a 5V input to over 15V to fully enhance an N-channel MOSFET which may have its drain connected to a higher voltage, through a high-side load. A TTL-high signal applied to CS enables a 10 kHz oscillator, which quickly develops 15V at the gate of the MOSFET, clamped by a Zener diode. A resistor from the gate to ground ensures that the FET will turn off quickly when the MIC1557 is turned off.

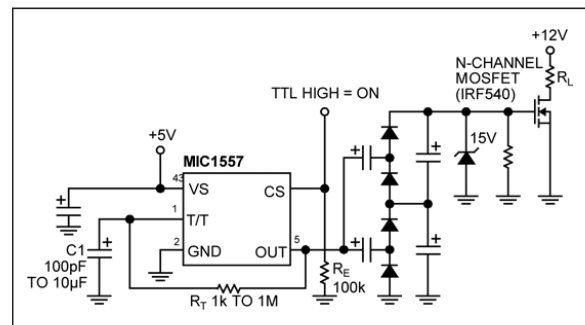

FIGURE 5-8: Charge Pump.

5.9 Audible Voltmeter

If an additional charge or discharge source is connected to the timing capacitor, the frequency may be shifted by turning the source on or off. An MIC1555 oscillator, powered by the circuit under test, may be used to drive a small loud speaker or piezo-electric transducer to provide a medium frequency for an open or high impedance state at the probe. A high tone is generated for a high level, and a lower frequency for a logic low on the probe.

MIC1555/57

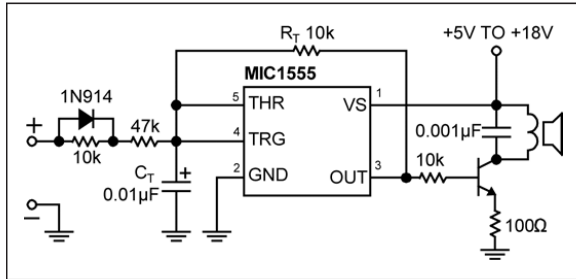
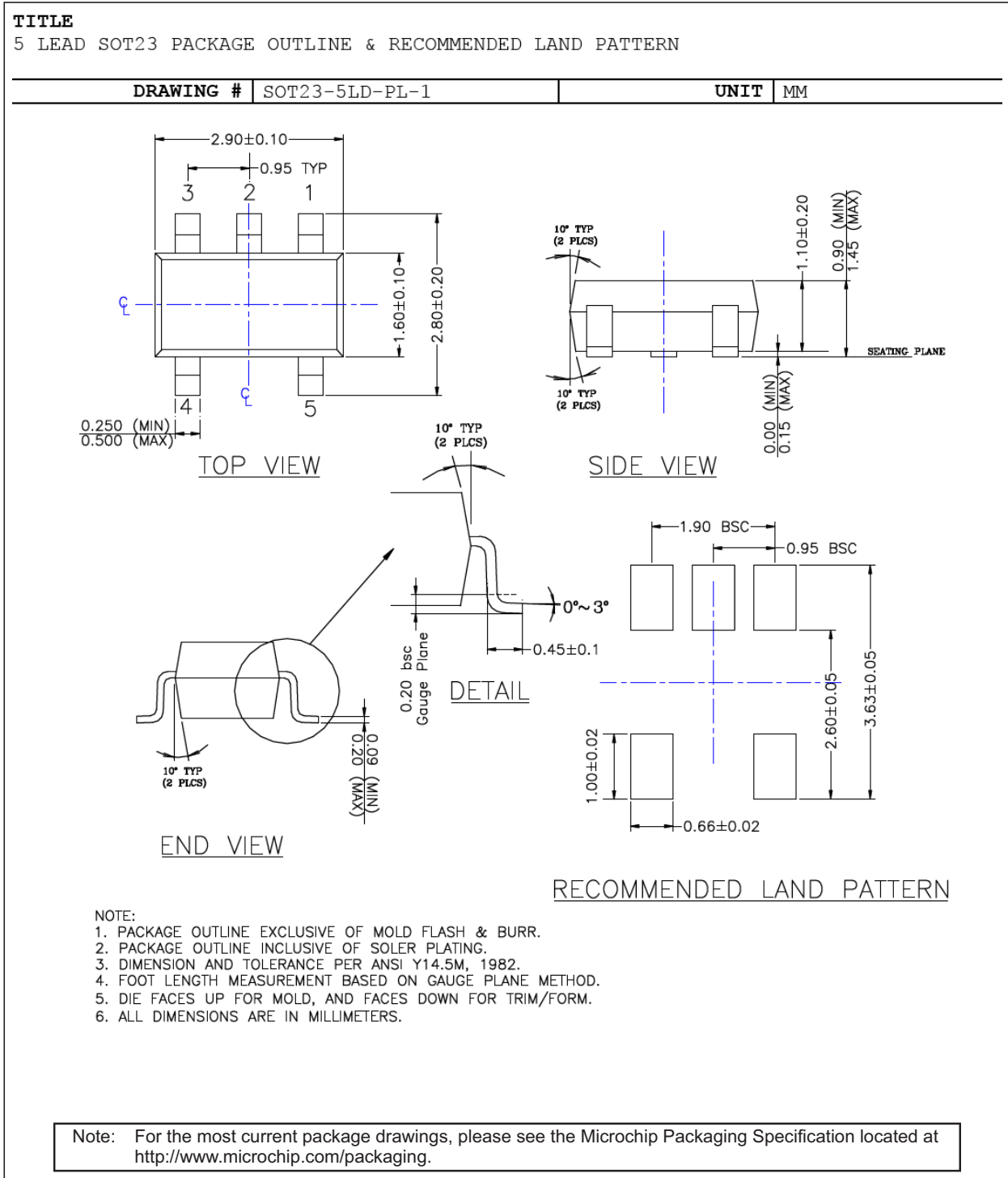

FIGURE 5-9: Audible Voltmeter.

6.0 PACKAGING INFORMATION

5-Lead SOT-23 Package Outline and Recommended Land Pattern



MIC1555/57

5-Lead Thin SOT-23 Package Outline and Recommended Land Pattern

TITLE

5 LEAD TSOT PACKAGE OUTLINE & RECOMMENDED LAND PATTERN

DRAWING #	TSOT-5LD-PL-1	UNIT	MM
------------------	---------------	-------------	----

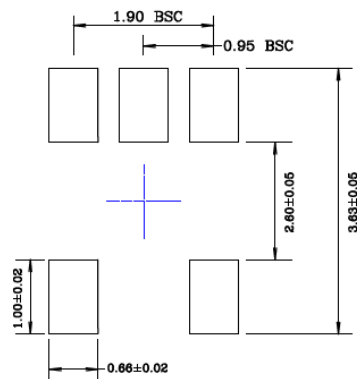
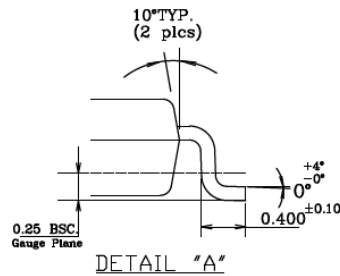
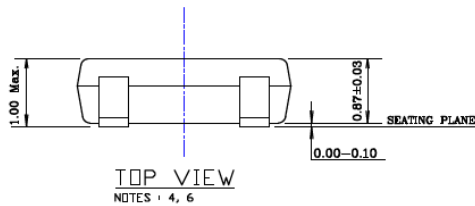
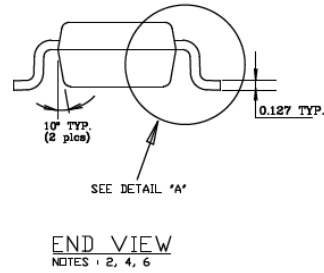
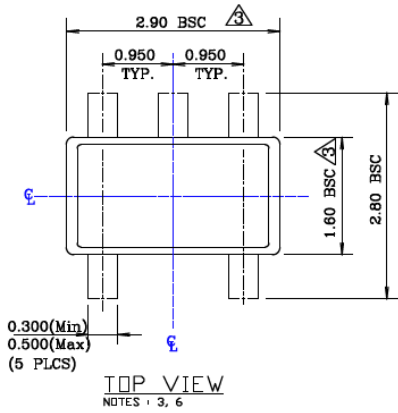

NOTE:

1. Dimensions and tolerances are as per ANSI Y14.5M, 1994.
2. Die is facing up for mold. Die is facing down for trim/form, ie. reverse trim/form.
3. Dimensions are exclusive of mold flash and gate burr.
4. The footlength measuring is based on the gauge plane method.
5. All specification comply to Jedec Spec MO193 Issue C.
6. All dimensions are in millimeters.

Note: For the most current package drawings, please see the Microchip Packaging Specification located at <http://www.microchip.com/packaging>.

10-Lead 2 mm x 2 mm UTDFN Package Outline and Recommended Land Pattern

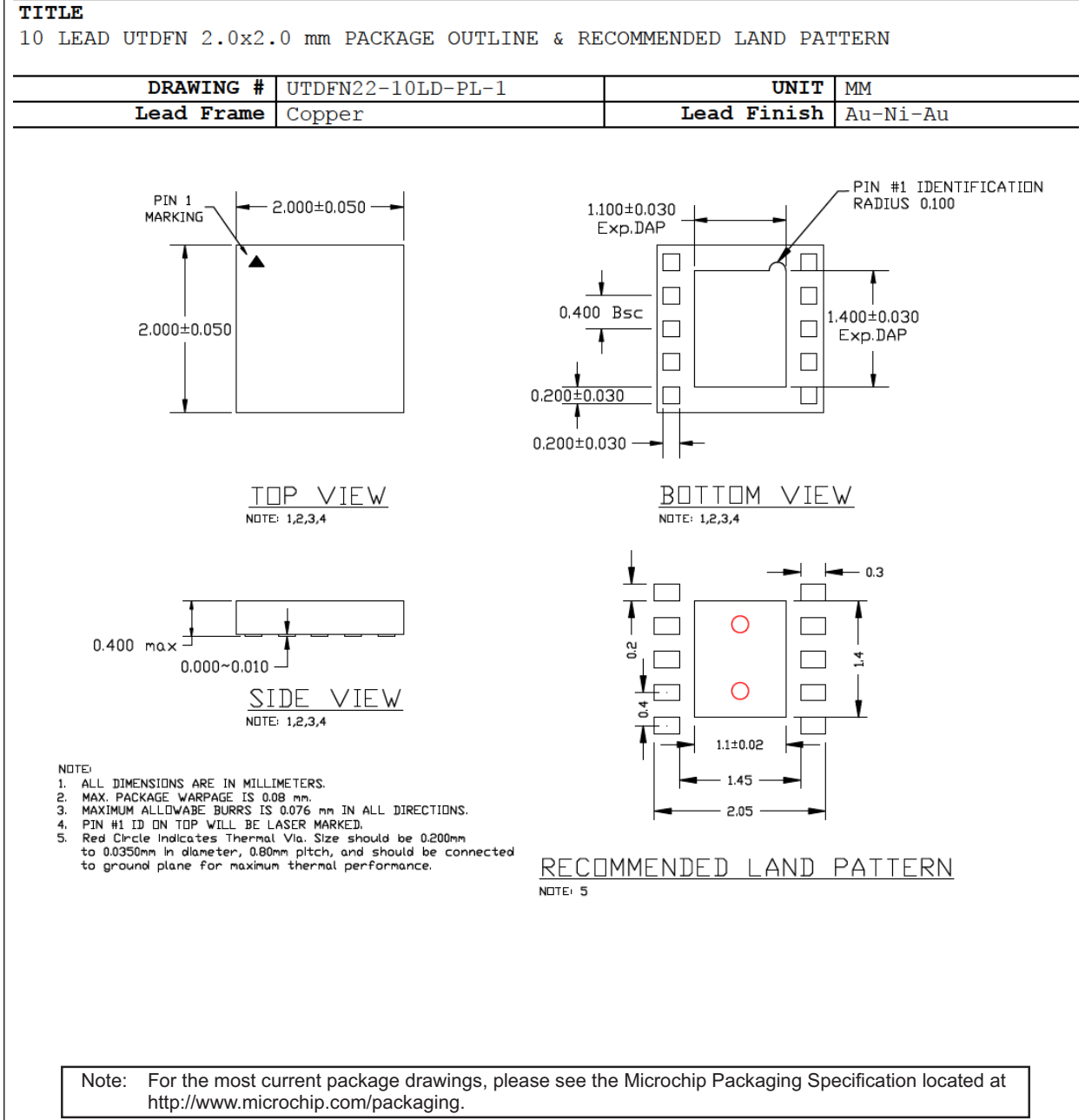

MIC1555/57

NOTES:

APPENDIX A: REVISION HISTORY

Revision A (March 2017)

- Converted Micrel document MIC1555/57 to Microchip data sheet DS20005730A.
- Minor text changes throughout.
- Updated Supply Current values for MIC1557 in **Section 1.0 “Electrical Characteristics”**.

Revision B (April 2019)

- Corrected part number and package type in the [Package Types](#) section.

MIC1555/57

NOTES:

PRODUCT IDENTIFICATION SYSTEM

To order or obtain information, e.g., on pricing or delivery, contact your local Microchip representative or sales office.

<u>PART NO.</u>		X	X	-	XX
Device		Temperature	Package		Media Type
Device:	MIC1555:		IttyBitty RC Timer/Oscillator		
	MIC1557:		IttyBitty RC Timer/Oscillator		
Temperature:	Y	=	-40°C to +85°C		
Package:	M5	=	5-Lead SOT-23		
	D5	=	5-Lead Thin SOT-23		
	MU	=	10-Lead 2 mm x 2 mm UTDFN		
Media Type:	TR	=	3,000/Reel (SOT-23, TSOT-23)		
	TR	=	5,000/Reel (UTDFN)		
	T5	=	500/Reel (UTDFN)		

Examples:	
a) MIC1555YM5-TR:	IttyBitty RC Timer/Oscillator -40°C to +85°C Temp. Range, 5-Lead SOT-23, 3,000/Reel
b) MIC1555YD5-TR:	IttyBitty RC Timer/Oscillator -40°C to +85°C Temp. Range, 5-Lead TSOT-23, 3,000/Reel
c) MIC1555YMU-T5:	IttyBitty RC Timer/Oscillator -40°C to +85°C Temp. Range, 10-Lead UTDFN, 500/Reel
d) MIC1555YMU-TR:	IttyBitty RC Timer/Oscillator -40°C to +85°C Temp. Range, 10-Lead UTDFN, 5,000/Reel
e) MIC1557YM5-TR:	IttyBitty RC Timer/Oscillator -40°C to +85°C Temp. Range, 5-Lead SOT-23, 3,000/Reel
f) MIC1557YD5-TR:	IttyBitty RC Timer/Oscillator -40°C to +85°C Temp. Range, 5-Lead TSOT-23, 3,000/Reel

Note 1: Tape and Reel identifier only appears in the catalog part number description. This identifier is used for ordering purposes and is not printed on the device package. Check with your Microchip Sales Office for package availability with the Tape and Reel option.

MIC1555/57

NOTES:

Note the following details of the code protection feature on Microchip devices:

- Microchip products meet the specification contained in their particular Microchip Data Sheet.
- Microchip believes that its family of products is one of the most secure families of its kind on the market today, when used in the intended manner and under normal conditions.
- There are dishonest and possibly illegal methods used to breach the code protection feature. All of these methods, to our knowledge, require using the Microchip products in a manner outside the operating specifications contained in Microchip's Data Sheets. Most likely, the person doing so is engaged in theft of intellectual property.
- Microchip is willing to work with the customer who is concerned about the integrity of their code.
- Neither Microchip nor any other semiconductor manufacturer can guarantee the security of their code. Code protection does not mean that we are guaranteeing the product as “unbreakable.”

Code protection is constantly evolving. We at Microchip are committed to continuously improving the code protection features of our products. Attempts to break Microchip's code protection feature may be a violation of the Digital Millennium Copyright Act. If such acts allow unauthorized access to your software or other copyrighted work, you may have a right to sue for relief under that Act.

Information contained in this publication regarding device applications and the like is provided only for your convenience and may be superseded by updates. It is your responsibility to ensure that your application meets with your specifications. MICROCHIP MAKES NO REPRESENTATIONS OR WARRANTIES OF ANY KIND WHETHER EXPRESS OR IMPLIED, WRITTEN OR ORAL, STATUTORY OR OTHERWISE, RELATED TO THE INFORMATION, INCLUDING BUT NOT LIMITED TO ITS CONDITION, QUALITY, PERFORMANCE, MERCHANTABILITY OR FITNESS FOR PURPOSE. Microchip disclaims all liability arising from this information and its use. Use of Microchip devices in life support and/or safety applications is entirely at the buyer's risk, and the buyer agrees to defend, indemnify and hold harmless Microchip from any and all damages, claims, suits, or expenses resulting from such use. No licenses are conveyed, implicitly or otherwise, under any Microchip intellectual property rights unless otherwise stated.

Microchip received ISO/TS-16949:2009 certification for its worldwide headquarters, design and wafer fabrication facilities in Chandler and Tempe, Arizona; Gresham, Oregon and design centers in California and India. The Company's quality system processes and procedures are for its PIC® MCUs and dsPIC® DSCs, KEELoq® code hopping devices, Serial EEPROMs, microperipherals, nonvolatile memory and analog products. In addition, Microchip's quality system for the design and manufacture of development systems is ISO 9001:2000 certified.

**QUALITY MANAGEMENT SYSTEM
CERTIFIED BY DNV
= ISO/TS 16949 =**

Trademarks

The Microchip name and logo, the Microchip logo, AnyRate, AVR, AVR logo, AVR Freaks, BitCloud, chipKIT, chipKIT logo, CryptoMemory, CryptoRF, dsPIC, FlashFlex, flexPWR, Helder, JukeBlox, KeeLoq, Klear, LANCheck, LINK MD, maXStylus, maXTouch, MediaLB, megaAVR, MOST, MOST logo, MPLAB, OptoLyzer, PIC, picoPower, PICSTART, PIC32 logo, Prochip Designer, QTouch, SAM-BA, SpyNIC, SST, SST Logo, SuperFlash, tinyAVR, UNI/O, and XMEGA are registered trademarks of Microchip Technology Incorporated in the U.S.A. and other countries.

ClockWorks, The Embedded Control Solutions Company, EtherSynch, Hyper Speed Control, HyperLight Load, IntellIMOS, mTouch, Precision Edge, and Quiet-Wire are registered trademarks of Microchip Technology Incorporated in the U.S.A.

Adjacent Key Suppression, AKS, Analog-for-the-Digital Age, Any Capacitor, AnyIn, AnyOut, BodyCom, CodeGuard, CryptoAuthentication, CryptoAutomotive, CryptoCompanion, CryptoController, dsPICDEM, dsPICDEM.net, Dynamic Average Matching, DAM, ECAN, EtherGREEN, In-Circuit Serial Programming, ICSP, INICnet, Inter-Chip Connectivity, JitterBlocker, KlearNet, KlearNet logo, memBrain, Mindi, MiWi, motorBench, MPASM, MPF, MPLAB Certified logo, MPLIB, MPLINK, MultiTRAK, NetDetach, Omniscient Code Generation, PICDEM, PICDEM.net, PICKit, PICtail, PowerSmart, PureSilicon, QMatrix, REAL ICE, Ripple Blocker, SAM-ICE, Serial Quad I/O, SMART-I.S., SQI, SuperSwitcher, SuperSwitcher II, Total Endurance, TSHARC, USBCheck, VariSense, ViewSpan, WiperLock, Wireless DNA, and ZENA are trademarks of Microchip Technology Incorporated in the U.S.A. and other countries.

SQTP is a service mark of Microchip Technology Incorporated in the U.S.A.

Silicon Storage Technology is a registered trademark of Microchip Technology Inc. in other countries.

GestIC is a registered trademark of Microchip Technology Germany II GmbH & Co. KG, a subsidiary of Microchip Technology Inc., in other countries.

All other trademarks mentioned herein are property of their respective companies.

© 2017-2019, Microchip Technology Incorporated, All Rights Reserved.

ISBN: 978-1-5224-4376-6



MICROCHIP

Worldwide Sales and Service

AMERICAS

Corporate Office
2355 West Chandler Blvd.
Chandler, AZ 85224-6199
Tel: 480-792-7200
Fax: 480-792-7277
Technical Support:
<http://www.microchip.com/support>
Web Address:
www.microchip.com

Atlanta

Duluth, GA
Tel: 678-957-9614
Fax: 678-957-1455

Austin, TX

Tel: 512-257-3370

Boston

Westborough, MA
Tel: 774-760-0087
Fax: 774-760-0088

Chicago

Itasca, IL
Tel: 630-285-0071
Fax: 630-285-0075

Dallas

Addison, TX
Tel: 972-818-7423
Fax: 972-818-2924

Detroit

Novi, MI
Tel: 248-848-4000

Houston, TX

Tel: 281-894-5983

Indianapolis

Noblesville, IN
Tel: 317-773-8323
Fax: 317-773-5453
Tel: 317-536-2380

Los Angeles

Mission Viejo, CA
Tel: 949-462-9523
Fax: 949-462-9608
Tel: 951-273-7800

Raleigh, NC

Tel: 919-844-7510

New York, NY

Tel: 631-435-6000

San Jose, CA

Tel: 408-735-9110
Tel: 408-436-4270

Canada - Toronto

Tel: 905-695-1980
Fax: 905-695-2078

ASIA/PACIFIC

Australia - Sydney
Tel: 61-2-9868-6733

China - Beijing
Tel: 86-10-8569-7000

China - Chengdu
Tel: 86-28-8665-5511

China - Chongqing
Tel: 86-23-8980-9588

China - Dongguan
Tel: 86-769-8702-9880

China - Guangzhou
Tel: 86-20-8755-8029

China - Hangzhou
Tel: 86-571-8792-8115

China - Hong Kong SAR
Tel: 852-2943-5100

China - Nanjing
Tel: 86-25-8473-2460

China - Qingdao
Tel: 86-532-8502-7355

China - Shanghai
Tel: 86-21-3326-8000

China - Shenyang
Tel: 86-24-2334-2829

China - Shenzhen
Tel: 86-755-8864-2200

China - Suzhou
Tel: 86-186-6233-1526

China - Wuhan
Tel: 86-27-5980-5300

China - Xian
Tel: 86-29-8833-7252

China - Xiamen
Tel: 86-592-2388138

China - Zhuhai
Tel: 86-756-3210040

ASIA/PACIFIC

India - Bangalore
Tel: 91-80-3090-4444

India - New Delhi
Tel: 91-11-4160-8631

India - Pune
Tel: 91-20-4121-0141

Japan - Osaka
Tel: 81-6-6152-7160

Japan - Tokyo
Tel: 81-3-6880-3770

Korea - Daegu
Tel: 82-53-744-4301

Korea - Seoul
Tel: 82-2-554-7200

Malaysia - Kuala Lumpur
Tel: 60-3-7651-7906

Malaysia - Penang
Tel: 60-4-227-8870

Philippines - Manila
Tel: 63-2-634-9065

Singapore
Tel: 65-6334-8870

Taiwan - Hsin Chu
Tel: 886-3-577-8366

Taiwan - Kaohsiung
Tel: 886-7-213-7830

Taiwan - Taipei
Tel: 886-2-2508-8600

Thailand - Bangkok
Tel: 66-2-694-1351

Vietnam - Ho Chi Minh
Tel: 84-28-5448-2100

EUROPE

Austria - Wels
Tel: 43-7242-2244-39
Fax: 43-7242-2244-393

Denmark - Copenhagen
Tel: 45-4450-2828
Fax: 45-4485-2829

Finland - Espoo
Tel: 358-9-4520-820

France - Paris
Tel: 33-1-69-53-63-20
Fax: 33-1-69-30-90-79

Germany - Garching
Tel: 49-8931-9700

Germany - Haan
Tel: 49-2129-3766400

Germany - Heilbronn
Tel: 49-7131-67-3636

Germany - Karlsruhe
Tel: 49-721-625370

Germany - Munich
Tel: 49-89-627-144-0
Fax: 49-89-627-144-44

Germany - Rosenheim
Tel: 49-8031-354-560

Israel - Ra'anana
Tel: 972-9-744-7705

Italy - Milan
Tel: 39-0331-742611
Fax: 39-0331-466781

Italy - Padova
Tel: 39-049-7625286

Netherlands - Drunen
Tel: 31-416-690399
Fax: 31-416-690340

Norway - Trondheim
Tel: 47-7288-4388

Poland - Warsaw
Tel: 48-22-3325737

Romania - Bucharest
Tel: 40-21-407-87-50

Spain - Madrid
Tel: 34-91-708-08-90
Fax: 34-91-708-08-91

Sweden - Gothenberg
Tel: 46-31-704-60-40

Sweden - Stockholm
Tel: 46-8-5090-4654

UK - Wokingham
Tel: 44-118-921-5800
Fax: 44-118-921-5820

Mouser Electronics

Authorized Distributor

Click to View Pricing, Inventory, Delivery & Lifecycle Information:

Microchip:

[MIC1557YM5 TR](#) [MIC1555YM5 TR](#) [MIC1555YMU TR](#) [MIC1555YMU T5](#) [MIC1555YD5 TR](#) [MIC1557YD5 TR](#)
[MIC1555YM5-TR](#) [MIC1557YM5-TR](#) [MIC1555YMU-T5](#) [MIC1555YD5-TR](#) [MIC1555YMU-TR](#) [MIC1557YD5-TR](#)